

How to Implement ICSP™ Using PIC12C5XX OTP MCUs

Author: Thomas Schmidt
Microchip Technology Inc.

INTRODUCTION

The technical brief describes how to implement in-circuit serial programming (ICSP™) using the PIC12C5XX OTP PICmicro™ MCU.

ICSP is a simple way to manufacture your board with an unprogrammed PICmicro and program the device just before shipping the product. Programming the PIC12C5XX MCU in-circuit has many advantages for developing and manufacturing your product.

- **Reduces inventory of products with old firmware.** With ICSP, the user can manufacture product without programming the PICmicro MCU. The PICmicro will be programmed just before the product is shipped.
- **ICSP in production.** New software revisions or additional software modules can be programmed during production into the PIC12C5XX MCU.
- **ICSP in the field.** Even after your product has been sold, a service man can update your program with new program modules.
- **One hardware with different software.** ICSP allows the user to have one hardware, whereas the PIC12C5XX MCU can be programmed with different types of software.
- **Last minute programming.** Last minute programming can also facilitate quick turnarounds on

custom orders for your products.

IN-CIRCUIT SERIAL PROGRAMMING

To implement ICSP into an application, the user needs to consider three main components of an ICSP system: Application Circuit, Programmer and Programming Environment.

Application Circuit

During the initial design phase of the application circuit, certain considerations have to be taken into account. Figure 1 shows a typical circuit that addresses the details to be considered during design. In order to implement ICSP on your application board you have to put the following issues into consideration:

1. Isolation of the GP3/MCLR/VPP pin from the rest of the circuit.
2. Isolation of pins GP1 and GP0 from the rest of the circuit.
3. Capacitance on each of the VDD, GP3/MCLR/VPP, GP1, and GP0 pins.
4. Interface to the programmer.
5. Minimum and maximum operating voltage for VDD.

FIGURE 1: TYPICAL APPLICATION CIRCUIT

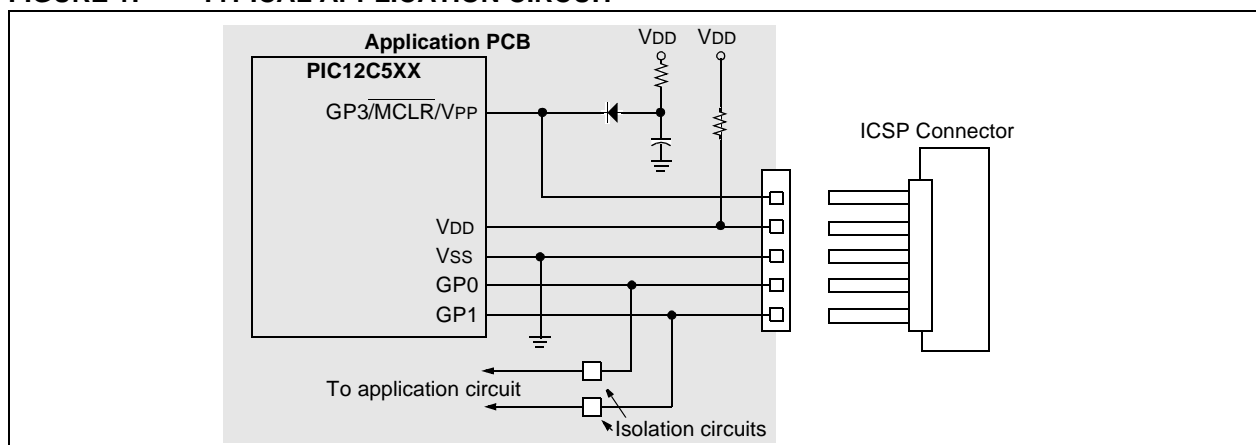

PRO MATE and PICSTART are registered trademarks and PICmicro and ICSP are trademarks of Microchip Technology Inc.

Isolation of the GP3/MCLR/VPP Pin from the Rest of the Circuit

PIC12C5XX devices have two ways of configuring the MCLR pin:

- MCLR can be connected either to an external RC circuit or
- MCLR is tied internally to VDD

When GP3/MCLR/VPP pin is connected to an external RC circuit, the pull-up resistor is tied to VDD, and a capacitor is tied to ground. This circuit can affect the operation of ICSP depending on the size of the capacitor.

Another point of consideration with the GP3/MCLR/VPP pin, is that when the PICmicro is programmed, this pin is driven up to 13V and also to ground. Therefore, the application circuit must be isolated from the voltage coming from the programmer.

When MCLR is tied internally to VDD, the user has only to consider that up to 13V are present during programming of the GP3/MCLR/VPP pin. This might affect other components connected to that pin.

For more information about configuring the GP3/MCLR/VPP internally to VDD, please refer to the PIC12C5XX data sheet (DS40139).

Isolation of Pins GP1 and GP0 from the Rest of the Circuit

Pins GP1 and GP0 are used by the PICmicro for serial programming. GP1 is the clock line and GP0 is the data line.

GP1 is driven by the programmer. GP0 is a bi-directional pin that is driven by the programmer when programming and driven by the PICmicro when verifying. These pins must be isolated from the rest of the application circuit so as not to affect the signals during programming. You must take into consideration the output impedance of the programmer when isolating GP1 and GP0 from the rest of the circuit. This isolation circuit must account for GP1 being an input on the PICmicro and for GP0 being bi-directional pin.

For example, PRO MATE[®] II has an output impedance of 1 k Ω . If the design permits, these pins should not be used by the application. This is not the case with most designs. As a designer, you must consider what type of circuitry is connected to GP1 and GP0 and then make a decision on how to isolate these pins.

Total Capacitance on VDD, GP3/MCLR/VPP, GP1, and GP0

The total capacitance on the programming pins affects the rise rates of these signals as they are driven out of the programmer. Typical circuits use several hundred microfarads of capacitance on VDD, which helps to dampen noise and improve electromagnetic interference. However, this capacitance requires a fairly strong driver in the programmer to meet the rise rate timings for VDD.

Interface to the Programmer

Most programmers are designed to simply program the PICmicro itself and don't have strong enough drivers to power the application circuit.

One solution is to use a driver board between the programmer and the application circuit. The driver board needs a separate power supply that is capable of driving the VPP, VDD, GP1, and GP0 pins with the correct ramp rates and also should provide enough current to power-up the application circuit.

The cable length between the programmer and the circuit is also an important factor for ICSP. If the cable between the programmer and the circuit is too long, signal reflections may occur. These reflections can momentarily cause up to twice the voltage at the end of the cable, that was sent from the programmer. This voltage can cause a latch-up. In this case, a termination resistor has to be used at the end of the signal line.

Minimum and Maximum Operating Voltage for VDD

The PIC12C5XX programming specification states that the device should be programmed at 5V. Special considerations must be made if your application circuit operates at 3V only. These considerations may include totally isolating the PICmicro during programming. The other point of consideration is that the device must be verified at minimum and maximum operation voltage of the circuit in order to ensure proper programming margin.

For example, a battery driven system may operate from three 1.5V cells giving an operating voltage range of 2.7V to 4.5V. The programmer must program the device at 5V and must verify the program memory contents at both 2.7V and 4.5V to ensure that proper programming margins have been achieved.

THE PROGRAMMER

PIC12C5XX MCUs only use serial programming and, therefore, all programmers supporting these devices will support the ICSP. One issue with the programmer is the drive capability. As discussed before, it must be able to provide the specified rise rates on the ICSP signals and also provide enough current to power the application circuit. It is recommended that you buffer the programming signals.

Another point of consideration for the programmer is what VDD levels are used to verify the memory contents of the PICmicro. For instance, the PRO MATE II verifies program memory at the minimum and maximum VDD levels for the specified device and is therefore considered a production quality programmer. On the other hand, the PICSTART® Plus only verifies at 5V and is for prototyping use only. The PIC12C5XX programming specifications state that the program memory contents should be verified at both the minimum and maximum VDD levels that the application circuit will be operating. This implies that the application circuit must be able to handle the varying VDD voltages.

There are also several third-party programmers that are available. You should select a programmer based on the features it has and how it fits into your programming environment. The *Microchip Development Systems Ordering Guide* (DS30177) provides detailed information on all our development tools. The *Microchip Third Party Guide* (DS00104) provides information on all of our third party development tool developers. Please consult these two references when selecting a programmer. Many options exist including serial or parallel PC host connection, stand-alone operation, and single or gang programmers.

PROGRAMMING ENVIRONMENT

The programming environment will affect the type of programmer used, the programmer cable length, and the application circuit interface. Some programmers are well suited for a manual assembly line while others are desirable for an automated assembly line. A gang programmer should be chosen for programming multiple MCUs at one time. The physical distance between the programmer and the application circuit affects the load capacitance on each of the programming signals. This will directly affect the drive strength needed to provide the correct signal rise rates and current. Finally, the application circuit interface to the programmer depends on the size constraints of the application circuit itself and the assembly line. A simple header can be used to interface the application circuit to the programmer. This might be more desirable for a manual assembly line where a technician plugs the programmer cable into the board.

A different method is the uses spring loaded test pins (often referred as pogo-pins). The application circuit has pads on the board for each of the programming signals. Then there is a movable fixture that has pogo pins in the same configuration as the pads on the board. The application circuit is moved into position and the fixture is moved such that the spring loaded test pins come into contact with the board. This method might be more suitable for an automated assembly line.

After taking into consideration the issues with the application circuit, the programmer, and the programming environment, anyone can build a high quality, reliable manufacturing line based on ICSP.

OTHER BENEFITS

ICSP provides several other benefits such as calibration and serialization. If program memory permits, it would be cheaper and more reliable to store calibration constants in program memory instead of using an external serial EEPROM.

Field Programming of PICmicro OTP MCUs

An OTP device is not normally capable of being reprogrammed, but the PICmicro architecture gives you this flexibility provided the size of your firmware is less than half that of the desired device.

This method involves using jump tables for the reset and interrupt vectors. Example 1 shows the location of a main routine and the reset vector for the first time a device with 0.5K-words of program memory is programmed. Example 2 shows the location of a second main routine and its reset vector for the second time the same device is programmed. You will notice that the `GOTO Main` that was previously at location 0x0002 is replaced with an NOP. An NOP is a program memory location with all the bits programmed as 0s. When the reset vector is executed, it will execute an NOP and then a `GOTO Main1` instruction to the new code.

EXAMPLE 1: LOCATION OF THE FIRST MAIN ROUTINE AND ITS INTERRUPT VECTOR

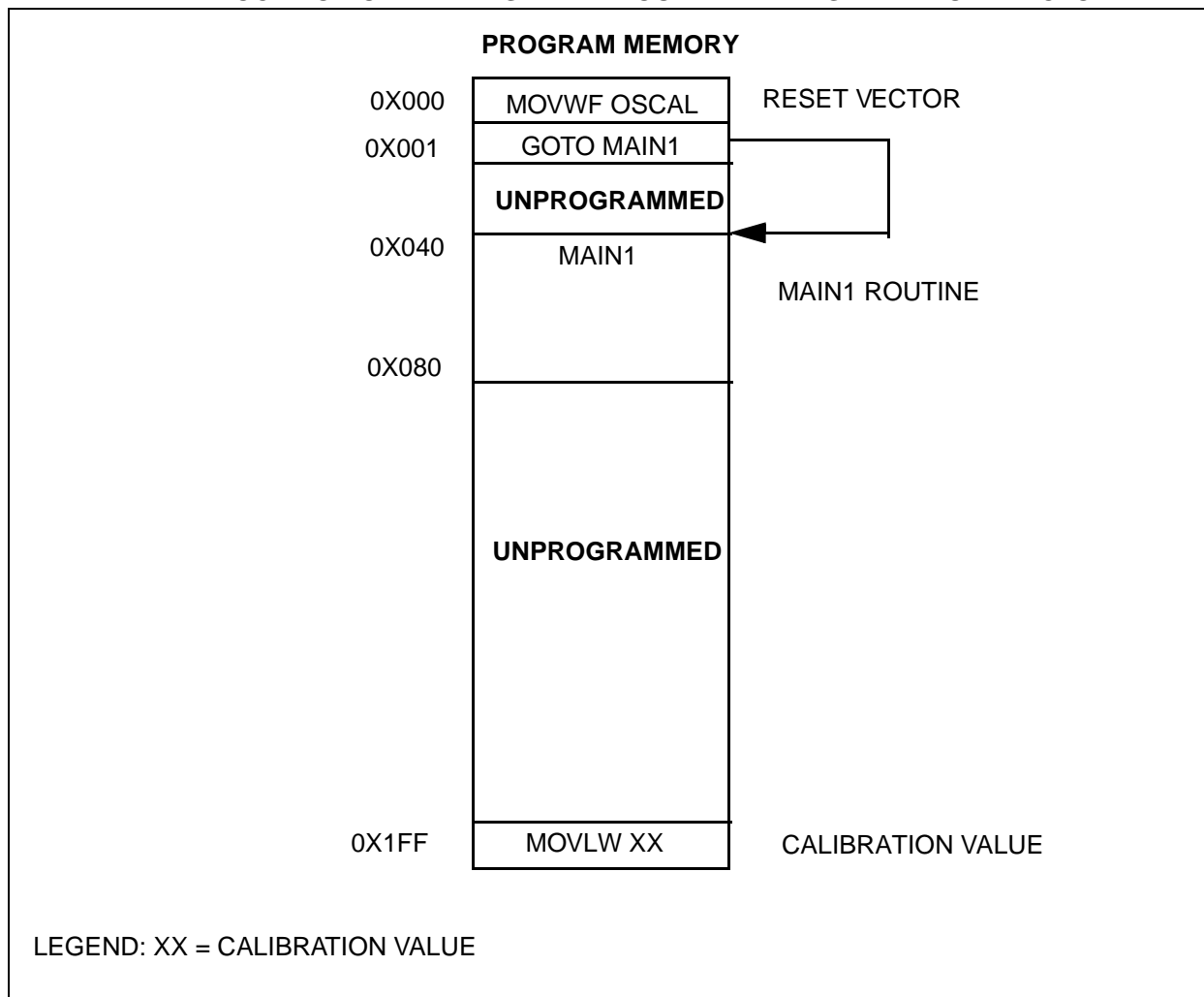

How to Implement ICSP™ Using PIC12C5XX OTP MCUs

EXAMPLE 2: LOCATION OF THE SECOND MAIN ROUTINE AND IT INTERRUPT VECTOR (AFTER SECOND PROGRAMMING)

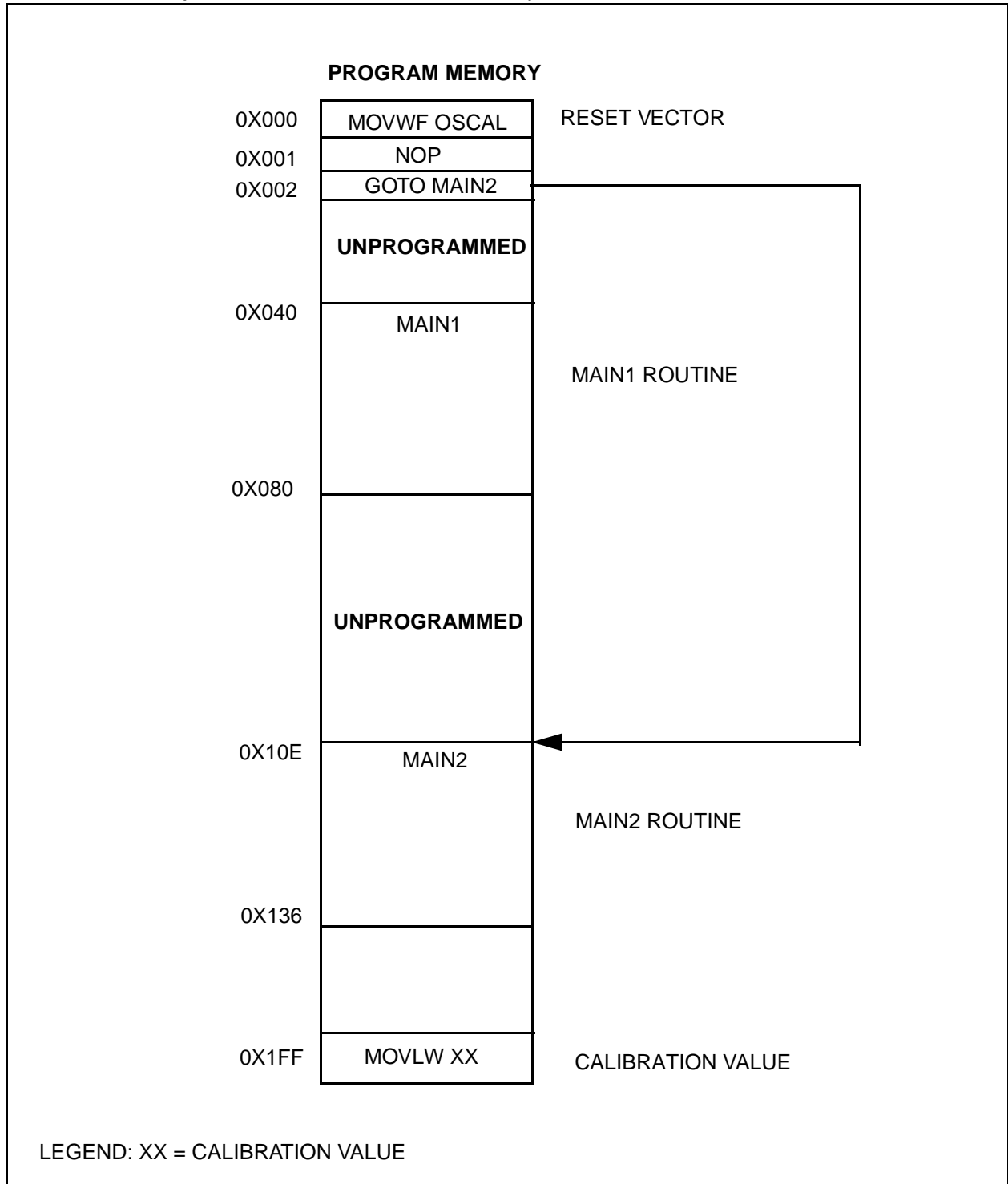

Since the program memory of the PIC12C5XX devices is organized in 256 x 12 word pages, placement of such information as look-up tables and CALL instructions must be taken into account. For further information, please refer to application note *AN581, Implementing Long Calls* and application note *AN556, Implementing a Table Read*.

CONCLUSION

Microchip Technology Inc. is committed to supporting your ICSP needs by providing you with our many years of experience and expertise in developing in-circuit system programming solutions. Anyone can create a reliable in-circuit system programming station by coupling our background with some forethought to the circuit design and programmer selection issues previously mentioned. Your local Microchip representative is available to answer any questions you have about the requirements for ICSP.

How to Implement ICSP™ Using PIC12C5XX OTP MCUs

APPENDIX A: SAMPLE DRIVER BOARD SCHEMATIC

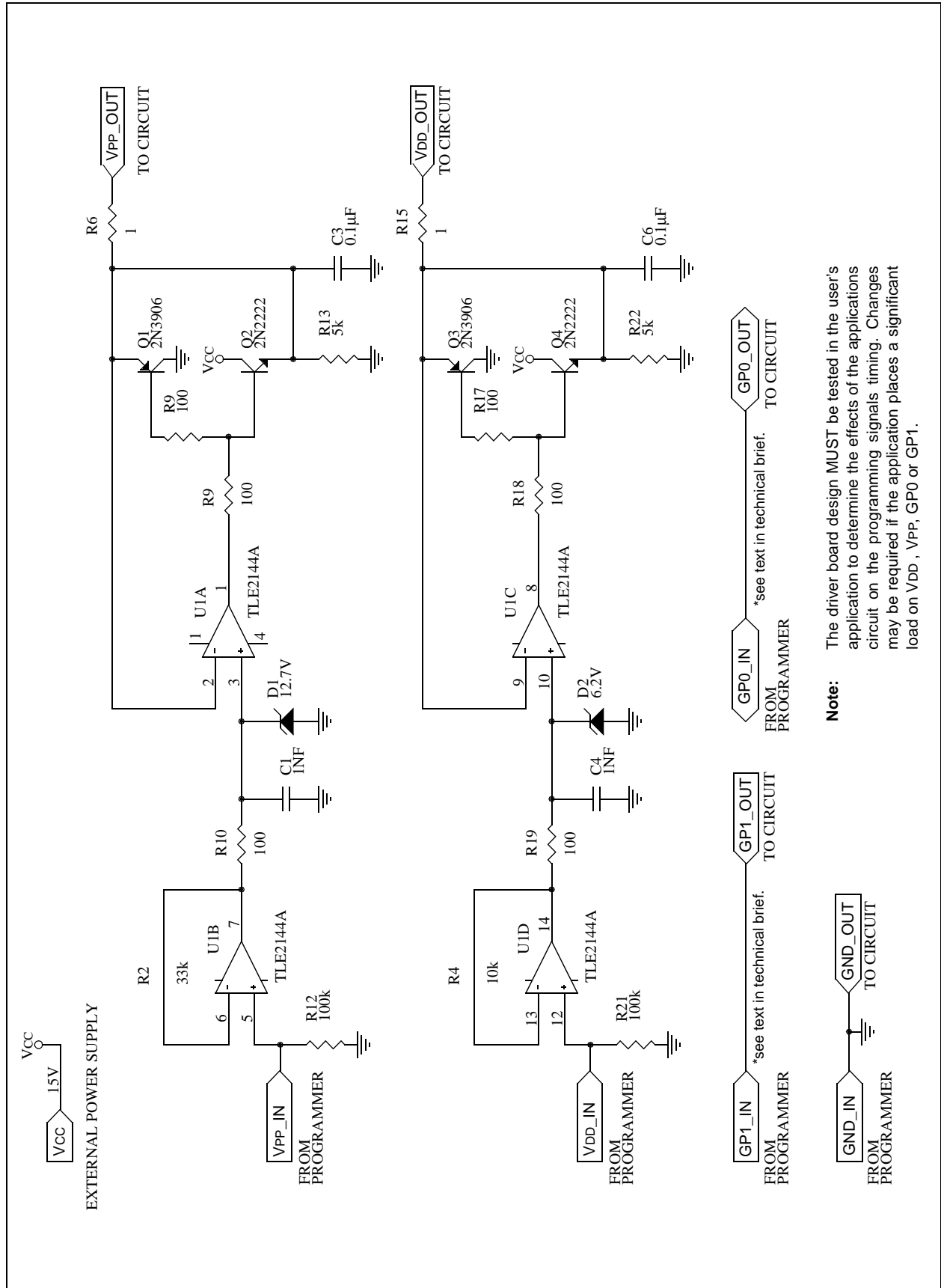



WORLDWIDE SALES AND SERVICE

AMERICAS

Corporate Office

Microchip Technology Inc.
2355 West Chandler Blvd.
Chandler, AZ 85224-6199
Tel: 480-786-7200 Fax: 480-786-7277
Technical Support: 480-786-7627
Web Address: <http://www.microchip.com>

Atlanta

Microchip Technology Inc.
500 Sugar Mill Road, Suite 200B
Atlanta, GA 30350
Tel: 770-640-0034 Fax: 770-640-0307

Boston

Microchip Technology Inc.
5 Mount Royal Avenue
Marlborough, MA 01752
Tel: 508-480-9990 Fax: 508-480-8575

Chicago

Microchip Technology Inc.
333 Pierce Road, Suite 180
Itasca, IL 60143
Tel: 630-285-0071 Fax: 630-285-0075

Dallas

Microchip Technology Inc.
4570 Westgrove Drive, Suite 160
Addison, TX 75248
Tel: 972-818-7423 Fax: 972-818-2924

Dayton

Microchip Technology Inc.
Two Prestige Place, Suite 150
Miamisburg, OH 45342
Tel: 937-291-1654 Fax: 937-291-9175

Detroit

Microchip Technology Inc.
Tri-Atria Office Building
32255 Northwestern Highway, Suite 190
Farmington Hills, MI 48334
Tel: 248-538-2250 Fax: 248-538-2260

Los Angeles

Microchip Technology Inc.
18201 Von Karman, Suite 1090
Irvine, CA 92612
Tel: 949-263-1888 Fax: 949-263-1338

New York

Microchip Technology Inc.
150 Motor Parkway, Suite 202
Hauppauge, NY 11788
Tel: 631-273-5305 Fax: 631-273-5335

San Jose

Microchip Technology Inc.
2107 North First Street, Suite 590
San Jose, CA 95131
Tel: 408-436-7950 Fax: 408-436-7955

AMERICAS (continued)

Toronto

Microchip Technology Inc.
5925 Airport Road, Suite 200
Mississauga, Ontario L4V 1W1, Canada
Tel: 905-405-6279 Fax: 905-405-6253

ASIA/PACIFIC

Beijing

Microchip Technology, Beijing
Unit 915, 6 Chaoyangmen Bei Dajie
Dong Erhuan Road, Dongcheng District
New China Hong Kong Manhattan Building
Beijing 100027 PRC
Tel: 86-10-85282100 Fax: 86-10-85282104

Hong Kong

Microchip Asia Pacific
Unit 2101, Tower 2
Metroplaza
223 Hing Fong Road
Kwai Fong, N.T., Hong Kong
Tel: 852-2-401-1200 Fax: 852-2-401-3431

India

Microchip Technology Inc.
India Liaison Office
No. 6, Legacy, Convent Road
Bangalore 560 025, India
Tel: 91-80-229-0061 Fax: 91-80-229-0062

Japan

Microchip Technology Intl. Inc.
Benex S-1 6F
3-18-20, Shinyokohama
Kohoku-Ku, Yokohama-shi
Kanagawa 222-0033 Japan
Tel: 81-45-471-6166 Fax: 81-45-471-6122

Korea

Microchip Technology Korea
168-1, Youngbo Bldg. 3 Floor
Samsung-Dong, Kangnam-Ku
Seoul, Korea
Tel: 82-2-554-7200 Fax: 82-2-558-5934

Shanghai

Microchip Technology
Unit B701, Far East International Plaza,
No. 317, Xianxia Road
Shanghai, 200051 P.R.C.
Tel: 86-21-6275-5700 Fax: 86-21-6275-5060

ASIA/PACIFIC (continued)

Singapore

Microchip Technology Singapore Pte Ltd.
200 Middle Road
#07-02 Prime Centre
Singapore 188980
Tel: 65-334-8870 Fax: 65-334-8850

Taiwan, R.O.C

Microchip Technology Taiwan
10F-1C 207
Tung Hua North Road
Taipei, Taiwan, ROC
Tel: 886-2-2717-7175 Fax: 886-2-2545-0139

EUROPE

Denmark

Microchip Technology Denmark ApS
Regus Business Centre
Lautrup høj 1-3
Ballerup DK-2750 Denmark
Tel: 45 4420 9895 Fax: 45 4420 9910

France

Arizona Microchip Technology SARL
Parc d'Activite du Moulin de Massy
43 Rue du Saule Trapu
Batiment A - 1er Etage
91300 Massy, France
Tel: 33-1-69-53-63-20 Fax: 33-1-69-30-90-79

Germany

Arizona Microchip Technology GmbH
Gustav-Heinemann-Ring 125
D-81739 München, Germany
Tel: 49-89-627-144 0 Fax: 49-89-627-144-44

Italy

Arizona Microchip Technology SRL
Centro Direzionale Colleoni
Palazzo Taurus 1 V. Le Colleoni 1
20041 Agrate Brianza
Milan, Italy
Tel: 39-039-65791-1 Fax: 39-039-6899883

United Kingdom

Arizona Microchip Technology Ltd.
505 Eskdale Road
Winnersh Triangle
Wokingham
Berkshire, England RG41 5TU
Tel: 44 118 921 5858 Fax: 44-118 921-5835

01/21/00

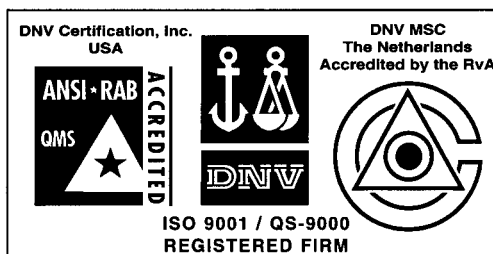

Microchip received QS-9000 quality system certification for its worldwide headquarters, design and wafer fabrication facilities in Chandler and Tempe, Arizona in July 1999. The Company's quality system processes and procedures are QS-9000 compliant for its PICmicro® 8-bit MCUs, KEELoc® code hopping devices, Serial EEPROMs and microperipheral products. In addition, Microchip's quality system for the design and manufacture of development systems is ISO 9001 certified.

All rights reserved. © 2000 Microchip Technology Incorporated. Printed in the USA. 2/00 Printed on recycled paper.

Information contained in this publication regarding device applications and the like is intended through suggestion only and may be superseded by updates. It is your responsibility to ensure that your application meets with your specifications. No representation or warranty is given and no liability is assumed by Microchip Technology Incorporated with respect to the accuracy or use of such information, or infringement of patents or other intellectual property rights arising from such use or otherwise. Use of Microchip's products as critical components in life support systems is not authorized except with express written approval by Microchip. No licenses are conveyed, implicitly or otherwise, except as maybe explicitly expressed herein, under any intellectual property rights. The Microchip logo and name are registered trademarks of Microchip Technology Inc. in the U.S.A. and other countries. All rights reserved. All other trademarks mentioned herein are the property of their respective companies.