



Section 42. Oscillator (Part IV)

HIGHLIGHTS

This section of the manual contains the following topics:

42.1	Introduction	42-2
42.2	CPU Clocking.....	42-4
42.3	Oscillator Configuration Registers	42-5
42.4	Special Function Registers	42-8
42.5	Primary Oscillator (POSC).....	42-15
42.6	Internal FRC Oscillator.....	42-19
42.7	Phase-Locked Loop (PLL)	42-21
42.8	Secondary Oscillator (Sosc)	42-26
42.9	Low-Power RC (LPRC) Oscillator.....	42-27
42.10	Auxiliary PLL Module for ADC and PWM System Clock.....	42-28
42.11	Fail-Safe Clock Monitor (FSCM)	42-30
42.12	Clock Switching.....	42-31
42.13	Two-Speed Start-up	42-35
42.14	Reference Clock Output.....	42-35
42.15	Register Maps	42-36
42.16	Related Application Notes.....	42-37
42.17	Revision History	42-38

Note: This family reference manual section is meant to serve as a complement to device data sheets. Depending on the device variant, this manual section may not apply to all dsPIC33F devices.

Please consult the note at the beginning of the “**Oscillator Configuration**” chapter in the current device data sheet to check whether this document supports the device you are using.

Device data sheets and family reference manual sections are available for download from the Microchip Worldwide Web site at: <http://www.microchip.com>

42.1 INTRODUCTION

The dsPIC33F oscillator system includes the following characteristics:

- External and internal oscillator options
- On-chip Phase-Locked Loop (PLL) to boost internal operating frequency on selected internal and external oscillator sources
- On-chip Auxiliary PLL to boost the internal operating frequency of the PWM and ADC
- On-the-fly clock switching between various clock sources
- Doze mode for system power savings
- Fail-Safe Clock Monitor (FSCM) that detects clock failure and permits safe application recovery or shutdown
- Nonvolatile Configuration bits for clock source selection

A block diagram of the dsPIC33F oscillator system is shown in Figure 42-1.

Figure 42-1: Oscillator System Block Diagram

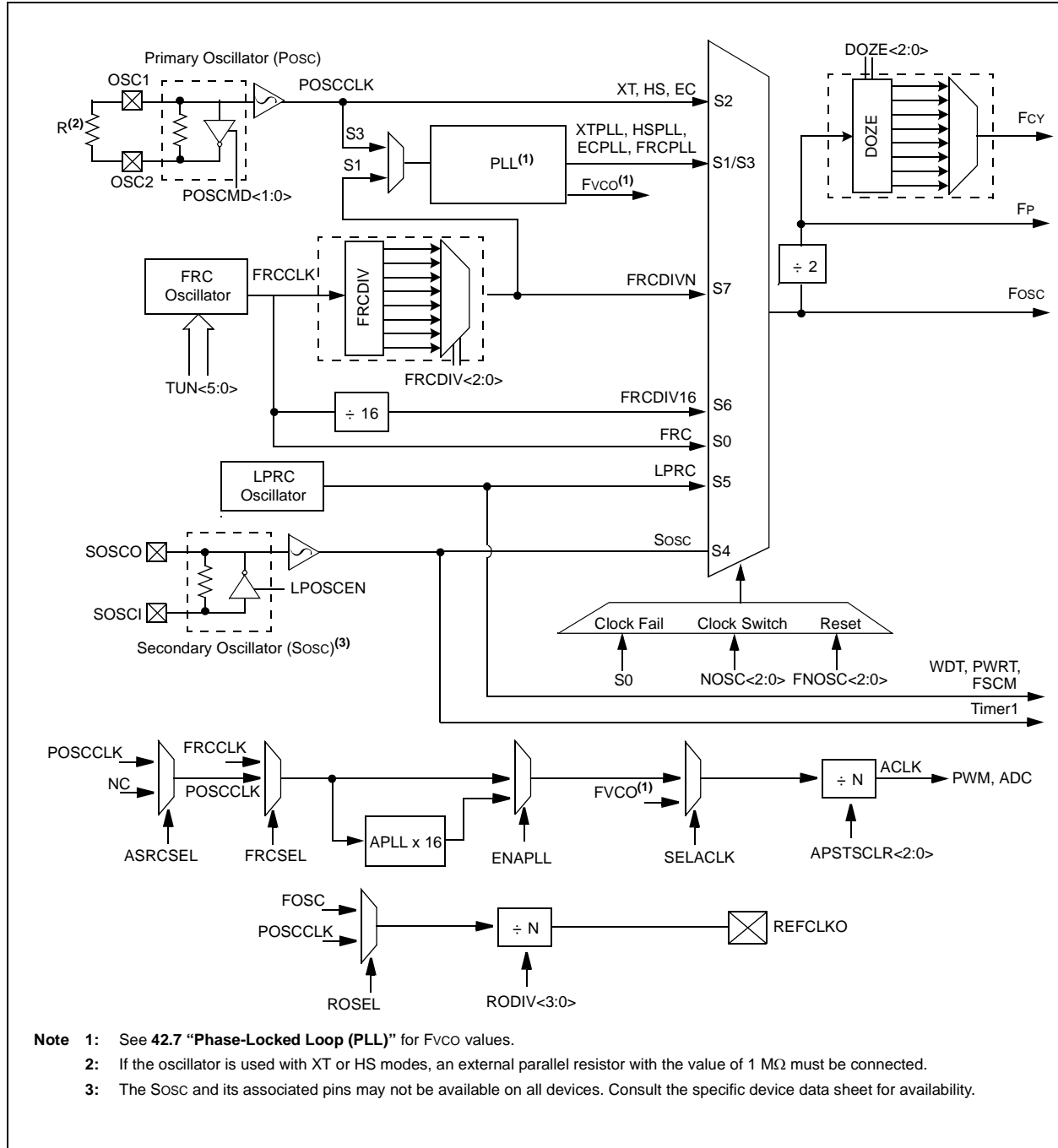

42.2 CPU CLOCKING

The system clock (Fosc) source can be provided by one of the following options:

- Primary Oscillator (Posc) on the OSC1 and OSC2 pins
- Secondary Oscillator (Sosc) on the SOSCI and SOSCO pins
- Internal Fast RC (FRC) Oscillator with optional clock divider
- Internal Low-Power RC (LPRC) Oscillator
- Posc with PLL
- Internal FRC Oscillator with PLL

The Fosc source is divided by 2 to produce the internal instruction cycle clock. In this document, the instruction cycle clock is denoted by Fcy. The timing diagram in Figure 42-2 shows the relationship of the Fosc, the Fcy and the Program Counter (PC).

Fcy can be output on the OSC2 I/O pin if the Primary Oscillator mode or the High Speed Oscillator (HS) mode is not selected as the clock source. Refer to **42.5 “Primary Oscillator (Posc)”** for details about the Posc.

Figure 42-2: Clock/Instruction Cycle Timing

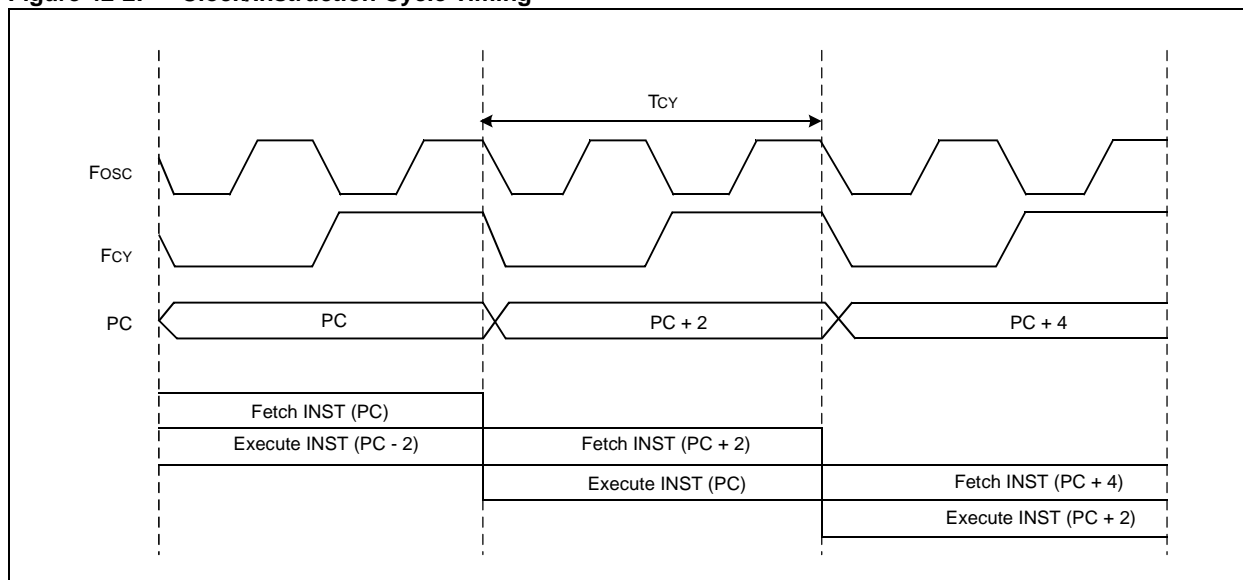

42.3 OSCILLATOR CONFIGURATION REGISTERS

Oscillator Configuration registers are located in the program memory space, and are not Special Function Registers (SFRs). These two registers are mapped into program memory space and are programmed at the time of device programming.

- **FOSCSEL: Oscillator Source Selection Register**

FOSCSEL selects the initial oscillator source and start-up option. FOSCSEL contains the following Configuration bits:

Initial Oscillator Source Selection Configuration bits (FNOSC<2:0>) in the Oscillator Source Selection register (FOSCSEL<2:0>) determine the clock source that is used at a Power-on Reset (POR). Thereafter, the clock source can be changed between permissible clock sources with clock switching.

The Internal FRC Oscillator with postscaler (FRCDIVN) is the default (unprogrammed) selection.

- **FOSC: Oscillator Configuration Register**

FOSC configures the Primary Oscillator mode, OSC2 pin function, peripheral pin select, and the fail-safe and clock switching modes. FOSC contains the following Configuration bits:

- Primary Oscillator Mode Selection Configuration bits (POSCMD<1:0>) in the Oscillator Configuration register (FOSC<1:0>) select the operation mode of the Posc.
- OSC2 Pin Function Configuration bit (OSCIOFNC) in the Oscillator Configuration register (FOSC<2>) selects the OSC2 pin function, except in HS or Medium-Speed Oscillator (XT) mode.

If OSCIOFNC is unprogrammed ('1'), the Fcy clock is output on the OSC2 pin.

If OSCIOFNC is programmed ('0'), the OSC2 pin becomes a general purpose I/O pin.

Table 42-1 lists the configuration settings that select the device oscillator source and operating mode at a POR.

Table 42-1: Configuration Bit Values for Clock Selection

Oscillator Source	Oscillator Mode	FNOSC Value	POSCMD Value	Note
S0	Fast RC Oscillator (FRC)	000	xx	1
S1	Fast RC Oscillator with PLL (FRCPLL)	001	xx	1
S2	Primary Oscillator (EC)	010	00	1
S2	Primary Oscillator (XT)	010	01	—
S2	Primary Oscillator (HS)	010	10	—
S3	Primary Oscillator with PLL (ECPLL)	011	00	1
S3	Primary Oscillator with PLL (XTPLL)	011	01	—
S3	Primary Oscillator with PLL (HSPLL)	011	10	—
S4	Secondary Oscillator (SOSC)	100	xx	3
S5	Low-Power RC Oscillator (LPRC)	101	xx	1
S6	Fast RC Oscillator with /16 divider (FRCDIV16)	110	xx	1
S7	Fast RC Oscillator with /N divider (FRCDIVN)	111	xx	1, 2

- Note 1:** OSC2 pin function is determined by the OSCIOFNC Configuration bit.
Note 2: Default Oscillator mode for an unprogrammed (erased) device.
Note 3: The SOSC may not be available on all devices. See the specific device data sheet for availability.

dsPIC33F Family Reference Manual

Register 42-1: FOSCSEL: Oscillator Source Selection Register

U	U	U	U	U	U	U	U
—	—	—	—	—	—	—	—
bit 15						bit 8	

R/P	U	U	U	U	R/P	R/P	R/P
IESO	—	—	—	—	FNOSC<2:0>		
bit 7						bit 0	

Legend:

R = Readable bit	P = Programmable bit	U = Unused bits, program to Logic '1'
-n = Value at POR	'1' = Bit is set	'0' = Bit is cleared
		x = Bit is unknown

- bit 15-8 **Unimplemented:** Read as '1'
- bit 7 **IESO:** Internal External Start-up Option bit
 - 1 = Start-up device with the Internal FRC Oscillator, then automatically switch to the user-selected oscillator source when ready
 - 0 = Start device with user-selected oscillator source
- bit 6-3 **Unimplemented:** Read as '1'
- bit 2-0 **FNOSC<2:0>:** Initial Oscillator Source Selection bits
 - 111 = Fast RC Oscillator with Divide-by-N (FRCDIVN)
 - 110 = Fast RC Oscillator with Divide-by-16 (FRCDIV16)
 - 101 = Low-Power RC Oscillator (LPRC)
 - 100 = Secondary Oscillator (SOSC)⁽¹⁾
 - 011 = Primary Oscillator with PLL (XTPLL, HSPLL, ECPLL)
 - 010 = Primary Oscillator (XT, HS, EC)
 - 001 = Fast RC Oscillator with PLL (FRCPLL)
 - 000 = Fast RC Oscillator (FRC)

Note 1: This setting is not available on all devices. Consult the specific device data sheet for availability.

Section 42. Oscillator (Part IV)

Register 42-2: FOSC: Oscillator Configuration Register

U	U	U	U	U	U	U	U
—	—	—	—	—	—	—	—
bit 15							bit 8
R/P	R/P	R/P	U	U	R/P	R/P	R/P
FCKSM<1:0>		IOL1WAY ⁽¹⁾	—	—	OSCIOFNC	POSCMD<1:0>	
bit 7							bit 0

Legend:

R = Readable bit	P = Programmable bit	U = Unused bits, program to Logic '1'
-n = Value at POR	'1' = Bit is set	'0' = Bit is cleared x = Bit is unknown

- bit 15-8 **Unimplemented:** Read as '1'
- bit 7-6 **FCKSM<1:0>:** Clock Switching Mode bits
 - 1x = Clock switching is disabled, Fail-Safe Clock Monitor is disabled
 - 01 = Clock switching is enabled, Fail-Safe Clock Monitor is disabled
 - 00 = Clock switching is enabled, Fail-Safe Clock Monitor is enabled
- bit 5 **IOL1WAY:** Peripheral Pin Select Configuration bit⁽¹⁾
 - 1 = Allow only one reconfiguration
 - 0 = Allow multiple reconfigurations
- bit 4-3 **Unimplemented:** Read as '1'
- bit 2 **OSCIOFNC:** OSC2 Pin Function bit (except in XT and HS modes)
 - 1 = OSC2 is clock output and instruction cycle (Fcy) clock is output on OSC2 pin
 - 0 = OSC2 is a general purpose digital I/O pin
- bit 1-0 **POSCMD<1:0>:** Primary Oscillator Mode Selection bits
 - 11 = Primary Oscillator disabled
 - 10 = HS (High-Speed) Crystal Oscillator mode
 - 01 = XT (Crystal) Oscillator mode
 - 00 = EC (External Clock) mode

Note 1: The IOL1WAY bit is not available on all devices. Consult the specific device data sheet for more information.

42.4 SPECIAL FUNCTION REGISTERS

The following SFRs provide run-time control and status of the oscillator system:

- **OSCCON: Oscillator Control Register⁽¹⁾**

OSCCON controls clock switching and provides status information that allows the current clock source, PLL lock and clock fail conditions to be monitored.

- **CLKDIV: Clock Divisor Register**

CLKDIV controls Doze mode and selects the PLL prescaler, PLL postscaler and FRC postscaler.

- **PLLFBF: PLL Feedback Divisor Register**

PLLFBF selects the PLL feedback divisor.

- **OSCTUN: FRC Oscillator Tuning Register**

OSCTUN is used to tune the internal FRC oscillator frequency in software. It allows the FRC oscillator frequency to be adjusted over a range of $\pm 12\%$.

- **ACLKCON: Auxiliary Clock Control Register**

ACLKCON controls the auxiliary PLL mode and the auxiliary PLL clock divider.

- **REFOCON: Reference Oscillator Control Register**

REFOCON controls reference oscillator output.

<p>Note: The Oscillator SFRs (OSCCON, CLKDIV, PLLFBF, OSCTUN, and ACLKCON) are reset only on POR.</p>
--

Section 42. Oscillator (Part IV)

Register 42-3: OSCCON: Oscillator Control Register⁽¹⁾

U-0	R-y	R-y	R-y	U-0	R/W-y	R/W-y	R/W-y
—	COSC<2:0>			—	NOSC<2:0>		
bit 15				bit 8			
R/W-0	R/W-0	R-0	U-0	R/C-0	U-0	U-0	R/W-0
CLKLOCK	IOLOCK	LOCK	—	CF	—	—	OSWEN
bit 7							bit 0

Legend:	y = Value set from Configuration bits on POR
R = Readable bit	W = Writable bit
-n = Value at POR	'1' = Bit is set
	U = Unimplemented bit, read as '0'
	'0' = Bit is cleared
	x = Bit is unknown

- bit 15 **Unimplemented:** Read as '0'
- bit 14-12 **COSC<2:0>:** Current Oscillator Selection bits (read-only)
 - 111 = Fast RC oscillator (FRC) with Divide-by-n
 - 110 = Fast RC oscillator (FRC) with Divide-by-16
 - 101 = Low-Power RC oscillator (LPRC)
 - 100 = Secondary Oscillator (Sosc)⁽²⁾
 - 011 = Primary oscillator (XT, HS, EC) with PLL
 - 010 = Primary oscillator (XT, HS, EC)
 - 001 = Fast RC oscillator (FRC) with PLL
 - 000 = Fast RC oscillator (FRC)
- bit 11 **Unimplemented:** Read as '0'
- bit 10-8 **NOSC<2:0>:** New Oscillator Selection bits
 - 111 = Fast RC oscillator (FRC) with Divide-by-n
 - 110 = Fast RC oscillator (FRC) with Divide-by-16
 - 101 = Low-Power RC oscillator (LPRC)
 - 100 = Secondary Oscillator (Sosc)⁽²⁾
 - 011 = Primary oscillator (XT, HS, EC) with PLL
 - 010 = Primary oscillator (XT, HS, EC)
 - 001 = Fast RC oscillator (FRC) with PLL
 - 000 = Fast RC oscillator (FRC)
- bit 7 **CLKLOCK:** Clock Lock Enable bit
 - If clock switching is enabled and FSCM is disabled, (FOSC<FCKSM> = 0b01)
 - 1 = Clock switching is disabled. System clock source is locked
 - 0 = Clock switching is enabled. System clock source can be modified by clock switching
- bit 6 **IOLOCK:** Peripheral Pin Select Lock bit
 - 1 = Peripheral Pin Select is locked. Write to Peripheral Pin Select registers not allowed
 - 0 = Peripheral Pin Select is not locked. Write to Peripheral Pin Select registers allowed
- bit 5 **LOCK:** PLL Lock Status bit (read-only)
 - 1 = Indicates that PLL is in lock, or PLL start-up timer is satisfied
 - 0 = Indicates that PLL is out of lock, start-up timer is in progress or PLL is disabled
- bit 4 **Unimplemented:** Read as '0'
- bit 3 **CF:** Clock Fail Detect bit (read/clear by application)
 - 1 = FSCM has detected clock failure
 - 0 = FSCM has not detected clock failure
- bit 2-1 **Unimplemented:** Read as '0'
- bit 0 **OSWEN:** Oscillator Switch Enable bit
 - 1 = Request oscillator switch to selection specified by NOSC<2:0> bits
 - 0 = Oscillator switch is complete

Note 1: Writes to this register require an unlock sequence. For details and examples refer to **42.12 “Clock Switching”**.

2: This setting is not available on all devices. Consult the specific device data sheet for availability.

dsPIC33F Family Reference Manual

Register 42-4: CLKDIV: Clock Divisor Register

R/W-0	R/W-0	R/W-1	R/W-1	R/W-0	R/W-0	R/W-0	R/W-0
ROI	DOZE<2:0>			DOZEN ⁽¹⁾	FRCDIV<2:0>		
bit 15				bit 8			

R/W-0	R/W-1	U-0	R/W-0	R/W-0	R/W-0	R/W-0	R/W-0
PLLPOST<1:0>		—	PLLPRE<4:0>				
bit 7							bit 0

Legend:

R = Readable bit	W = Writable bit	U = Unimplemented bit, read as '0'
-n = Value at POR	'1' = Bit is set	'0' = Bit is cleared x = Bit is unknown

- bit 15 **ROI:** Recover on Interrupt bit
 1 = Interrupts will clear the DOZEN bit and the processor clock/peripheral clock ratio is set to 1:1
 0 = Interrupts have no effect on the DOZEN bit
- bit 14-12 **DOZE<2:0>:** Processor Clock Reduction Select bits
 111 = Fcy/128
 110 = Fcy/64
 101 = Fcy/32
 100 = Fcy/16
 011 = Fcy/8 (default)
 010 = Fcy/4
 001 = Fcy/2
 000 = Fcy/1
- bit 11 **DOZEN:** DOZE Mode Enable bit⁽¹⁾
 1 = DOZE<2:0> field specifies the ratio between the peripheral clocks and the processor clocks
 0 = Processor clock/peripheral clock ratio forced to 1:1
- bit 10-8 **FRCDIV<2:0>:** Internal Fast RC Oscillator Postscaler bits
 111 = FRC/256
 110 = FRC/64
 101 = FRC/32
 100 = FRC/16
 011 = FRC/8
 010 = FRC/4
 001 = FRC/2
 000 = FRC/1 (default)
- bit 7-6 **PLLPOST<1:0>:** PLL VCO Output Divider Select bits (also denoted as 'N2', PLL postscaler)
 11 = Output/8
 10 = Reserved
 01 = Output/4 (default)
 00 = Output/2
- bit 5 **Unimplemented:** Read as '0'
- bit 4-0 **PLLPRE<4:0>:** PLL Phase Detector Input Divider Select bits (also denoted as 'N1', PLL prescaler)
 11111 = Input/33
 •
 •
 •
 00001 = Input/3
 00000 = Input/2 (default)

- Note 1:** This bit is cleared when the ROI bit is set and an interrupt occurs.
- 2:** For more information on the DOZE mode, refer to **Section 9. "Watchdog Timer and Power-Saving Modes"** (DS70196) in the *"dsPIC33F Family Reference Manual"*.

Section 42. Oscillator (Part IV)

Register 42-5: PLLFBD: PLL Feedback Divisor Register

U-0	U-0	U-0	U-0	U-0	U-0	U-0	R/W-0
—	—	—	—	—	—	—	PLLDIV<8>
bit 15							bit 8

R/W-0	R/W-0	R/W-1	R/W-1	R/W-0	R/W-0	R/W-0	R/W-0
PLLDIV<7:0>							
bit 7							bit 0

Legend:

R = Readable bit	W = Writable bit	U = Unimplemented bit, read as '0'
-n = Value at POR	'1' = Bit is set	'0' = Bit is cleared x = Bit is unknown

bit 15-9 **Unimplemented:** Read as '0'

bit 8-0 **PLLDIV<8:0>:** PLL Feedback Divisor bits (also denoted as 'M', PLL multiplier)

111111111 = 513

•

•

•

000110000 = 50 (default)

•

•

•

000000010 = 4

000000001 = 3

000000000 = 2

dsPIC33F Family Reference Manual

Register 42-6: OSCTUN: FRC Oscillator Tuning Register

U-0	U-0	U-0	U-0	U-0	U-0	U-0	U-0
—	—	—	—	—	—	—	—
bit 15						bit 8	

U-0	U-0	R/W-0	R/W-0	R/W-0	R/W-0	R/W-0	R/W-0
—	—	TUN<5:0>					
bit 7						bit 0	

Legend:

R = Readable bit W = Writable bit U = Unimplemented bit, read as '0'
 -n = Value at POR '1' = Bit is set '0' = Bit is cleared x = Bit is unknown

bit 15-6 **Unimplemented:** Read as '0'

bit 5-0 **TUN<5:0>:** FRC Oscillator Tuning bits

011111 = Center frequency +11.625% (8.23 MHz)

011110 = Center frequency +11.25% (8.20 MHz)

•

•

•

000001 = Center frequency +0.375% (7.40 MHz)

000000 = Center frequency (7.37 MHz nominal)

111111 = Center frequency -0.375% (7.345 MHz)

•

•

•

100001 = Center frequency -11.625% (6.52 MHz)

100000 = Center frequency -12% (6.49 MHz)

Section 42. Oscillator (Part IV)

Register 42-7: ACLKCON: Auxiliary Clock Control Register

R/W-0	R-0	R/W-1	U-0	U-0	R/W-1	R/W-1	R/W-1
ENAPLL	APLLCK	SELACLK	—	—	APSTSCLR<2:0>		
bit 15							bit 8

R/W-0	R/W-0	U-0	U-0	U-0	U-0	U-0	U-0
ASRCSEL	FRCSEL	—	—	—	—	—	—
bit 7							bit 0

Legend:

R = Readable bit	W = Writable bit	U = Unimplemented bit, read as '0'
-n = Value at POR	'1' = Bit is set	'0' = Bit is cleared
		x = Bit is unknown

- bit 15 **ENAPLL:** Auxiliary PLL Enable bit
 1 = Auxiliary PLL is enabled
 0 = Auxiliary PLL is disabled

- bit 14 **APLLCK:** Auxiliary PLL Locked Status bit (read-only)
 1 = Indicates that Auxiliary PLL is in lock
 0 = Indicates that Auxiliary PLL is not in lock

- bit 13 **SELACLK:** Select Clock Source for Auxiliary Clock Divider bit
 1 = Auxiliary PLL or FRC or Primary Oscillator provides the source clock for the Auxiliary Clock Divider
 0 = PLL output (Fvco) provides the source clock for the Auxiliary Clock Divider

- bit 12-11 **Unimplemented:** Read as '0'

- bit 10-8 **APSTSCLR<2:0>:** Auxiliary Clock Output Divider bits
 111 = Divided by 1
 110 = Divided by 2
 101 = Divided by 4
 100 = Divided by 8
 011 = Divided by 16
 010 = Divided by 32
 001 = Divided by 64
 000 = Divided by 256 (default)

- bit 7 **ASRCSEL:** Select Reference Clock Source for Auxiliary Clock bit
 1 = Primary Oscillator is the clock source
 0 = No clock input is selected

- bit 6 **FRCSEL:** Select Reference Clock Source for Auxiliary Clock bit
 1 = Select FRC clock for Clock Source
 0 = Input clock source is determined by ASRCSEL bit setting

- bit 5-0 **Unimplemented:** Read as '0'

dsPIC33F Family Reference Manual

Register 42-8: REFOCON: Reference Oscillator Control Register

R/W-0	U-0	R/W-0	R/W-0	R/W-0	R/W-0	R/W-0	R/W-0
ROON	—	ROSSLP	ROSEL	RODIV<3:0> ⁽¹⁾			
bit 15				bit 8			

U-0	U-0	U-0	U-0	U-0	U-0	U-0	U-0
—	—	—	—	—	—	—	—
bit 7				bit 0			

Legend:

R = Readable bit W = Writable bit U = Unimplemented bit, read as '0'
 -n = Value at POR '1' = Bit is set '0' = Bit is cleared x = Bit is unknown

bit 15 **ROON:** Reference Oscillator Output Enable bit
 1 = Reference Oscillator output enabled on the REFCLKO pin
 0 = Reference Oscillator output disabled

bit 14 **Unimplemented:** Read as '0'

bit 13 **ROSSLP:** Reference Oscillator Run in Sleep bit
 1 = Reference Oscillator output continues to run in Sleep mode
 0 = Reference Oscillator output is disabled in Sleep mode

bit 12 **ROSEL:** Reference Oscillator Source Select bit
 1 = Oscillator crystal used as the reference clock
 0 = System clock used as the reference clock

bit 11-8 **RODIV<3:0>:** Reference Oscillator Divider bits⁽¹⁾
 1111 = Divided by 32,768
 1110 = Divided by 16,384
 1101 = Divided by 8,192
 1100 = Divided by 4,096
 1011 = Divided by 2,048
 1010 = Divided by 1,024
 1001 = Divided by 512
 1000 = Divided by 256
 0111 = Divided by 128
 0110 = Divided by 64
 0101 = Divided by 32
 0100 = Divided by 16
 0011 = Divided by 8
 0010 = Divided by 4
 0001 = Divided by 2
 0000 = Reference Oscillator source

bit 7-0 **Unimplemented:** Read as '0'

Note 1: The Reference Oscillator module must be disabled (ROON = 0) before writing to these bits.

42.5 PRIMARY OSCILLATOR (Posc)

The Primary Oscillator (Posc) is available on the OSC1 and OSC2 pins of the dsPIC33F device family. This connection enables an external crystal (or ceramic resonator) to provide the clock to the device. Optionally, the internal PLL can be used to boost the system frequency (FOSC) to 80 MHz for 40 MIPS execution. The Posc provides the following modes of operation:

- **Medium-Speed (XT Mode)**

XT mode is a medium-gain, medium-frequency mode used to work with crystal frequencies of 3 to 10 MHz.

- **High-Speed Oscillator (HS Mode)**

HS mode is a high-gain, high-frequency mode used to work with crystal frequencies of 10 to 40 MHz.

- **External Clock Source Operation (EC Mode)**

If the on-chip oscillator is not used, the EC mode allows the internal oscillator to be bypassed. The device clocks are generated from an external source (0.8 to 64 MHz) and input on the OSC1 pin.

The Initial Oscillator Source Selection Configuration bits (FNOSC<2:0>) in the Oscillator Source Selection register (FOSCSEL<2:0>) specify the Posc clock source at POR. The Primary Oscillator Mode Selection Configuration bits (POSCMD<1:0>) in the Oscillator Configuration register (FOSC<1:0>) specify the Primary Oscillator mode. Table 42-2 shows the options selected by specific bit configurations, which are programmed at the time of device programming.

Table 42-2: Primary Oscillator Clock Source Options

FNOSC Value	POSCMD	Primary Oscillator Source/Mode
011	00	Primary Oscillator with PLL: External Clock Mode (ECPLL)
011	01	Primary Oscillator with PLL: Crystal Oscillator with PLL Mode (XTPLL)
011	10	Primary Oscillator with PLL: High-Speed Oscillator with PLL Mode (HSPLL)
010	00	Primary Oscillator: External Clock Mode (EC)
010	01	Primary Oscillator: Crystal Oscillator Mode (XT)
010	10	Primary Oscillator: High-Speed Mode (HS)

Figure 42-3 shows a recommended crystal oscillator circuit diagram for dsPIC33F devices. Capacitors C1 and C2 form the load capacitance for the crystal.

Figure 42-3: Crystal or Ceramic Resonator Operation (XT or HS Oscillator Mode)

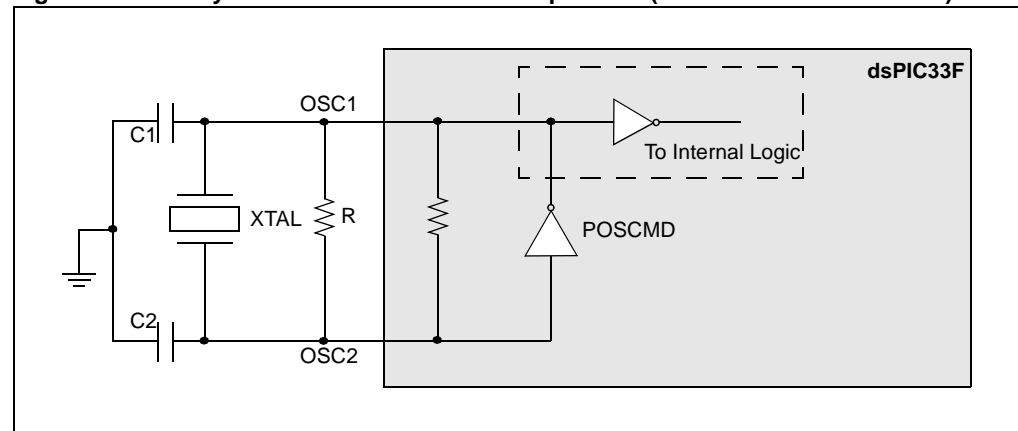

The optimum load capacitance (C_L) for a given crystal is specified by the crystal manufacturer. Load capacitance can be calculated as shown in Equation 42-1.

Equation 42-1: Crystal Load Capacitance

$$C_L = C_S + \frac{C_1 \cdot C_2}{C_1 + C_2}$$

Where:

C_S is the stray capacitance

Assuming $C_1 = C_2$, Equation 42-2 gives the capacitor value (C_1 , C_2) for a given load and stray capacitance.

Equation 42-2: External Capacitor for Crystal

$$C_1 = C_2 = 2 \cdot (C_L - C_S)$$

For additional information on crystal oscillators and their operation, refer to **42.16 “Related Application Notes”**.

42.5.1 Oscillator Start-up Time

The oscillator starts oscillating as the device voltage increases from V_{SS} . The time required for the oscillator to start oscillating depends on the following factors:

- Crystal and resonator frequency
- Capacitor values used (C_1 and C_2 in Figure 42-3)
- Device V_{DD} rise time
- System temperature
- Series resistor value and type, if used
- Oscillator mode selection of device (selects the gain of the internal oscillator inverter)
- Crystal quality
- Oscillator circuit layout
- System noise

Figure 42-4 shows a graph of a typical oscillator/resonator start-up.

Figure 42-4: Example of Oscillator/Resonator Start-up Characteristics

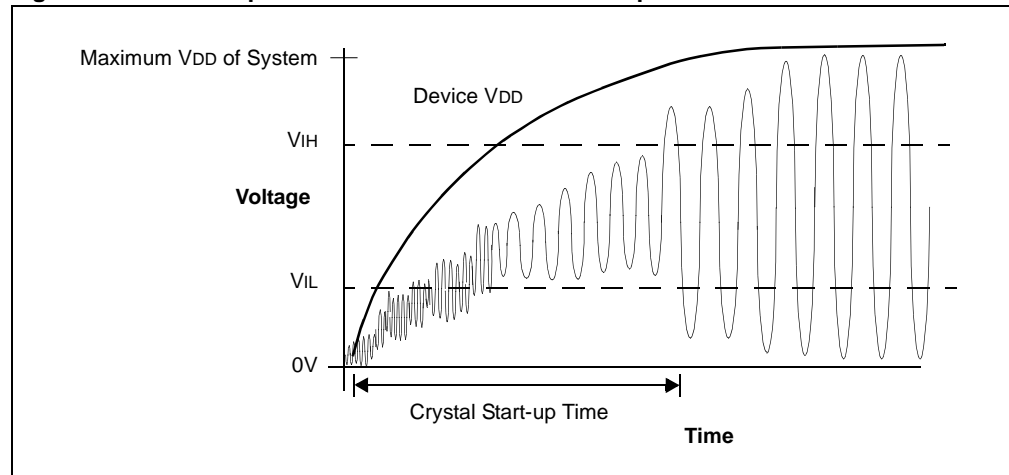

To ensure that a crystal oscillator (or ceramic resonator) has started and stabilized, an Oscillator Start-up Timer (OST) is provided with the P_{OSC} and S_{OSC} . The OST is a simple 10-bit counter that counts 1024 cycles before releasing the oscillator clock to the rest of the system. This time-out period is denoted as T_{OST} .

Section 42. Oscillator (Part IV)

The amplitude of the oscillator signal must reach the V_{IL} and V_{IH} thresholds for the oscillator pins before the OST can begin to count cycles. The T_{OST} interval is required every time the oscillator restarts (i.e., on POR, BOR, and wake-up from Sleep mode).

Once the POSC is enabled, it takes a finite amount of time to start oscillating. This delay is denoted as T_{OSCD} . After T_{OSCD} , the OST timer takes 1024 clock cycles (T_{OST}) to release the clock. The total delay for the clock to be ready is $T_{OSCD} + T_{OST}$. If the PLL is used, an additional delay is required for the PLL to lock (see 42.7 “Phase-Locked Loop (PLL)”).

POSC start-up behavior is illustrated in Figure 42-5, where the CPU starts toggling an I/O pin when it starts execution after the $T_{OSCD} + T_{OST}$ interval.

Figure 42-5: Oscillator Start-up Characteristics

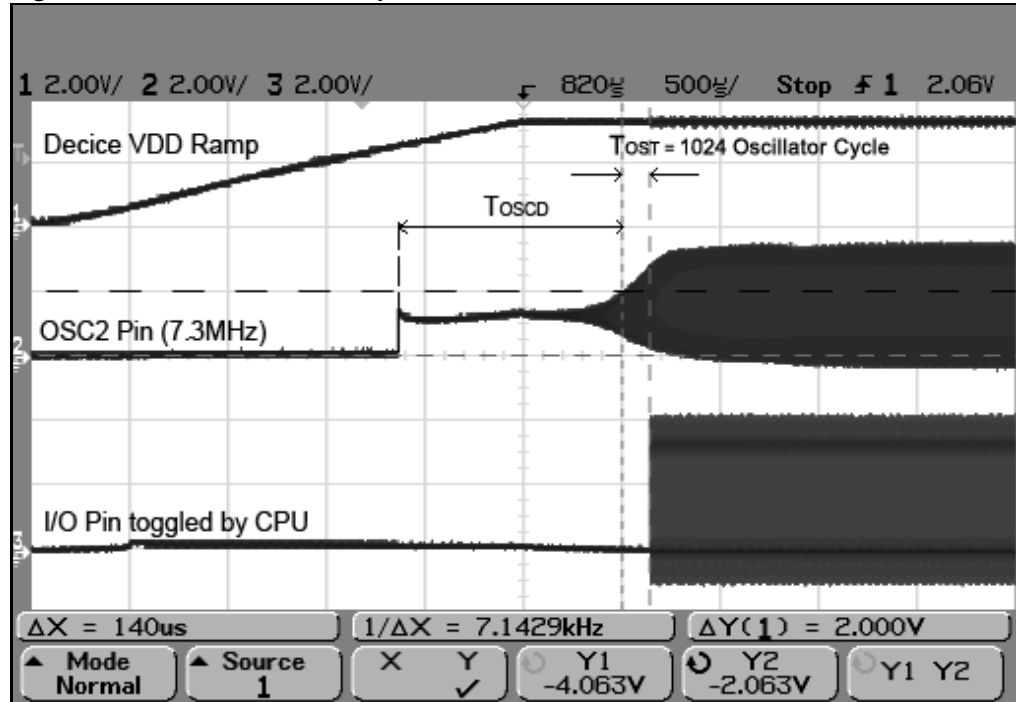

42.5.2 Primary Oscillator Pin Functionality

The Primary Oscillator pins (OSC1/OSC2) can be used for other functions when the oscillator is not being used.

The POSCMD Configuration bits in the Oscillator Configuration register (FOSC<1:0>) determine the oscillator pin function.

The OSCIOFNC bit (FOSC<2>) determines the OSC2 pin function. When FOSC<2> is '0', OSC2 is a general purpose digital I/O pin (see Figure 42-6). When FOSC<2> is '1', OSC2 is a clock output and the instruction cycle (FCY) clock is output on the OSC2 pin (see Figure 42-7).

The oscillator pin functions are shown in Table 42-3.

Table 42-3: Clock Pin Function Selection

Oscillator Source	OSCIOFNC<2> Value	POSCMD<1:0> Value	OSC1 ⁽¹⁾ Pin Function	OSC2 ⁽²⁾ Pin Function
Primary OSC Disabled	1	11	Digital I/O	Clock Output (FCY)
Primary OSC Disabled	0	11	Digital I/O	Digital I/O
HS (High-Speed)	X	10	OSC1	OSC2
XT (Crystal)	X	01	OSC1	OSC2
EC (External Clock)	1	00	OSC1	Clock Output (FCY)
EC (External Clock)	0	00	OSC1	Digital I/O

- Note 1:** OSC1 pin function is determined by the Primary Oscillator Mode Configuration bits (POSCMD<1:0>).
- 2:** OSC1 pin function is determined by the Primary Oscillator Mode Configuration bits (POSCMD<1:0>) and OSC2 Pin Function Configuration bits (OSCIOFNC<2>).

Figure 42-6: OSC2 Pin for Digital I/O (in EC Mode), FOSC<2> = 0

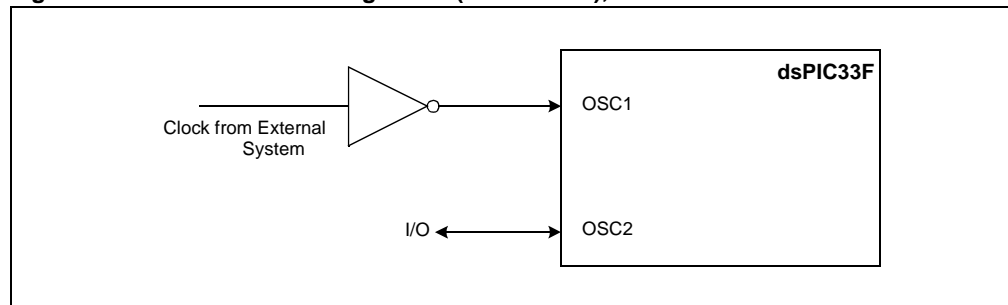
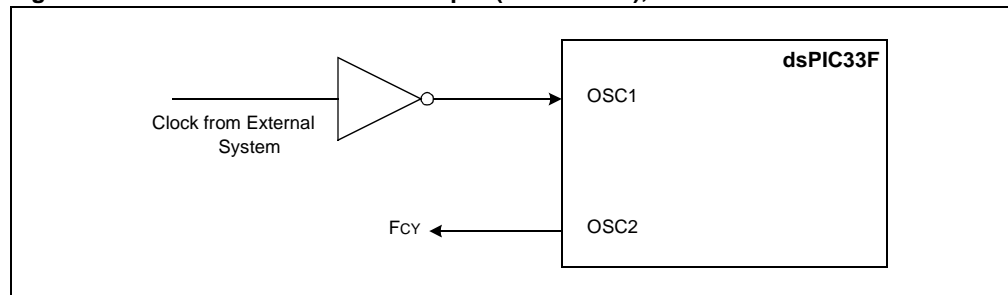

Figure 42-7: OSC2 Pin for Clock Output (in EC Mode), FOSC<2> = 1



42.6 INTERNAL FRC OSCILLATOR

The Internal FRC Oscillator provides a nominal 7.37 MHz clock without requiring an external crystal or ceramic resonator, which results in system cost savings for applications that do not require a precise clock reference.

The application software can tune the frequency of the oscillator from -12% to +11.625% (30 kHz steps) of the nominal frequency value using the FRC Oscillator Tuning bits (TUN<5:0>) in the FRC Oscillator Tuning register (OSCTUN<5:0>). The nominal or tuned frequency of the FRC Oscillator is expected to remain within $\pm 2\%$ of the tuned value over temperature and voltage variations of a particular device.

Note 1: Refer to the specific device data sheet for the accuracy of the FRC clock frequency over temperature and voltage variations.

2: The FRC Oscillator Tuning (TUN<5:0>) bits should not be changed dynamically when operating in internal FRC with PLL.

To change the FRC Oscillator Tuning bits:

- a) Switch the clock to a non-PLL mode (e.g., Internal FRC).
- b) Make the necessary changes.
- c) Switch the clock back to the PLL mode.

The Internal FRC Oscillator starts up instantly. Unlike a crystal oscillator, which can take several milliseconds to begin oscillation, the Internal FRC starts oscillating immediately.

The Initial Oscillator Source Selection Configuration bits (FNOSC<2:0>) in the Oscillator Source Selection register (FOSCSEL<2:0>) select the FRC clock source. The FRC clock source options at the time of a POR are shown in Table 42-4. The Configuration bits are programmed at the time of device programming.

Table 42-4: FRC Clock Source Options

FNOSC<2:0> Value	Primary Oscillator Source/Mode
111	FRC Oscillator: Postscaler divide by N (FRCDIVN)
110	FRC Oscillator: Postscaler divide by 16 (FRCDIV16)
001	FRC Oscillator with PLL (FRCPLL)
000	FRC Oscillator (FRC)

42.6.1 FRC Postscaler Mode (FRCDIVN)

In FRC Postscaler mode, a variable postscaler divides the FRC clock output and allows a lower frequency to be chosen. The postscaler is controlled by the Internal Fast RC Oscillator Postscaler bits (FRCDIV<2:0>) in the Clock Divisor register (CLKDIV<10:8>). These bits allow for eight settings, from 1:1 to 1:256, as shown in Figure 42-5.

Table 42-5: Internal Fast RC Oscillator Postscaler Settings

FRCDIV<2:0> Value	Internal FRC Oscillator Setting
111	FRC divide by 256
110	FRC divide by 64
101	FRC divide by 32
100	FRC divide by 16
011	FRC divide by 8
010	FRC divide by 4
001	FRC divide by 2
000	FRC divide by 1 (default)

Optionally, the FRC postscaler output can be used with the internal PLL to boost the system frequency (Fosc) to 80 MHz for 40 MIPS instruction cycle execution speed.

Note: The FRC Divider should not be changed dynamically when operating in internal FRC with PLL.

To change the FRC divider:

1. Switch the clock to a non-PLL mode (e.g., Internal FRC).
2. Make the necessary changes.
3. Switch the clock back to the PLL mode.

42.7 PHASE-LOCKED LOOP (PLL)

The POSC and Internal FRC Oscillator sources can also be used with an on-chip PLL to obtain higher operating speeds. A block diagram of the PLL module is shown in Figure 42-8.

Figure 42-8: dsPIC33F PLL Block Diagram

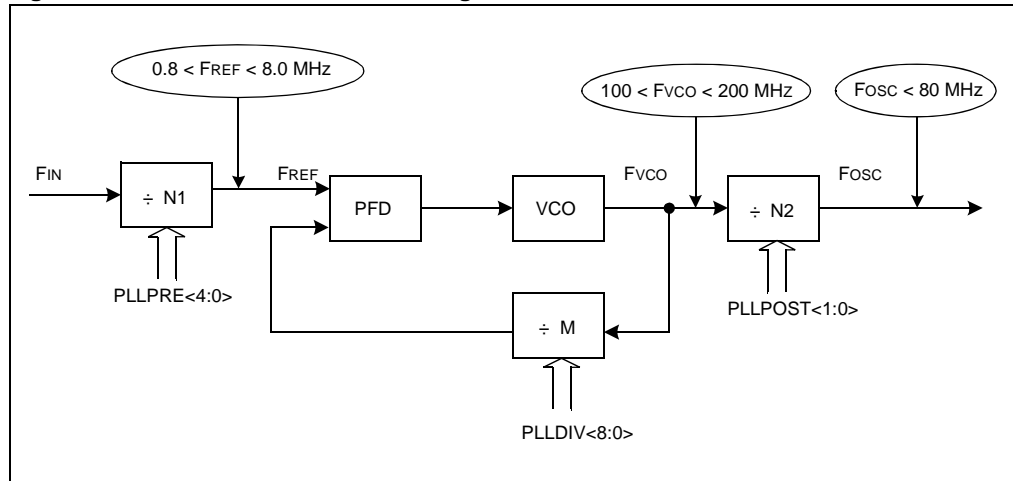

For proper PLL operation, the Phase Frequency Detector (PFD) input frequency and Voltage Controlled Oscillator (VCO) output frequency must meet the following requirements:

- The PFD input frequency (FREF) must be in the range of 0.8 to 8.0 MHz
- The VCO output frequency (FVCO) must be in the range of 100 to 200 MHz

The PLL Phase Detector Input Divider Select bits (PLLPRE<4:0>) in the Clock Divisor register (CLKDIV<4:0>) specify the input divider ratio (N1), which is used to scale down the input clock (FIN) to meet the PFD input frequency range of 0.8 to 8 MHz.

The PLL Feedback Divisor bits (PLLDIV<8:0>) in the PLL Feedback Divisor register (PLLFBD<8:0>) specify the divider ratio (M), which scales down the VCO frequency (FVCO) for feedback to the PFD. The VCO frequency (FVCO) is 'M' times the input reference clock (FREF).

The PLL VCO Output Divider Select bits (PLLPOST<1:0>) in the Clock Divisor register (CLKDIV<7:6>) specify the divider ratio (N2) to limit the system clock frequency (FOSC) to 80 MHz.

Equation 42-3 shows the relation between the input frequency (FIN) and the output frequency (FOSC).

Equation 42-3: Fosc Calculation

$$F_{OSC} = F_{IN} \times \left(\frac{M}{N1 \times N2} \right) = F_{IN} \times \left(\frac{(PLLDIV + 2)}{(PLLPRE + 2) \times 2(PLLPOST + 1)} \right)$$

Where:

$$N1 = PLLPRE + 2$$

$$N2 = 2 \times (PLLPOST + 1)$$

$$M = PLLDIV + 2$$

Equation 42-4 shows the relation between the input frequency (FIN) and the VCO frequency (FVCO).

Equation 42-4: Fvco Calculation

$$F_{VCO} = F_{IN} \times \left(\frac{M}{N1} \right) = F_{IN} \times \left(\frac{(PLLDIV + 2)}{(PLLPRE + 2)} \right)$$

42.7.1 Input Clock Limitation at Start-up for PLL Mode

Table 42-6 gives the default values of the PLL Prescaler, PLL Postscaler, and PLL Feedback Divisor Configuration bits at a POR.

Table 42-6: PLL Mode Defaults

Register	Bit Field	Value at POR Reset	PLL Divider Ratio
CLKDIV<4:0>	PLLPRE<4:0>	00	N1 = 2
CLKDIV<7:6>	PLLPOST<1:0>	01	N2 = 4
PLLFBD<8:0>	PLLDIV<8:0>	000110000	M = 50

Given these Reset values, the following equations show the relation between the input frequency (F_{IN}) and PFD input frequency (F_{REF}), and the VCO frequency (F_{VCO}) and system clock frequency (F_{OSC}) at a POR.

Equation 42-5: F_{REF} at POR

$$F_{REF} = F_{IN} \left(\frac{1}{N1} \right) = 0.5(F_{IN})$$

Equation 42-6: F_{VCO} at POR

$$F_{VCO} = F_{IN} \left(\frac{M}{N1} \right) = F_{IN} \left(\frac{50}{2} \right) = 25(F_{IN})$$

Equation 42-7: F_{OSC} at POR

$$F_{OSC} = F_{IN} \left(\frac{M}{N1 \cdot N2} \right) = 6.25(F_{IN})$$

Given the preceding equations at POR, the input frequency (F_{IN}) to the PLL module must be limited to $4 \text{ MHz} < F_{IN} < 8 \text{ MHz}$ to comply with the VCO output frequency requirement ($100\text{M} < F_{VCO} < 200\text{M}$), if the default values of PLLPRE, PLLPOST, and PLLDIV are used.

The POSC can support the following input frequency ranges, which are not within the frequency limit required ($4 \text{ MHz} < F_{IN} < 8 \text{ MHz}$) at a POR:

- POSC in XT Mode supports: 3-10 MHz crystal
- POSC in HS Mode supports: 10-40 MHz crystal
- POSC in EC Mode supports: 0.8-64 MHz input

To use the PLL when the input frequency is not within the 4-8 MHz range, follow the process given below:

1. Power-up the device with Internal FRC or Primary Oscillator, without a PLL.
2. Change the PLLDIV, PLLPRE, and PLLPOST bit values, based on the input frequency, to meet these PLL requirements:
 - F_{REF} must be in the range of 0.8-8.0 MHz
 - F_{VCO} must be in the range of 100-200 MHz
3. Switch the clock to the PLL mode in software.

42.7.2 PLL Lock Status

Whenever the PLL input frequency, the PLL prescaler or the PLL feedback divisor, is changed, the PLL requires a finite amount of time (TLOCK) to synchronize to the new settings.

TLOCK is applied when the PLL is selected as the clock source at POR, or during a clock switching operation. The value of TLOCK is relative to the time at which the clock is available to the PLL input. For example, with the Posc, TLOCK starts after the OST delay. Refer to **42.5.1 “Oscillator Start-up Time”** for detailed information about start-up delay. Refer to the specific device data sheet for information about typical TLOCK values.

The PLL Lock Status (LOCK) bit in the Oscillator Control (OSCCON<5>) register is a read-only bit that indicates the Lock status of the PLL. The LOCK bit is cleared at POR and on a clock-switch operation, when the PLL is selected as the destination clock source. It remains clear when any clock source not using the PLL is selected. It is a good practice to wait for the LOCK bit to be set before executing code after a clock switch event in which the PLL is enabled.

Note: The PLL Prescaler (PLLPRE) and PLL Feedback Divisor (PLLDIV) should not be changed when operating in PLL mode. You must clock switch to a non-PLL mode (e.g., Internal FRC), to make the necessary changes, and then clock switch back to the PLL mode.

42.7.2.1 SETUP FOR USING PLL WITH THE Posc

The following process can be used to set up the PLL to operate the device at 40 MIPS with a 10 MHz external crystal:

1. To execute instructions at 40 MHz, ensure that the required system clock frequency is $F_{osc} = 2 \cdot F_{CY} = 80 \text{ MHz}$.
2. Ensure that the default Reset values of PLLPRE, PLLPOST, and PLLDIV meet PLL and user requirements:
3. If the PLL and user requirements are met, directly configure the FNOSC bits (FOSCSEL<2:0>) to select the Primary Oscillator with PLL at POR.

If the PLL and user requirements are not met, follow these steps:

- a) Select the PLL postscaler to meet the VCO output frequency requirement ($100 < F_{VCO} < 200 \text{ MHz}$).
- b) Select the PLL prescaler to meet the PFD input frequency requirement ($0.8 < F_{REF} < 8 \text{ MHz}$).
- c) Select the PLL feedback divisor to generate the required VCO output frequency based on the PFD input frequency.
- d) Configure the FNOSC bits (FOSCSEL<2:0>) to select a clock source without the PLL (e.g., Internal FRC) at POR.
- e) In the main program, change the PLL prescaler, PLL postscaler, and PLL feedback divisor values to the values obtained in the previous steps, and then perform a clock switch to the PLL mode.

Example 42-1 illustrates the code for using PLL with the POSC. See 42.12 “Clock Switching” for a clock switching code example.

Example 42-1: Code Example for Using PLL with Posc

```
// Select Internal FRC at POR
_FOSCSEL(FNOSC_FRC);

// Enable Clock Switching and Configure POSC in XT mode
_FOSC(FCKSM_CSECMD & OSCIOFNC_OFF & POSCMD_XT);

int main()
{

// Configure PLL prescaler, PLL postscaler, PLL divisor
PLLFBD=30;           // M = 32
CLKDIVbits.PLLPOST=0; // N2 = 2
CLKDIVbits.PLLPRE=0; // N1 = 2

// Initiate Clock Switch to Primary Oscillator with PLL (NOSC = 0b011)
__builtin_write_OSCCONH(0x03);
__builtin_write_OSCCONL(0x01);

// Wait for Clock switch to occur
while (OSCCONbits.COSC != 0b011);

// Wait for PLL to lock
while(OSCCONbits.LOCK!=1) {};

}
```

42.7.2.2 SETUP FOR USING PLL WITH 7.37 MHz INTERNAL FRC

The following process can be used to set up the PLL to operate the device at 40 MIPS with a 7.37 MHz Internal FRC.

1. To execute instructions at 40 MHz, ensure that the system clock frequency is $F_{OSC} = 2 \cdot F_{CY} = 80 \text{ MHz}$.
2. Ensure that the default Reset values of PLLPRE, PLLPOST, and PLLDIV meet PLL and user requirements:
3. If the PLL and user requirements are met, directly configure the FNOSC bits (FOSCSEL<2:0>) to select the Posc with PLL at a POR.

If the PLL and user requirements are not met, follow these steps:

- a) Select the PLL postscaler to meet the VCO output frequency requirement ($100 < F_{VCO} < 200 \text{ MHz}$).
- b) Select the PLL prescaler to meet the PFD input frequency requirement ($0.8 < F_{REF} < 8 \text{ MHz}$).
- c) Select the PLL feedback divisor to generate the required VCO output frequency based on the PFD input frequency.
- d) Configure the FNOSC bits (FOSCSEL<2:0>) to select a clock source without the PLL (e.g., Internal FRC Oscillator) at POR.
- e) In the main program, change the PLL prescaler, PLL postscaler, and PLL feedback divisor to meet the PLL and user requirements, and then perform a clock switch to the PLL mode.

Example 42-2 illustrates the code for using PLL with a 7.37 MHz Internal FRC. See 42.12 “Clock Switching” for a clock switching code example.

Example 42-2: Code Example for Using the PLL with 7.37 MHz Internal FRC Oscillator

```
// Select Internal FRC at POR
_FOSCSEL(FNOSC_FRC);

// Enable Clock Switching and Configure
_FOSC(FCKSM_CSECMD & OSCIOFNC_OFF);

int main()
{

// Configure PLL prescaler, PLL postscaler, PLL divisor
PLLFBFBD = 41;           // M = 43
CLKDIVbits.PLLPOST=0; // N2 = 2
CLKDIVbits.PLLPRE=0;   // N1 = 2

// Initiate Clock Switch to Internal FRC with PLL (NOSC = 0b001)
__builtin_write_OSCCONH(0x01);
__builtin_write_OSCCONL(0x01);

// Wait for Clock switch to occur
while (OSCCONbits.COSC != 0b001);

// Wait for PLL to lock
while(OSCCONbits.LOCK!=1) {};

}
```

42.8 SECONDARY OSCILLATOR (Sosc)

The Secondary Oscillator (Sosc) enables a 32.768 kHz crystal oscillator to be attached to the dsPIC33F device as a secondary crystal clock source for low-power operation. It uses the SOSCI and SOSCO pins. The Sosc can also drive Timer1 for Real-Time Clock (RTC) applications.

Note 1: The SOSC is sometimes referred to as the Low-Power Secondary Oscillator due to its low-power capabilities. However, this oscillator should not be confused with the Low-Power RC (LPRC) Oscillator.

2: In addition, this oscillator is not available on all devices. Consult the specific device data sheet for availability.

42.8.1 Sosc for System Clock

The Sosc is enabled as the system clock when:

- Initial Oscillator Source Selection Configuration bits (FNOSC<2:0>) in the Oscillator Source Selection register (FOSCSEL<2:0>) are appropriately set to select the Sosc at a POR
- User application initiates a clock switch to the SOSC for low-power operation

When the Sosc is not being used to provide the system clock, or the device enters Sleep mode, the Sosc is disabled to save power.

42.8.2 Sosc Start-up Delay

When the SOSC is enabled, it takes a finite amount of time to start oscillating. Refer to 42.5.1 “Oscillator Start-up Time” for details.

42.8.3 Continuous Sosc Operation

Optionally, you can leave the Sosc running continuously. The SOSC is always enabled if the Secondary Oscillator Enable bit (LPOSCEN) is set in the Oscillator Control register (OSCCON<1>).

There are two reasons to leave the SOSC running.

- First, keeping the Sosc always on allows a fast switch to the 32 kHz system clock for lower-power operation, since returning to the faster main oscillator still requires an oscillator start-up time if it is a crystal type source (see 42.5.1 “Oscillator Start-up Time”).
- Second, the oscillator should remain on continuously when Timer1 is used as an RTC.

Note: In Sleep mode, all clock sources (the POSC, Internal FRC Oscillator, and LPRC Oscillator) are shut down, with the exception of the SOSC. The SOSC can be active in Sleep mode if the Secondary Oscillator Enable bit (LPOSCEN) is set in the Oscillator Control register (OSCCON<1>).

42.9 LOW-POWER RC (LPRC) OSCILLATOR

The Low-Power RC (LPRC) Oscillator provides a nominal clock frequency of 32 kHz. The LPRC oscillator is the clock source for the Power-Up Timer (PWRT), Watchdog Timer (WDT), and Fail-Safe Clock Monitor (FSCM) circuits. It can also be used to provide a low-frequency clock source option for the device in those applications where power consumption is critical and timing accuracy is not required.

Note: The clock frequency of the LPRC Oscillator will vary depending on the device voltage and operating temperature. Refer to the “**Electrical Characteristics**” section in the specific device data sheet for details.

42.9.1 LPRC Oscillator for System Clock

The LPRC Oscillator is selected as the system clock in the following conditions:

- Initial Oscillator Source Selection bits (FNOSC<2:0>) in the Oscillator Source Selection register (FOSCSEL<2:0>) are appropriately set to select the LPRC oscillator at a POR
- User software initiates a clock switch to the LPRC Oscillator for low-power operation

42.9.2 Enabling the LPRC Oscillator

The LPRC Oscillator is the clock source for the PWRT, WDT, and FSCM.

The LPRC Oscillator is enabled on a POR, if the Power-on Reset Timer Value Select bits (FPWRT) in the POR Configuration Fuse register (FPOR<2:0>) are set.

The LPRC oscillator remains enabled under these conditions:

- FSCM is enabled
- WDT is enabled
- LPRC Oscillator is selected as the system clock

If none of these conditions is true, the LPRC Oscillator shuts off after the PWRT expires. The LPRC Oscillator is shut off in Sleep mode.

Note: The LPRC Oscillator runs in Sleep mode only if the WDT is enabled. Under all other conditions, the LPRC Oscillator is disabled in Sleep mode.

42.9.3 LPRC Oscillator Start-up Delay

The LPRC Oscillator starts up instantly, unlike a crystal oscillator, which can take several milliseconds to begin oscillation.

42.10 AUXILIARY PLL MODULE FOR ADC AND PWM SYSTEM CLOCK

The Auxiliary PLL can be used to provide a high-speed clock to peripherals such as the PWM and the ADC. The ACLKCON register selects the reference clock and output dividers for obtaining the necessary auxiliary clock for the PWM and ADC modules. The auxiliary clock for the PWM and ADC can be either:

- Internal FRC Oscillator (7.37 MHz nominal)
- Primary Oscillator
- Internal FRC Oscillator with PLL
- Primary Oscillator with PLL
- Auxiliary PLL

42.10.1 Enabling the Auxiliary PLL

To enable the Auxiliary PLL, the following steps must be performed:

1. Select the reference clock for the Auxiliary PLL by setting the ASRCSEL bit (ACLKCON<7>) for the POSC or by setting the FRCSEL bit (ACLKCON<6>) for the Internal FRC Oscillator.
2. Enable the Auxiliary PLL by setting the ENAPLL bit (ACLKCON<15>).
3. Select the clock source for the auxiliary clock output divider by setting the SELACLK bit (ACLKCON<13>).
4. Select the appropriate clock divider by setting the APSTSCLR<2:0> bits (ACLKCON<10:8>).
5. Ensure that the Auxiliary PLL has locked and is ready for operation. This is done by polling the APLLCK bit (ACLKCON<14>).

See Example 42-3 for a code example to set up the Auxiliary PLL for 120 MHz, using the Internal FRC Oscillator as a clock reference.

Example 42-3: Enabling the Auxiliary PLL

```
ACLKCONbits.FRCSEL = 1; /* Internal FRC is clock source for auxiliary PLL */
ACLKCONbits.ENAPLL = 1; /* APLL is enabled */
ACLKCONbits.SELACLK = 1; /* Auxiliary PLL provides the source clock for the */
                        /* clock divider */
ACLKCONbits.APSTSCLR = 7; /* Auxiliary Clock Output Divider is Divide by 1 */

while(ACLKCONbits.APLLCK != 1){}; /* Wait for Auxiliary PLL to Lock */

/* Given a 7.5MHz input from the FRC the Auxiliary Clock for the ADC and PWM */
/* modules are 7.5MHz * 16 = 120MHz */
```

Note 1: If the Primary PLL is used as a source for the auxiliary clock, then the Primary PLL should be configured up to a maximum operation of 30 MIPS or less.

2: By using various combinations of clock inputs and PLL settings, it is possible to configure the oscillator out of specification. The user application must ensure that ACLK is configured to be within the electrical specification range of 105-135 MHz

42.10.2 Auxiliary Clock Divider

The Auxiliary Clock Output Divider (APSTSCLR<2:0>) bits in the Auxiliary Clock Control register (ACLKCON<10:8>) divide the auxiliary clock, which allow a lower frequency to be chosen. These bits allow for eight postscaler settings, from 1:1 to 1:256, as shown in Table 42-7.

Table 42-7: Auxiliary Clock Output Divider Settings

APSTSCLR<2:0> Bit Value	Auxiliary Oscillator Setting
111	Divide by 1
110	Divide by 2
101	Divide by 4
100	Divide by 8
011	Divide by 16
010	Divide by 32
001	Divide by 64
000	Divide by 256 (default setting)

42.11 FAIL-SAFE CLOCK MONITOR (FSCM)

The Fail-Safe Clock Monitor (FSCM) allows the device to continue to operate in the event of an oscillator failure. The FSCM function is enabled by programming the Clock Switching Mode Configuration bits (FCKSM<1:0>) in the Oscillator Configuration register (FOSC<7:6>) at the time of device programming. When the FSCM is enabled (FCKSM = 00), the LPRC internal oscillator will run at all times except during Sleep mode.

The FSCM monitors the system clock. If it does not detect a system clock within a specific period of time (typically 2 ms, maximum 4 ms), it generates a clock failure trap and switches the system clock to the FRC oscillator. The user application then has the option to either attempt to restart the oscillator or execute a controlled shutdown.

Note: The FSCM does not wake-up the device if the clock fails while the device is in Sleep mode.

The FSCM takes the following actions when it switches to the FRC oscillator:

- The Current Oscillator Selection bits ,COSCON<2:0> (OSCCON<14:12>), are loaded with '000' (Internal FRC).
- The Clock Fail Detect bit, CF (OSCCON<3>), is set to indicate the clock failure.
- The Oscillator Switch Enable control bit, OSWEN (OSCCON<0>), is cleared to cancel any pending clock switches.

42.11.1 FSCM Delay

The FSCM monitors the system clock for activity after the system clock is ready and the nominal delay (TFSCM) has elapsed.

The FSCM delay (TFSCM) is applied when the FSCM is enabled and the POSC or SOSC is selected as the system clock.

Note: Please refer to the "Electrical Characteristics" section of the specific device data sheet for TFSCM values.

Refer to **Section 8. "Reset"** (DS70192) for additional information. Check for the most recent documentation on the Microchip web site at www.microchip.com.

42.11.2 FSCM and WDT

The FSCM and WDT use the LPRC oscillator as their time base. In the event of a clock failure, the WDT is unaffected and continues to run on the LPRC.

42.12 CLOCK SWITCHING

Clock switching can be initiated as a result of a hardware event or a software request. Typical scenario includes:

- Two-Speed Start-up sequence on a POR, which initially uses the internal FRC oscillator for quick start-up, and then automatically switches to the selected clock source when the clock is ready.
- Fail-Safe Clock Monitor automatically switches to Internal FRC Oscillator on a clock failure.
- User application software requests clock switching by setting the OSWEN bit (OSCCON<0>), causing the hardware to switch to the clock source selected by the NOSC bits (OSCCON<10:8>) when the clock is ready.

In each of these cases, the clock switch event assures that the proper make-before-break sequence is executed. That is, the new clock source must be ready before the old clock is deactivated and code must continue to execute as clock switching occurs.

With few limitations, applications are free to switch between any of the four clock sources (POSC, SOSC, FRC, and LPRC) that are under software control at any time. To limit the possible side effects that could result from this flexibility, dsPIC33F devices have a safeguard lock built into the switch process. That is, the OSCCON register is write-protected during clock switching.

42.12.1 Enabling Clock Switching

The Clock Switching Mode Configuration bits (FCKSM<1:0>) in the Oscillator Configuration register (FOSC<7:6>) must be programmed to enable clock switching and the Fail Safe Clock Monitor (see Table 42-8).

Table 42-8: Configurable Clock Switching Modes

FCKSM<1:0> Values	Clock Switching Configuration	FSCM Configuration
1x	Disabled	Disabled
01	Enabled	Disabled
00	Enabled	Enabled

The first bit determines if clock switching is enabled ('0') or disabled ('1'). The second bit determines if the FSCM is enabled ('0') or disabled ('1'). FSCM can only be enabled if clock switching is also enabled. If clock switching is disabled ('1'), the value of the second bit is irrelevant.

42.12.2 Clock Switch Sequence

The recommended process for a clock switch is as follows:

1. Read the COSC bits (OSCCON<14:12>) to determine the current oscillator source (if this information is relevant to the application).
2. Execute the unlock sequence that allows a write to the high byte of the OSCCON register.
3. Write the appropriate value to the NOSC control bits (OSCCON<10:8>) for the new oscillator source.
4. Execute the unlock sequence that allows a write to the low byte of the OSCCON register.
5. Set the OSWEN bit (OSCCON<0>) to initiate the oscillator switch.

After the above steps are completed, the clock switch logic performs the following steps:

1. The clock switching hardware compares the OSCCON<COSC> status bits with the new value of the NOSC control bit (OSCCON<10:8>). If they are the same, the clock switch is a redundant operation. In this case, the OSWEN bit (OSCCON<0>) is cleared automatically and the clock switch is aborted.
2. If a valid clock switch has been initiated, the PLL Lock (OSCCON<5>), and Clock Fail status bits (OSCCON<3>) are cleared.
3. The new oscillator is turned on by the hardware (if it is not currently running). If a crystal oscillator (POSC or SOSC) must be turned on, the hardware waits for TOSCD until the crystal starts oscillating and TOST expires. If the new source uses the PLL, the hardware waits until a PLL lock is detected (OSCCON<5> = 1).
4. The hardware waits for the new clock source to stabilize and then performs the clock switch.
5. The hardware clears the OSWEN bit (OSCCON<0>) to indicate a successful clock transition. In addition, the NOSC bit (OSCCON<10:8>) values are transferred to the COSC status bits (OSCCON<14:12>).
6. The old clock source is turned off at this time, with the exception of the LPRC Oscillator (if the WDT or FSCM are enabled) or the Sosc (if the SOSSEN bit remains set). The timing of the transition between clock sources is as shown in Figure 42-9.

Note 1: Clock switching between XT, HS, and EC Primary Oscillator modes is not possible without reprogramming the device.

2: Direct clock switching between PLL modes is not possible. For example, clock switching should not occur between the POSC with PLL, and Internal FRC Oscillator with PLL.

3: Setting the CLKLOCK bit (OSCCON<7>) prevents clock switching when clock switching is enabled and fail-safe clock monitoring is disabled by the FCKSM Configuration bits (FOSC<7:6> = 01). The OSCCON<7> bit cannot be cleared when it has been set by software. It clears on a POR.

4: The processor continues to execute code throughout the clock switching sequence. Timing sensitive code should not be executed during this time.

Figure 42-9: Clock Transition Timing Diagram

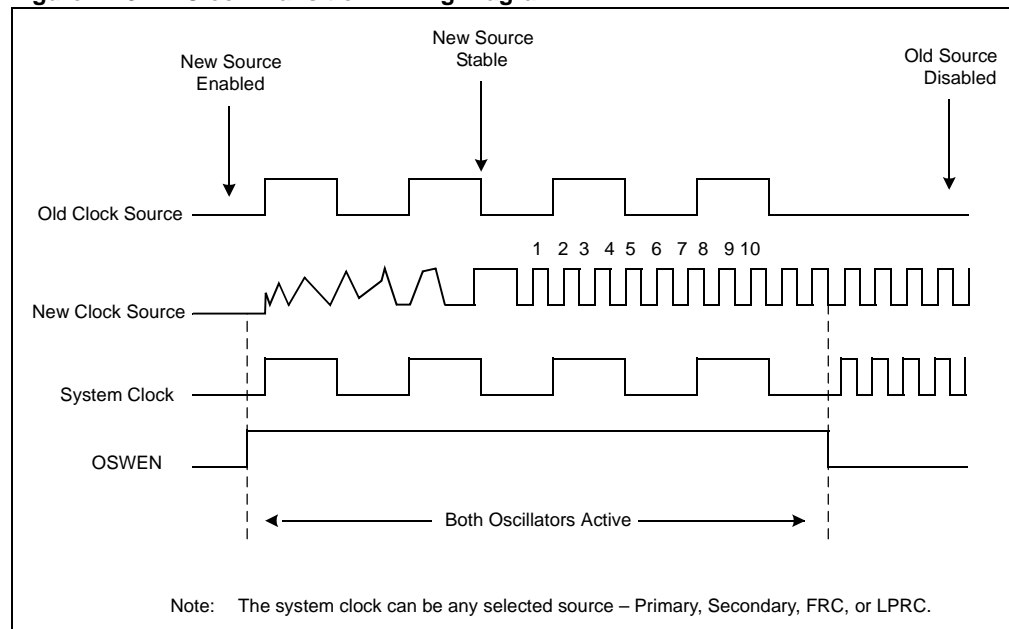

A recommended code sequence for a clock switch includes the following actions:

1. Disable interrupts during the OSCCON register unlock and write sequence.
2. Execute the unlock sequence for the OSCCON high byte, in two back-to-back instructions:
 - Write 0x0078 to OSCCON<15:8>
 - Write 0x009A to OSCCON<15:8>
3. In the instruction immediately following the unlock sequence, write the new oscillator source to the NOSC control bits (OSCCON<10:8>).
4. Execute the unlock sequence for the OSCCON low byte in two, back-to-back instructions:
 - Write 0x0046 to OSCCON<7:0>
 - Write 0x0057 to OSCCON<7:0>
5. In the instruction immediately following the unlock sequence, set the OSWEN bit (OSCCON<0>).
6. Continue to execute code that is not clock-sensitive (optional).
7. Check to see if OSCCON<0> is '0'. If it is, the switch was successful.

Note: MPLAB® C Compiler for dsPIC DSCs provides the following built-in C language functions for unlocking the OSCCON register:

```
__builtin_write_OSCCONL(value)  
__builtin_write_OSCCONH(value)
```

See MPLAB C Compiler Help for more information.

Example 42-4 illustrates the code sequence for unlocking the OSCCON register and switching from FRC with PLL clock to the LPRC clock source.

Example 42-4: Code Example for Clock Switching

```
;Place the New Oscillator Selection (NOSC=0b101) in W0  
MOV #0x15,WREG  
  
;OSCCONH (high byte) Unlock Sequence  
MOV #OSCCONH, w1  
MOV #0x78, w2  
MOV #0x9A, w3  
MOV.B w2, [w1] ; Write 0x0078  
MOV.B w3, [w1] ; Write 0x009A  
  
;Set New Oscillator Selection  
MOV.B WREG, OSCCONH  
  
; Place 0x01 in W0 for setting clock switch enabled bit  
MOV #0x01, w0  
  
;OSCCONL (low byte) Unlock Sequence  
MOV #OSCCONL, w1  
MOV #0x46, w2  
MOV #0x57, w3  
MOV.B w2, [w1] ; Write 0x0046  
MOV.B w3, [w1] ; Write 0x0057  
  
; Enable Clock Switch  
MOV.B w0, [w1] ; Request Clock Switching by Setting OSWEN bit  
wait:  
btsc OSCCONL,#OSWEN  
bra wait
```

42.12.3 Clock Switching Consideration

When you incorporate clock switching into an application, issues to keep in mind when designing your code include:

- The OSCCON unlock sequence is extremely timing critical. The OSCCON register byte is only writable for one instruction cycle following the sequence. Some high-level languages, such as C, may not preserve the timing-sensitive sequence of instructions when compiled. When clock switching is required for an application written in a high-level language, it is best to create the routine in assembler and link it to the application, calling it as a function, when it is required.
- If the destination clock source is a crystal oscillator, the clock switch time will be dominated by the oscillator start-up time.
- If the new clock source does not start, or is not present, clock switching hardware will continue to run from the current clock source. Your software can detect this situation because the OSWEN bit (OSCCON<0>) remains set indefinitely.
- If the new clock source uses the PLL, a clock switch will not occur until lock has been achieved. Your software can detect a loss of PLL lock because the LOCK bit (OSCCON<5>) is cleared and the OSWEN bit (OSCCON<0>) is set.
- Switching to a low-frequency clock source will result in slow device operation.

42.12.4 Aborting a Clock Switch

If a clock switch does not complete, the clock switch logic can be Reset by clearing the OSWEN bit (OSCCON<0>). When OSWEN is cleared, the clock switch process is aborted, the Oscillator Start Timer (if applicable) is stopped and reset, and the PLL (if applicable) is stopped.

Typical assembly code for aborting a clock switch is shown in Example 42-5. A clock switch procedure can be aborted at any time. A clock switch that is already in progress can also be aborted by performing a second clock switch.

Example 42-5: Aborting a Clock Switch

```
MOV    #OSCCON,W1    ; Pointer to OSCCON
MOV.b  #0x46,W2      ; First unlock code
MOV.b  #0x57,W3      ; second unlock code
MOV.b  W2, [W1]      ; Write first unlock code
MOV.b  W3, [W1]      ; Write second unlock code
BCLR   OSCCON,#OSWEN ; ABORT the switch
```

42.12.5 Entering Sleep Mode During a Clock Switch

If the device enters Sleep mode during a clock switch operation, the clock switch operation is aborted. The processor keeps the old clock selection, and the OSWEN bit is cleared. The PWRSAV instruction is then executed normally.

It is particularly useful to perform a clock switch to the internal FRC oscillator before entering Sleep mode, as this will ensure fast wake-up from Sleep.

42.13 TWO-SPEED START-UP

The Internal External Start-up Option Configuration bit (IESO) in the Oscillator Source Selection register (FOSCSEL<7>) specifies whether to start the device with a user application-selected oscillator source or to initially start with the internal FRC and then automatically switch to the user application-selected oscillator. If this bit is set to '1', the device will always power up on the Internal FRC oscillator, regardless of the other oscillator source settings (FOSCSEL<2:0>). The device then automatically switches to the specified oscillator, when it is ready.

Unless FSCM is enabled, the FRC oscillator is automatically turned off immediately after the clock switch is completed. The Two-Speed Start-up option is a faster way to get the device up and running and works independently of the state of the FCKSM Configuration bits (FOSC<7:6>).

Two-Speed Start-up is particularly useful when an external oscillator is selected by the FOSCSEL Configuration bits (FOSC<2:0>) and a crystal-based oscillator has a longer start-up time.

As an internal RC oscillator, the FRC clock source is available almost immediately following a POR. With Two-Speed Start-up, the device starts executing code in its default oscillator configuration—FRC. The device continues to operate in this mode until the specified external oscillator source becomes stable, and at the same time it automatically switches to that source.

User code can check which clock source is currently providing the device clocking by checking the status of the COSC bits (OSCCON<14:12>) against the NOSC bits (OSCCON<10:8>). If these two sets of bits match, the clock switch has been completed successfully and the device is running from the intended clock source.

Note: Two-Speed Start-up is redundant if the selected device clock source is FRC.

42.14 REFERENCE CLOCK OUTPUT

The reference clock output provides a clock signal to any remappable pin (RPx). The reference clock can be either the external oscillator or the system clock.

The ROSEL bit in the Reference Oscillator Control (REFOCON) register selects between the external oscillator and the system clock. The RODIV bits in the REFOCON register scale the reference clock to a desired clock output.

Figure 42-1 shows a block diagram for the reference clock. See the REFOCON register (Register 42-8) for the bits associated with the reference clock output. Refer to the specific device data sheet regarding peripheral remapping.

42.15 REGISTER MAPS

Table 42-9 maps the bit functions for the Oscillator Special Function control registers. Table 42-10 maps the bit functions for the Oscillator Configuration registers.

Table 42-9: Oscillator Special Function Control Registers

File Name	Bit 15	Bit 14	Bit 13	Bit 12	Bit 11	Bit 10	Bit 9	Bit 8	Bit 7	Bit 6	Bit 5	Bit 4	Bit 3	Bit 2	Bit 1	Bit 0	All Resets
OSCCON	—	COSC<2:0>			—	NOSC<2:0>			CLKLOCK	IOLOCK ⁽²⁾	LOCK	—	CF	—	—	OSWEN	0000 ⁽¹⁾
CLKDIV	ROI	DOZE<2:0>			DOZEN	FRCDIV<2:0>			PLLPOST<1:0>			PLLPRE<4:0>					3040
PLLFBD	—	—	—	—	—	—	—	PLLDIV<8:0>									0030
OSCTUN	—	—	—	—	—	—	—	—	—	—	TUN<5:0>						0000
REFOCON	ROON	—	ROSSLP	ROSEL	RODIV<3:0>				—	—	—	—	—	—	—	—	0000
ACLKCON	ENAPLL	APLCK	SELACLK	—	—	APSTSCLR<2:0>			ASRCSEL	FRCSEL	—	—	—	—	—	—	0000

Legend: x = unknown value on Reset, — = unimplemented, read as '0'. Reset values are shown in hexadecimal.

Note 1: OSCCON register Reset values dependent on the FOSCSSEL Configuration bits and by type of Reset.

Note 2: The IOLOCK bit is not available on all dsPIC33F devices. Refer to the specific device data sheet for more information.

Table 42-10: Oscillator Configuration Registers

File Name	Bit 15	Bit 14	Bit 13	Bit 12	Bit 11	Bit 10	Bit 9	Bit 8	Bit 7	Bit 6	Bit 5	Bit 4	Bit 3	Bit 2	Bit 1	Bit 0	All Resets
FOSCSSEL	—	—	—	—	—	—	—	—	IESO	—	—	—	—	FNOSC<2:0>			xxxxx ⁽²⁾
FOSC	—	—	—	—	—	—	—	—	FCKSM<1:0>	IOL1WAY ⁽¹⁾	—	—	OSCIofnc	POSCMD<1:0>			xxxxx

Legend: x = unknown value on Reset, — = unimplemented, read as '0'. Reset values are shown in hexadecimal.

Note 1: The IOL1WAY bit is not available on all dsPIC33F devices. Refer to the specific device data sheet for more information.

Note 2: Configuration bits are programmed during device programming and it retains the programmed values on reset.

42.16 RELATED APPLICATION NOTES

This section lists application notes that pertain to this section of the manual. These application notes may not be written specifically for the dsPIC33F Product Family, but the concepts are pertinent and could be used with modification and possible limitations. The current application notes related to the Oscillator (Part IV) module include:

Title	Application Note #
PIC [®] Microcontroller Oscillator Design Guide	AN588
Low-Power Design using PIC [®] Microcontrollers	AN606
Crystal Oscillator Basics and Crystal Selection for rfPIC [®] and PIC [®] Devices	AN826

Note: Please visit the Microchip web site (www.microchip.com) for additional Application Notes and code examples for the dsPIC33F family of devices.

42.17 REVISION HISTORY

Revision A (September 2007)

This is the initial release of this document.

Revision B (August 2008)

This revision incorporates the following updates:

- Figures:
 - Updated the label PLLCLK with Fvco⁽¹⁾ and added new labels in Figure 42-1.
- Notes:
 - Added Note 1 to refer the Fvco values (see Figure 42-1).
 - Added a note for configuring the auxiliary clock (see **42.10.1 “Enabling the Auxiliary PLL”**).
 - Added a note on configuration bits in Oscillator Configuration Registers table (see Note 2 in Table 42-10).
- Registers:
 - Removed incorrect legend in FOSC: Oscillator Configuration Register (see Register 42-2) and CLKDIV: Clock Divisor Register (see Register 42-4).
 - Performed the following corrections in OSCCON: Oscillator Control Register (see Register 42-3):
 - Updated the incorrect Read/Write state for bit 9, bit 10, bit 12, bit 13, and bit 14.
 - Updated the incorrect bit description for COSC bit (bit 14-12) and NOSC bit (bit 10-8) as Reserved.
 - Updated bit 1 and 2 as bit 2-1: Unimplemented: Read as '0'.
 - The tuned frequencies for bit 5-0 in the OSCTUN: FRC Oscillator Tuning Register have been corrected (see Register 42-6).
 - Performed the following updates in ACLKCON: Auxiliary Clock Control Register (see Register 42-7):
 - Updated the bit descriptions for bit 6 and bit 7.
 - Updated the values of the bit field for bit 10-8.
 - Updated the term PLL as Fvco in bit 13.
- Sections:
 - All references to the Secondary Oscillator have been removed
 - Updated the last sentence in bullet 3 under the clock switch logic section as “If the primary oscillator must be turned on, the hardware waits until a PLL lock is detected (OSCCON<5> = 1)” in **42.12.2 “Clock Switch Sequence”**:
- Tables:
 - The All Resets column has been added in the Oscillator Configuration Registers table (see Table 42-10).
- Additional minor corrections such as language and formatting updates are incorporated throughout the document.

Revision C (November 2009)

This revision incorporates the following content updates:

- Added a note with information to customers for utilizing family reference manual sections and data sheets as a joint reference (see note above **42.1 “Introduction”**).
- Changed all occurrences of OSCI to OSC1 and OSCO to OSC2
- Added information on the Secondary Oscillator to the following locations in their order of appearance:
 - Updated the logic in Figure 42-1 and added Note 3
 - Second bullet list item in **42.2 “CPU Clocking”**
 - Added S4 oscillator source and Note 3 to Table 42-1
 - Updated FNOSC<2:0> = 100 from “Reserved” to “Secondary Oscillator (Sosc)” and added Note 1 to Register
 - Updated COSC<2:0> = 100 and NOSC<2:0> = 100 from “Reserved” to “Secondary Oscillator (Sosc)” and added Note 2 to Register 42-3
 - Updated the second paragraph of **42.5.1 “Oscillator Start-up Time”**
 - Added 42.8
 - Updated the second paragraph of **42.11.1 “FSCM Delay”**
 - Updated the third paragraph of **42.12 “Clock Switching”**
 - Updated Step 3 and Step 6 of the second procedure in **42.12.2 “Clock Switch Sequence”**
 - Updated the Note in Figure 42-9
- Registers:
 - Added Note 1 to OSCCON: Oscillator Control Register (Register 42-3)
 - Added Note 2 to CLKDIV: Clock Divisor Register (Register 42-4)
 - Added Note 1 to REFOCON: Reference Oscillator Control Register (Register 42-8)
 - Updated the SELACLK bit description for value ‘0’ (see Register 42-7)
- Figures:
 - Updated Figure 42-1
 - Updated Figure 42-3
- Added Note 2 regarding FRC Oscillator Tuning (TUN<5:0>) bits to Internal FRC Oscillator section (**42.6 “Internal FRC Oscillator”**)
- Added Note 2 in the shaded note box in **42.10.1 “Enabling the Auxiliary PLL”**
- Updated code examples (Example 42-1, Example 42-2 and Example 42-4)
- Additional minor corrections such as language and formatting updates have been incorporated throughout the document.

NOTES: