



---

---

## Section 19. Inter-Integrated Circuit™ (I<sup>2</sup>C™)

---

---

### HIGHLIGHTS

This section of the manual contains the following major topics:

19.1 Overview .....	19-2
19.2 I <sup>2</sup> C-Bus Characteristics.....	19-4
19.3 Control and Status Registers .....	19-7
19.4 Enabling I <sup>2</sup> C Operation .....	19-13
19.5 Communicating as a Master in a Single-Master Environment .....	19-15
19.6 Communicating as a Master in a Multi-Master Environment .....	19-28
19.7 Communicating as a Slave .....	19-31
19.8 Connection Considerations for I <sup>2</sup> C-Bus .....	19-46
19.9 Module Operation During PWRSAV Instruction .....	19-47
19.10 Peripheral Module Disable (PMD) Registers .....	19-47
19.11 Effects of a Reset.....	19-47
19.12 Register Maps.....	19-48
19.13 Design Tips .....	19-49
19.14 Related Application Notes.....	19-50
19.15 Revision History .....	19-51

## 19.1 OVERVIEW

The Inter-Integrated Circuit (I<sup>2</sup>C) module is a serial interface useful for communicating with other peripheral or microcontroller devices. These peripheral devices may be serial EEPROMs, display drivers, A/D converters, etc.

The I<sup>2</sup>C module can operate in any of the following I<sup>2</sup>C systems:

- As a slave device
- As a master device in a single-master system (slave may also be active)
- As a master/slave device in a multi-master system (bus collision detection and arbitration available)

The I<sup>2</sup>C module contains independent I<sup>2</sup>C master logic and I<sup>2</sup>C slave logic, each generating interrupts based on their events. In multi-master systems, the software is simply partitioned into master controller and slave controller.

When the I<sup>2</sup>C master logic is active, the slave logic also remains active, detecting the state of the bus and potentially receiving messages from itself in a single-master system or from other masters in a multi-master system. No messages are lost during multi-master bus arbitration.

In a multi-master system, bus collision conflicts with other masters in the system are detected, and the module provides a method to terminate and then restart the message.

The I<sup>2</sup>C module contains a Baud Rate Generator (BRG). The I<sup>2</sup>C Baud Rate Generator does not consume other timer resources in the device.

Key features of the I<sup>2</sup>C module include the following:

- Independent master and slave logic
- Multi-master support which prevents message losses in arbitration
- Detects 7-bit and 10-bit device addresses with configurable address masking in Slave mode
- Detects general call addresses as defined in the I<sup>2</sup>C protocol
- Bus Repeater mode, allowing the module to accept all messages as a slave regardless of the address
- Automatic SCLx clock stretching provides delays for the processor to respond to a slave data request
- Supports 100 kHz and 400 kHz bus specifications
- Supports the Intelligent Platform Management Interface (IPMI) standard

Figure 19-1 shows the I<sup>2</sup>C module block diagram.

Figure 19-1: I<sup>2</sup>C™ Block Diagram

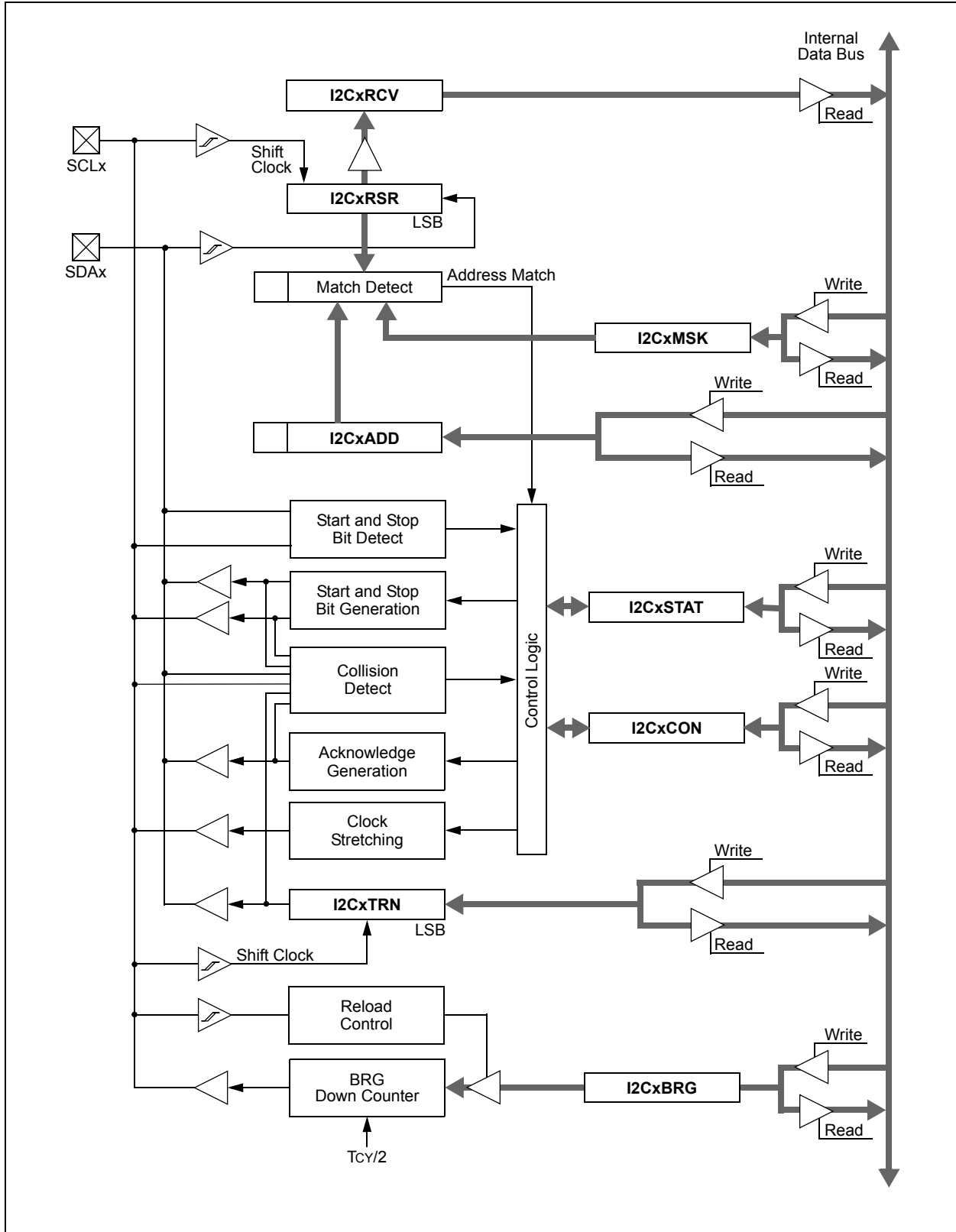

## 19.2 I<sup>2</sup>C-BUS CHARACTERISTICS

The I<sup>2</sup>C-bus is a two-wire serial interface. Figure 19-2 shows a schematic of an I<sup>2</sup>C connection between a PIC24H device and a 24LC256 I<sup>2</sup>C serial EEPROM, which is a typical example for any I<sup>2</sup>C interface.

The interface uses a comprehensive protocol to ensure reliable transmission and reception of data. When communicating, one device acts as the “master” and it initiates transfer on the bus and generates the clock signals to permit that transfer, while the other device(s) acts as the ‘slave’ responding to the transfer. The clock line, SCLx, is output from the master and input to the slave, although occasionally the slave drives the SCLx line. The data line, SDAx, may be output and input from both the master and slave.

Because the SDAx and SCLx lines are bidirectional, the output stages of the devices driving the SDAx and SCLx lines must have an open drain in order to perform the wired AND function of the bus. External pull-up resistors are used to ensure a high level when no device is pulling the line down.

In the I<sup>2</sup>C interface protocol, each device has an address. When a master wishes to initiate a data transfer, it first transmits the address of the device that it wants to ‘talk’ to. All devices ‘listen’ to see if this is their address. Within this address, bit 0 specifies whether the master wants to read from or write to the slave device. The master and slave are always in opposite modes (transmitter/receiver) of operation during a data transfer. That is, they can be thought of as operating in either of the following two relations:

- Master-Transmitter and Slave-Receiver
- Slave-Transmitter and Master-Receiver

In both cases, the master originates the SCLx clock signal.

**Figure 19-2: Typical I<sup>2</sup>C™ Interconnection Block Diagram**

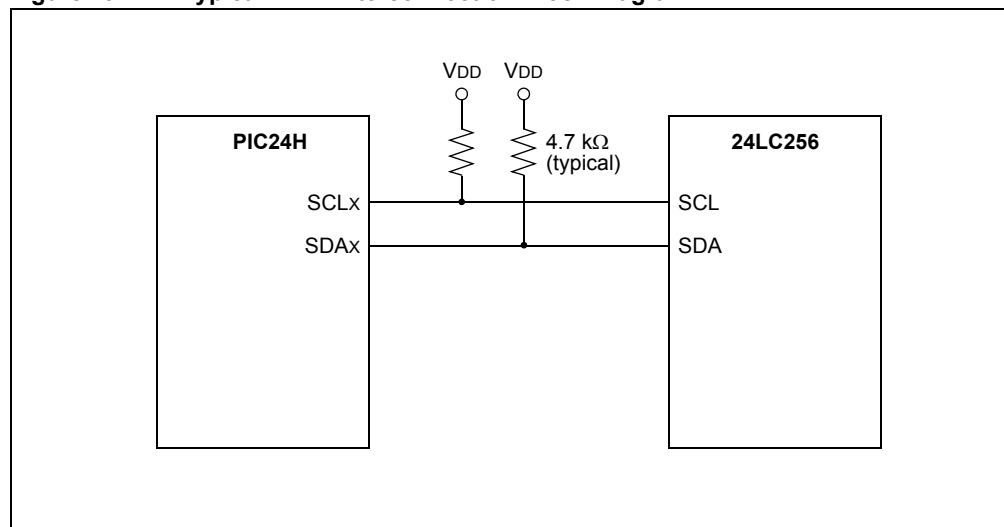

## 19.2.1 Bus Protocol

The following I<sup>2</sup>C-bus protocol has been defined:

- Data transfer may be initiated only when the bus is not busy.
- During data transfer, the data line must remain stable whenever the SCLx clock line is high. Changes in the data line while the SCLx clock line is high will be interpreted as a Start or Stop condition.

Accordingly, the bus conditions shown in Figure 19-3 have been defined.

**Figure 19-3: I<sup>2</sup>C™-Bus Protocol States**

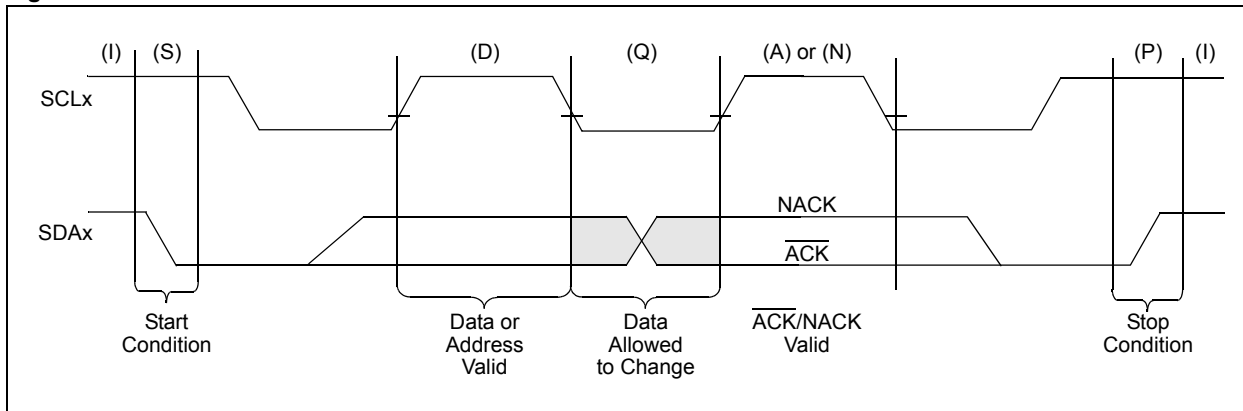

### 19.2.1.1 START DATA TRANSFER (S)

After a bus Idle state, a high-to-low transition of the SDAx line while the clock (SCLx) is high determines a Start condition. All data transfers must be preceded by a Start condition.

### 19.2.1.2 STOP DATA TRANSFER (P)

A low-to-high transition of the SDAx line while the clock (SCLx) is high determines a Stop condition. All data transfers must end with a Stop condition.

### 19.2.1.3 REPEATED START (R)

After a wait state, a high-to-low transition of the SDAx line while the clock (SCLx) is high determines a Repeated Start condition. Repeated Starts allow a master to change bus direction or addressed slave device without relinquishing control of the bus.

### 19.2.1.4 DATA VALID (D)

The state of the SDAx line represents valid data when, after a Start condition, the SDAx line is stable for the duration of the high period of the clock signal. There is one bit of data per SCLx clock.

### 19.2.1.5 ACKNOWLEDGE (A) OR NOT ACKNOWLEDGE (N)

All data byte transmissions must be Acknowledged ( $\overline{\text{ACK}}$ ) or Not Acknowledged (NACK) by the receiver. The receiver will pull the SDAx line low for an  $\overline{\text{ACK}}$  or release the SDAx line for a NACK. The Acknowledge is a one-bit period using one SCLx clock.

### 19.2.1.6 WAIT/DATA INVALID (Q)

The data on the line must be changed during the low period of the clock signal. Devices may also stretch the clock low time by asserting a low on the SCLx line, causing a wait on the bus.

### 19.2.1.7 BUS IDLE (I)

Both data and clock lines remain high at those times after a Stop condition and before a Start condition.

## 19.2.2 Message Protocol

A typical I<sup>2</sup>C message is shown in Figure 19-4. In this example, the message will read a specified byte from a 24LC256 I<sup>2</sup>C serial EEPROM. The PIC24H device will act as the master and the 24LC256 device will act as the slave.

Figure 19-4 indicates the data as driven by the master device and the data as driven by the slave device, taking into account that the combined SDAx line is a wired AND of the master and slave data. The master device controls and sequences the protocol. The slave device will only drive the bus at specifically determined times.

**Figure 19-4: A Typical I<sup>2</sup>C™ Message: Read of Serial EEPROM (Random Address Mode)**

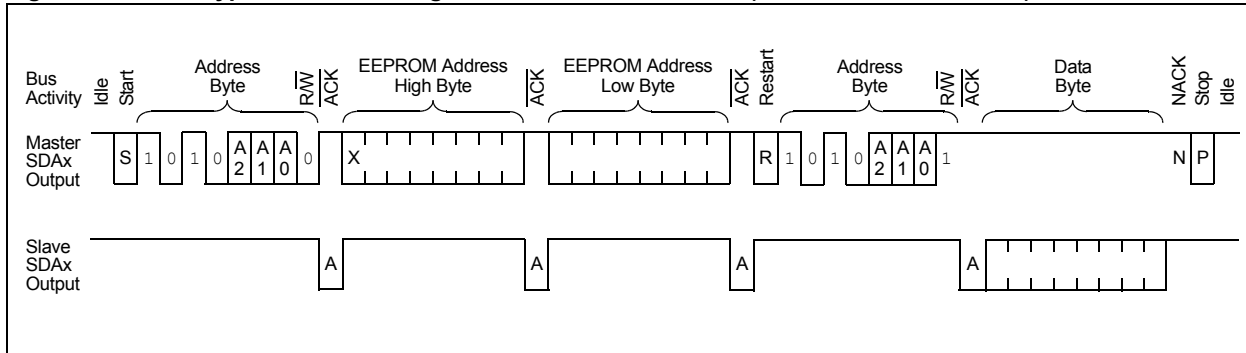

### 19.2.2.1 START MESSAGE

Each message is initiated with a 'Start' condition and terminated with a 'Stop' condition. The number of data bytes transferred between the Start and Stop conditions is determined by the master device. As defined by the system protocol, the bytes of the message may have special meaning, such as "device address byte" or "data byte".

### 19.2.2.2 ADDRESS SLAVE

In Figure 19-4, the first byte is the device address byte, which must be the first part of any I<sup>2</sup>C message. It contains a device address and a R/W status bit. Refer to **Appendix A: "I<sup>2</sup>C™ Overview"** in the *dsPIC30F Family Reference Manual* (DS70074) for additional information on address byte formats (check the Microchip web site for availability: [www.microchip.com](http://www.microchip.com)). Note that R/W = 0 for this first address byte, indicating that the master will be a transmitter and the slave will be a receiver.

### 19.2.2.3 SLAVE ACKNOWLEDGE

The receiving device is obliged to generate an Acknowledge signal,  $\overline{\text{ACK}}$ , after the reception of each byte. The master device must generate an extra SCLx clock, which is associated with this Acknowledge bit.

### 19.2.2.4 MASTER TRANSMIT

The next two bytes, sent by the master to the slave, are data bytes containing the location of the requested EEPROM data byte. The slave must Acknowledge each of the data bytes.

### 19.2.2.5 REPEATED START

At this point, the slave EEPROM has the address information necessary to return the requested data byte to the master. However, the R/W status bit from the first device address byte specified master transmission and slave reception. The bus must be turned in the other direction for the slave to send data to the master.

To perform this function without ending the message, the master sends a 'Repeated Start'. The Repeated Start is followed with a device address byte containing the same device address as before and with the R/W = 1 to indicate slave transmission and master reception.

## 19.2.2.6 SLAVE REPLY

Now the slave transmits the data byte by driving the SDAx line, while the master continues to originate clocks but releases its SDAx drive.

## 19.2.2.7 MASTER ACKNOWLEDGE

During reads, a master must terminate data requests to the slave by Not Acknowledging (generating a “NACK”) on the last byte of the message.

## 19.2.2.8 STOP MESSAGE

The master sends a Stop to terminate the message and return the bus to an Idle state.

## 19.3 CONTROL AND STATUS REGISTERS

The I<sup>2</sup>C module has seven registers for operation that are accessible by the user application. All registers are accessible in either Byte or Word mode. The registers are as follows:

- Control Register (I2CxCON): This register (Register 19-1) allows control of the module's operation.
- Status Register (I2CxSTAT): This register (Register 19-2) contains status flags indicating the module's state during operation.
- Address Mask Register (I2CxMSK): This register (Register 19-3) designates which bit positions in the I2CxADD register can be ignored, which allows for multiple address support.
- Receive Buffer Register (I2CxRCV): This is the buffer register from which data bytes can be read. The I2CxRCV register is a read-only register.
- Transmit Register (I2CxTRN): This is the transmit register. Bytes are written to this register during a transmit operation. The I2CxTRN register is a read/write register.
- Address Register (I2CxADD): This register holds the slave device address.
- Baud Rate Generator Reload Register (I2CxBRG): Holds the Baud Rate Generator reload value for the I<sup>2</sup>C module Baud Rate Generator.

I2CxTRN is the register to which transmit data is written. This register is used when the module operates as a master transmitting data to the slave, or when it operates as a slave sending reply data to the master. As the message progresses, the I2CxTRN register shifts out the individual bits. Because of this, the I2CxTRN register cannot be written to unless the bus is Idle. The I2CxTRN register can be reloaded while the current data is transmitting.

Data being received by either the master or the slave is shifted into a non-accessible shift register, I2CxRSR. When a complete byte is received, the byte transfers to the I2CxRCV register. In receive operations, the I2CxRSR and I2CxRCV registers create a double-buffered receiver. This allows reception of the next byte to begin before reading the current byte of received data.

If the module receives another complete byte before the software reads the previous byte from the I2CxRCV register, a receiver overflow occurs and sets the I2COV bit (I2CxSTAT<6>). The byte in the I2CxRSR register is lost. Further reception and clock stretching are disabled until the module sees a Start/Repeated, Start/Stop condition on the bus. If the I2COV flag has been cleared, reception can proceed normally. If the I2COV flag is not cleared, the module will receive the next byte correctly, but will send a NACK. It will then be unable to receive further bytes or stretch the clock until it detects a Start/Repeated, Start/Stop condition.

The I2CxADD register holds the slave device address. In 10-bit Addressing mode, all bits are relevant. In 7-bit Addressing mode, only the I2CxADD<6:0> bits are relevant. Note that the I2CxADD<6:0> bits correspond to the upper seven bits in the address byte; the Read/Write bit is not included in the value in this register. The A10M bit (I2CxCON<10>) specifies the expected mode of the slave address. By using the I2CxMSK register with the I2CxADD register in either Slave Addressing mode, one or more bit positions can be removed from exact address matching, allowing the module in Slave mode to respond to multiple addresses.

# PIC24H Family Reference Manual

**Register 19-1: I2CxCON: I2Cx Control Register**

R/W-0	U-0	R/W-0	R/W-1, HC	R/W-0	R/W-0	R/W-0	R/W-0
I2CEN	—	I2CSIDL	SCLREL	IPMIEN	A10M	DISSLW	SMEN
bit 15							bit 8

R/W-0	R/W-0	R/W-0	R/W-0, HC	R/W-0, HC	R/W-0, HC	R/W-0, HC	R/W-0, HC
GCEN	STREN	ACKDT	ACKEN	RCEN	PEN	RSEN	SEN
bit 7							bit 0

<b>Legend:</b>	U = Unimplemented bit, read as '0'
R = Readable bit	W = Writable bit
-n = Value at Reset	'1' = Bit is set
	HS = Set in Hardware
	HC = Cleared in Hardware
	'0' = Bit is cleared
	x = Bit is unknown

- bit 15      **I2CEN:** I2Cx Enable bit  
 1 = Enables the I2Cx module and configures the SDAx and SCLx pins as serial port pins  
 0 = Disables the I2Cx module; all I<sup>2</sup>C pins are controlled by port functions
- bit 14      **Unimplemented:** Read as '0'
- bit 13      **I2CSIDL:** Stop in Idle Mode bit  
 1 = Discontinue module operation when device enters Idle mode  
 0 = Continue module operation in Idle mode
- bit 12      **SCLREL:** SCLx Release Control bit (when operating as I<sup>2</sup>C slave)  
 1 = Release SCLx clock  
 0 = Hold SCLx clock low (clock stretch)  
If STREN = 1:  
 Bit is R/W (i.e., software may write '0' to initiate stretch and write '1' to release clock). Hardware clear at beginning of slave transmission and at end of slave reception.  
If STREN = 0:  
 Bit is R/S (i.e., software may only write '1' to release clock). Hardware clear at beginning of slave transmission.
- bit 11      **IPMIEN:** Intelligent Platform Management Interface (IPMI) Enable bit  
 1 = IPMI Support mode is enabled; all addresses Acknowledged  
 0 = IPMI Support mode disabled
- bit 10      **A10M:** 10-Bit Slave Address bit  
 1 = I2CxADD register is a 10-bit slave address  
 0 = I2CxADD register is a 7-bit slave address
- bit 9        **DISSLW:** Disable Slew Rate Control bit  
 1 = Slew rate control disabled  
 0 = Slew rate control enabled
- bit 8        **SMEN:** SMBus Input Levels bit  
 1 = Enable I/O pin thresholds compliant with SMBus specification  
 0 = Disable SMBus input thresholds
- bit 7        **GCEN:** General Call Enable bit (when operating as I<sup>2</sup>C slave)  
 1 = Enable interrupt when a general call address is received in the I2CxRSR register (module is enabled for reception)  
 0 = General call address disabled
- bit 6        **STREN:** SCLx Clock Stretch Enable bit (I<sup>2</sup>C Slave mode only; used in conjunction with SCLREL bit)  
 1 = Enable software or receive clock stretching  
 0 = Disable software or receive clock stretching



## Register 19-1: I2CxCON: I2Cx Control Register (Continued)

- bit 5      **ACKDT:** Acknowledge Data bit (I<sup>2</sup>C Master mode; receive operation only)  
Value that will be transmitted when the software initiates an Acknowledge sequence  
1 = Send  $\overline{\text{NACK}}$  during Acknowledge  
0 = Send  $\overline{\text{ACK}}$  during Acknowledge
- bit 4      **ACKEN:** Acknowledge Sequence Enable bit (I<sup>2</sup>C Master mode receive operation)  
1 = Initiate Acknowledge sequence on SDAx and SCLx pins and transmit ACKDT data bit (hardware clear at end of master Acknowledge sequence)  
0 = Acknowledge sequence not in progress
- bit 3      **RCEN:** Receive Enable bit (I<sup>2</sup>C Master mode)  
1 = Enables Receive mode for I<sup>2</sup>C (hardware clear at end of eighth bit of master receive data byte)  
0 = Receive sequence not in progress
- bit 2      **PEN:** Stop Condition Enable bit (I<sup>2</sup>C Master mode)  
1 = Initiate Stop condition on SDAx and SCLx pins (hardware clear at end of master Stop sequence)  
0 = Stop condition not in progress
- bit 1      **RSEN:** Repeated Start Condition Enable bit (I<sup>2</sup>C Master mode)  
1 = Initiate Repeated Start condition on SDAx and SCLx pins (hardware clear at end of master Repeated Start sequence)  
0 = Repeated Start condition not in progress
- bit 0      **SEN:** Start Condition Enable bit (I<sup>2</sup>C Master mode)  
1 = Initiate Start condition on SDAx and SCLx pins (hardware clear at end of master Start sequence)  
0 = Start condition not in progress

# PIC24H Family Reference Manual

**Register 19-2: I2CxSTAT: I2Cx Status Register**

R-0, HSC	R-0, HSC	U-0	U-0	U-0	R/C-0, HS	R-0, HSC	R-0, HSC
ACKSTAT	TRSTAT	—	—	—	BCL	GCSTAT	ADD10
bit 15						bit 8	

R/C-0, HS	R/C-0, HS	R-0, HSC	R-0, HSC	R-0, HSC	R-0, HSC	R-0, HSC	R-0, HSC
IWCOL	I2COV	D/ $\bar{A}$	P	S	R/ $\bar{W}$	RBF	TBF
bit 7						bit 0	

<b>Legend:</b>				U = Unimplemented bit, read as '0'			
R = Readable bit	C = Clearable bit	HS = Set in Hardware	HSC = Hardware Set/Cleared				
-n = Value at Reset	'1' = Bit is set	'0' = Bit is clear	x = Bit is unknown				

- bit 15      **ACKSTAT:** Acknowledge Status bit  
 1 = NACK received from slave  
 0 = ACK received from slave  
 Hardware set or clear at end of Slave or Master Acknowledge.
- bit 14      **TRSTAT:** Transmit Status bit (I<sup>2</sup>C Master mode transmit operation)  
 1 = Master transmit is in progress (8 bits +  $\bar{A}CK$ )  
 0 = Master transmit is not in progress  
 Hardware set at beginning of master transmission; hardware clear at end of slave Acknowledge.
- bit 13-11   **Unimplemented:** Read as '0'
- bit 10      **BCL:** Master Bus Collision Detect bit  
 1 = A bus collision has been detected during a master operation  
 0 = No collision  
 Hardware set at detection of bus collision.
- bit 9        **GCSTAT:** General Call Status bit  
 1 = General call address was received  
 0 = General call address was not received  
 Hardware set when address matches general call address; hardware clear at Stop detection.
- bit 8        **ADD10:** 10-Bit Address Status bit  
 1 = 10-bit address was matched  
 0 = 10-bit address was not matched  
 Hardware set at match of 2nd byte of matched 10-bit address; hardware clear at Stop detection.
- bit 7        **IWCOL:** Write Collision Detect bit  
 1 = An attempt to write the I2CxTRN register failed because the I<sup>2</sup>C module is busy  
 0 = No collision  
 Hardware set at occurrence of write to I2CxTRN register while busy (cleared by software).
- bit 6        **I2COV:** Receive Overflow Flag bit  
 1 = A byte was received while the I2CxRCV register is still holding the previous byte  
 0 = No overflow  
 Hardware set at attempt to transfer I2CxRSR register to I2CxRCV register (cleared by software).
- bit 5        **D/ $\bar{A}$ :** Data/Address bit (I<sup>2</sup>C Slave mode)  
 1 = Indicates that the last byte received was data  
 0 = Indicates that the last byte received was a device address  
 Hardware clear at device address match; hardware set by reception of the slave byte or is set after the transmission is complete and the TBF flag is cleared.
- bit 4        **P:** Stop bit  
 1 = Indicates that a Stop bit has been detected last  
 0 = Stop bit was not detected last  
 Hardware set or clear when Start, Repeated Start or Stop detected.

## Register 19-2: I2CxSTAT: I2Cx Status Register (Continued)

- bit 3      **S:** Start bit  
1 = Indicates that a Start (or Repeated Start) bit has been detected last  
0 = Start bit was not detected last  
Hardware set or clear when Start, Repeated Start or Stop detected.
- bit 2      **R/W:** Read/Write Information bit (when operating as I<sup>2</sup>C slave)  
1 = Read: data transfer is output from slave  
0 = Write: data transfer is input to slave  
Hardware set or clear after reception of I<sup>2</sup>C device address byte.
- bit 1      **RBF:** Receive Buffer Full Status bit  
1 = Receive complete; I2CxRCV register is full  
0 = Receive not complete; I2CxRCV register is empty  
Hardware set when the I2CxRCV register is written with received byte; hardware clear when software reads the I2CxRCV register.
- bit 0      **TBF:** Transmit Buffer Full Status bit  
1 = Transmit in progress; I2CxTRN register is full  
0 = Transmit complete; I2CxTRN register is empty  
Hardware set when software writes to I2CxTRN register; hardware clear at completion of data transmission.

# PIC24H Family Reference Manual

**Register 19-3: I2CxMSK: I2Cx Slave Mode Address Mask Register**

U-0	U-0	U-0	U-0	U-0	U-0	R/W-0	R/W-0
—	—	—	—	—	—	AMSK9	AMSK8
bit 15						bit 8	

R/W-0	R/W-0	R/W-0	R/W-0	R/W-0	R/W-0	R/W-0	R/W-0
AMSK7	AMSK6	AMSK5	AMSK4	AMSK3	AMSK2	AMSK1	AMSK0
bit 7						bit 0	

**Legend:**

R = Readable bit	W = Writable bit	U = Unimplemented bit, read as '0'
-n = Value at Reset	'1' = Bit is set	'0' = Bit is cleared
		x = Bit is unknown

bit 15-10     **Unimplemented:** Read as '0'

bit 9-0        **AMSKx:** Mask for Address Bit x Select bit

For 10-Bit Address:

1 = Enable masking for bit Ax of incoming message address; bit match not required in this position

0 = Disable masking for bit Ax; bit match required in this position

For 7-Bit Address (I2CxMSK<6:0> only):

1 = Enable masking for bit Ax + 1 of incoming message address; bit match not required in this position

0 = Disable masking for bit Ax + 1; bit match required in this position

## 19.4 ENABLING I<sup>2</sup>C OPERATION

The I<sup>2</sup>C module is enabled by setting the I2CEN (I2CxCON<15>) bit.

The I<sup>2</sup>C module fully implements all master and slave functions. When the module is enabled, the master and slave functions are active simultaneously and will respond according to the software or bus events.

When initially enabled, the module will release the SDAx and SCLx pins, putting the bus into the Idle state. The master functions will remain in the Idle state unless software sets the SEN control bit and data is loaded into the I2CxTRN register. These two actions initiate a master event.

When the master logic is active, the slave logic also remains active. Therefore, the slave functions will begin to monitor the bus. If the slave logic detects a Start event and a valid address on the bus, the slave logic will begin a slave transaction.

### 19.4.1 Enabling I<sup>2</sup>C I/O

Two pins are used for bus operation. These are the SCLx pin, which is the clock, and the SDAx pin, which is the data. When the module is enabled, assuming no other module with higher priority has control, the module will assume control of the SDAx and SCLx pins. The module software need not be concerned with the state of the port I/O of the pins, as the module overrides the port state and direction. At initialization, the pins are tri-stated (released).

### 19.4.2 I<sup>2</sup>C Interrupts

The I<sup>2</sup>C module generates two interrupts. One interrupt, MI2CxIF, is assigned to master events; the other interrupt, SI2CxIF, is assigned to slave events. These interrupts set a corresponding interrupt flag bit and interrupt the software process if the corresponding interrupt enable bit is set and the corresponding interrupt priority is high enough.

The MI2CxIF interrupt is generated on completion of the following master message events:

- Start condition
- Stop condition
- Data transfer byte transmitted/received
- Acknowledge transmit
- Repeated Start
- Detection of a bus collision event

The SI2CxIF interrupt is generated on detection of a message directed to the slave, including the following events:

- Detection of a valid device address (including general call)
- Request to transmit data ( $\overline{\text{ACK}}$ ) or to stop data transmission (NACK)
- Reception of data

## 19.4.3 Setting Baud Rate When Operating as a Bus Master

When operating as an I<sup>2</sup>C master, the module must generate the system SCLx clock. Generally, I<sup>2</sup>C system clocks are specified to be either 100 kHz, 400 kHz or 1 MHz. The system clock rate is specified as the minimum SCLx low time plus the minimum SCLx high time. In most cases, that is defined by two TBRG intervals.

The reload value for the Baud Rate Generator is the I2CxBRG register, as shown in Figure 19-5. When the Baud Rate Generator is loaded with this value, the generator counts down to 0 and stops until another reload has taken place. The generator count is decremented twice per instruction cycle (Tcy). The Baud Rate Generator is reloaded automatically on baud rate restart. For example, if clock synchronization is taking place, the Baud Rate Generator will be reloaded when the SCLx pin is sampled high.

**Note:** I2CxBRG register values of less than 2 are not supported.

To calculate the Baud Rate Generator reload value, use the following equation:

**Equation 19-1: BRG Reload Value Calculation**

$$I2C_{BRG} = \left( \frac{F_{CY}}{F_{SCL}} - \frac{F_{CY}}{10,000,000} \right) - 1$$

**Table 19-1: I<sup>2</sup>C™ Clock Rates**

Required System F <sub>SCL</sub>	F <sub>cy</sub>	I2C <sub>BRG</sub> Decimal	I2C <sub>BRG</sub> Hexadecimal	Actual F <sub>SCL</sub>
100 kHz	40 MHz	395	0x18B	100 kHz
100 kHz	20 MHz	197	0x0C5	100 kHz
100 kHz	10 MHz	98	0x0b2	100 kHz
400 kHz	20 MHz	47	0x02F	400 kHz
400 kHz	10 MHz	23	0x017	400 kHz
400 kHz	5 MHz	11	0x00B	400 kHz
1 MHz	10 MHz	8	0x008	1 MHz

**Note:** Equation 19-1 and Table 19-1 are only guidelines. Due to system-dependant parameters, the actual baud rate may differ slightly. Testing will be needed to confirm that the actual baud rate meets system requirements. Otherwise, the value of I2CxBRG may need to be adjusted.

**Figure 19-5: Baud Rate Generator Block Diagram**

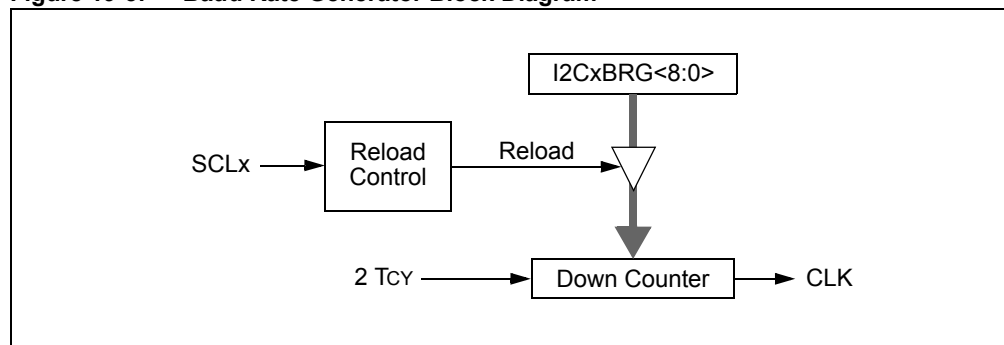

## 19.5 COMMUNICATING AS A MASTER IN A SINGLE-MASTER ENVIRONMENT

The I<sup>2</sup>C module's typical operation in a system is using the I<sup>2</sup>C to communicate with an I<sup>2</sup>C peripheral, such as an I<sup>2</sup>C serial memory. In an I<sup>2</sup>C system, the master controls the sequence of all data communication on the bus. In this example, the PIC24H and its I<sup>2</sup>C module have the role of the single-master in the system. As the single-master, it is responsible for generating the SCLx clock and controlling the message protocol.

In the I<sup>2</sup>C module, the module controls individual portions of the I<sup>2</sup>C message protocol; however, sequencing of the components of the protocol to construct a complete message is a software task.

For example, a typical operation in a single-master environment may be to read a byte from an I<sup>2</sup>C serial EEPROM. This example message is depicted in Figure 19-6.

To accomplish this message, the software will sequence through the following steps.

1. Assert a Start condition on SDAx and SCLx.
2. Send the I<sup>2</sup>C device address byte to the slave with a write indication.
3. Wait for and verify an Acknowledge from the slave.
4. Send the serial memory address high byte to the slave.
5. Wait for and verify an Acknowledge from the slave.
6. Send the serial memory address low byte to the slave.
7. Wait for and verify an Acknowledge from the slave.
8. Assert a Repeated Start condition on SDAx and SCLx.
9. Send the device address byte to the slave with a read indication.
10. Wait for and verify an Acknowledge from the slave.
11. Enable master reception to receive serial memory data.
12. Generate an  $\overline{\text{ACK}}$  or NACK condition at the end of a received byte of data.
13. Generate a Stop condition on SDAx and SCLx.

**Figure 19-6: Typical I<sup>2</sup>C™ Message: Read of Serial EEPROM (Random Address Mode)**

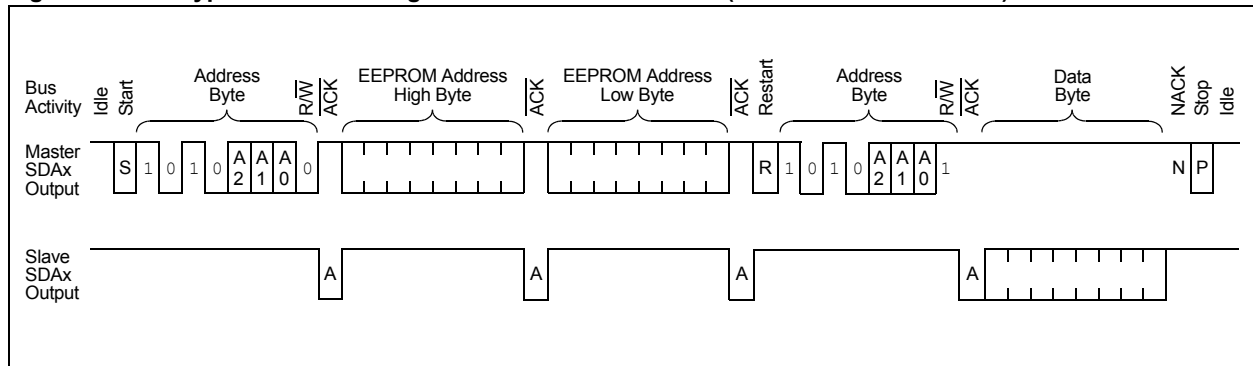

The I<sup>2</sup>C module supports Master mode communication with the inclusion of Start and Stop generators, data byte transmission, data byte reception, Acknowledge generator and a Baud Rate Generator. Generally, the software will write to a control register to start a particular step, then wait for an interrupt or poll status to wait for completion.

Subsequent sections detail each of these operations.

**Note:** The I<sup>2</sup>C module does not allow queueing of events. For instance, the software is not allowed to initiate a Start condition and immediately write the I2CxTRN register to initiate transmission before the Start condition is complete. In this case, the I2CxTRN register will not be written to and the IWCOL status bit will be set, indicating that this write to the I2CxTRN register did not occur.

## 19.5.1 Generating Start Bus Event

To initiate a Start event, the software sets the Start Enable bit, SEN (I2CxCON<0>). Prior to setting the Start bit, the software can check the P status bit (I2CxSTAT<4>) to ensure that the bus is in an Idle state.

Figure 19-7 shows the timing of the Start condition.

- Slave logic detects the Start condition, sets the S status bit (I2CxSTAT<3>) and clears the P status bit (I2CxSTAT<4>).
- SEN bit is automatically cleared at completion of the Start condition.
- MI2CxIF interrupt is generated at completion of the Start condition.
- After the Start condition, the SDAx line and SCLx line are left low (Q state).

### 19.5.1.1 IWCOL STATUS FLAG

If the software writes the I2CxTRN register when a Start sequence is in progress, the IWCOL status bit is set and the contents of the transmit buffer are unchanged (the write doesn't occur).

**Note:** Because queueing of events is not allowed, writing to the lower 5 bits of the I2CxCON register is disabled until the Start condition is complete.

**Figure 19-7: Master Start Timing Diagram**

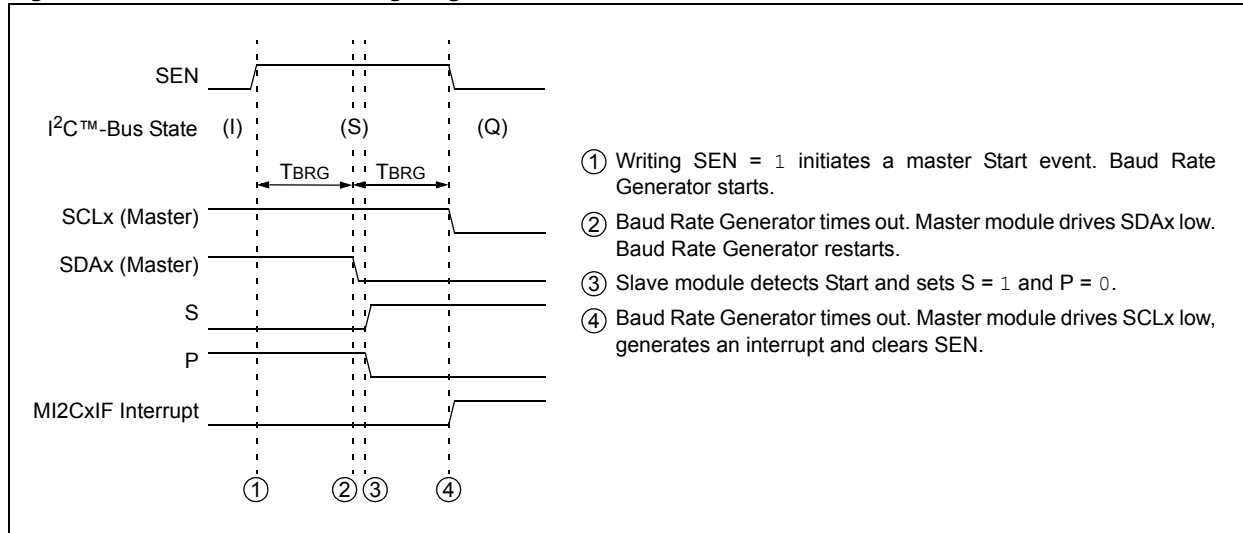

## 19.5.2 Sending Data to a Slave Device

Transmission of a data byte, a 7-bit device address byte or the second byte of a 10-bit address is accomplished by simply writing the appropriate value to the I2CxTRN register. Loading this register will start the following process:

- The software loads the I2CxTRN register with the data byte to transmit.
- Writing the I2CxTRN register sets the buffer full flag bit, TBF (I2CxSTAT<0>).
- The data byte is shifted out through the SDAx pin until all 8 bits are transmitted. Each bit of address/data will be shifted out onto the SDAx pin after the falling edge of SCLx.
- On the ninth SCLx clock, the module shifts in the  $\overline{\text{ACK}}$  bit from the slave device and writes its value into the ACKSTAT status bit (I2CxSTAT<15>).
- The module generates the MI2CxIF interrupt at the end of the ninth SCLx clock cycle.

The module does not generate or validate the data bytes. The contents and usage of the bytes are dependent on the state of the message protocol maintained by the software.



## 19.5.2.1 SENDING A 7-BIT ADDRESS TO THE SLAVE

Sending a 7-bit device address involves sending one byte to the slave. A 7-bit address byte must contain the 7 bits of the I<sup>2</sup>C device address and a R/W status bit that defines whether the message will be a write to the slave (master transmission and slave reception) or a read from the slave (slave transmission and master reception).

**Note:** In 7-bit addressing mode, each node using the I<sup>2</sup>C protocol should be configured with a unique address that is stored in the I2CxADD register.

## 19.5.2.2 SENDING A 10-BIT ADDRESS TO THE SLAVE

Sending a 10-bit device address involves sending 2 bytes to the slave. The first byte contains 5 bits of the I<sup>2</sup>C device address reserved for 10-bit Addressing modes and 2 bits of the 10-bit address. Because the next byte, which contains the remaining 8 bits of the 10-bit address, must be received by the slave, the R/W status bit in the first byte must be '0', indicating master transmission and slave reception. If the message data is also directed toward the slave, the master can continue sending the data. However, if the master expects a reply from the slave, a Repeated Start sequence with the R/W status bit at '1' will change the R/W state of the message to a read of the slave.

**Note:** In 10-bit addressing mode, each node using the I<sup>2</sup>C protocol should be configured with a unique address that is stored in the I2CxADD register.

## 19.5.2.3 RECEIVING ACKNOWLEDGE FROM THE SLAVE

On the falling edge of the eighth SCLx clock, the TBF status bit is cleared and the master will deassert the SDAx pin, allowing the slave to respond with an Acknowledge. The master will then generate a ninth SCLx clock.

This allows the slave device being addressed to respond with an  $\overline{\text{ACK}}$  bit during the ninth bit time if an address match occurs or data was received properly. A slave sends an Acknowledge when it has recognized its device address (including a general call) or when the slave has properly received its data.

The status of  $\overline{\text{ACK}}$  is written into the Acknowledge Status bit, ACKSTAT (I2CxSTAT<15>), on the falling edge of the ninth SCLx clock. After the ninth SCLx clock, the module generates the MI2CxIF interrupt and enters an Idle state until the next data byte is loaded into the I2CxTRN register.

## 19.5.2.4 ACKSTAT STATUS FLAG

The ACKSTAT status bit (I2CxSTAT<15>) is cleared when the slave has sent an Acknowledge ( $\overline{\text{ACK}} = 0$ ) and is set when the slave does not Acknowledge ( $\overline{\text{ACK}} = 1$ ).

## 19.5.2.5 TBF STATUS FLAG

When transmitting, the TBF status bit (I2CxSTAT<0>) is set when the CPU writes to the I2CxTRN register and is cleared when all 8 bits are shifted out.

## 19.5.2.6 IWCOL STATUS FLAG

If the software attempts to write to the I2CxTRN register when a transmit is already in progress (i.e., the module is still shifting out a data byte), the IWCOL status bit is set and the contents of the buffer are unchanged (the write does not occur). The IWCOL status bit must be cleared in software.

**Note:** Because queueing of events is not allowed, writing to the lower five bits of the I2CxCON register is disabled until the transmit condition is complete.

**Figure 19-8: Master Transmission Timing Diagram**

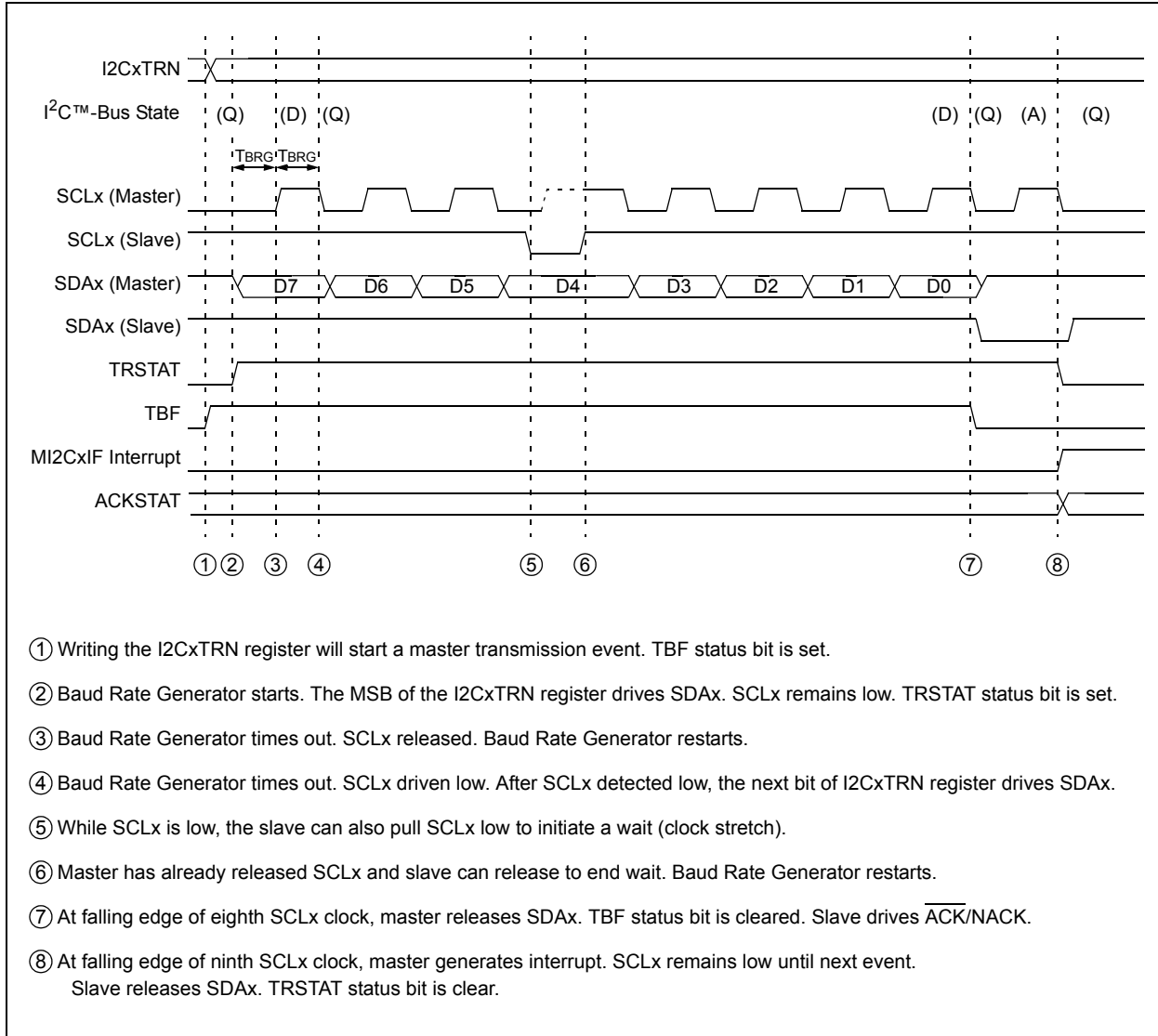

### 19.5.3 Receiving Data from a Slave Device

The master can receive data from a slave device after the master has transmitted the slave address with an R/W status bit value of '1'. This is enabled by setting the Receive Enable bit, RCEN (I2CxCON<3>). The master logic begins to generate clocks, and before each falling edge of the SCLx, the SDAx line is sampled and data is shifted into the I2CxRSR register.

**Note:** The lower 5 bits of the I2CxCON register must be '0' before attempting to set the RCEN bit. This ensures the master logic is inactive.

After the falling edge of the eighth SCLx clock, the following events occur:

- The RCEN bit is automatically cleared.
- The contents of the I2CxRSR register transfer into the I2CxRCV register.
- The RBF status bit is set.
- The module generates the MI2CxIF interrupt.

When the CPU reads the buffer, the RBF status bit is automatically cleared. The software can process the data and then execute an Acknowledge sequence.

## 19.5.3.1 RBF STATUS FLAG

When receiving data, the RBF status bit is set when a device address or data byte is loaded into the I2CxRCV register from the I2CxRSR register. It is cleared when software reads the I2CxRCV register.

## 19.5.3.2 I2COV STATUS FLAG

If another byte is received in the I2CxRSR register while the RBF status bit remains set and the previous byte remains in the I2CxRCV register, the I2COV status bit is set and the data in the I2CxRSR register is lost.

Leaving the I2COV status bit set does not inhibit further reception. If the RBF status bit is cleared by reading the I2CxRCV register and the I2CxRSR register receives another byte, that byte will be transferred to the I2CxRCV register.

## 19.5.3.3 IWCOL STATUS FLAG

If the software writes the I2CxTRN register when a receive is already in progress (i.e., the I2CxRSR register is still shifting in a data byte), the IWCOL status bit is set and the contents of the buffer are unchanged (the write doesn't occur).

**Note:** Since queuing of events is not allowed, writing to the lower five bits of the I2CxCON register is disabled until the data reception condition is complete.

**Figure 19-9: Master Reception Timing Diagram**

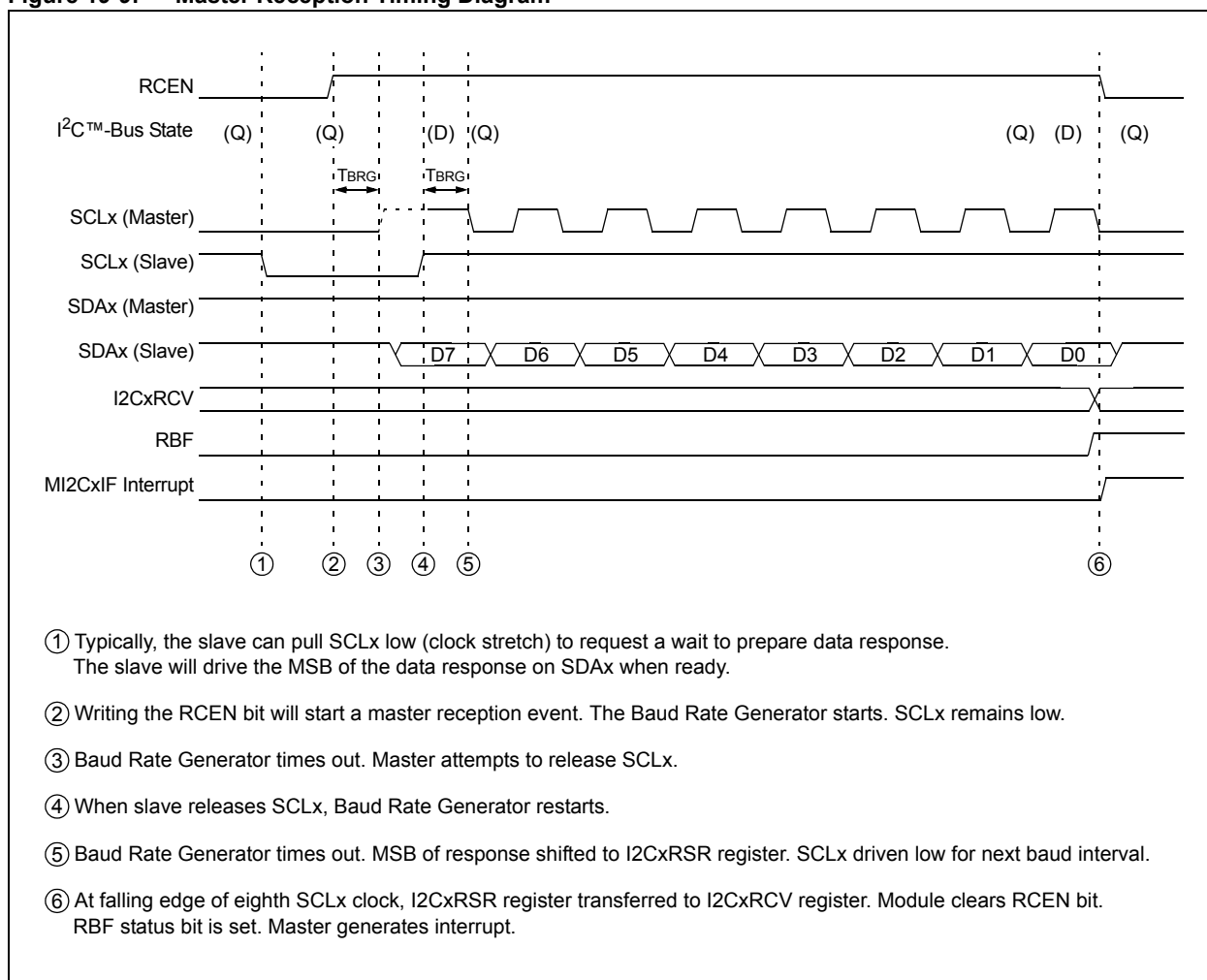

## 19.5.4 Acknowledge Generation

Setting the Acknowledge Enable bit, ACKEN (I2CxCON<4>), enables generation of a master Acknowledge sequence.

**Note:** The lower five bits of the I2CxCON register must be '0' (master logic inactive) before attempting to set the ACKEN bit.

Figure 19-10 shows an  $\overline{\text{ACK}}$  sequence and Figure 19-11 shows a NACK sequence. The Acknowledge Data bit, ACKDT (I2CxCON<5>), specifies ACK or NACK.

After two baud periods, the ACKEN bit is automatically cleared and the module generates the MI2CxIF interrupt.

### 19.5.4.1 IWCOL STATUS FLAG

If the software writes the I2CxTRN register when an Acknowledge sequence is in progress, the IWCOL status bit is set and the contents of the buffer are unchanged (the write doesn't occur).

**Note:** Because queuing of events is not allowed, writing to the lower five bits of the I2CxCON register is disabled until the Acknowledge condition is complete.

**Figure 19-10: Master Acknowledge ( $\overline{\text{ACK}}$ ) Timing Diagram**

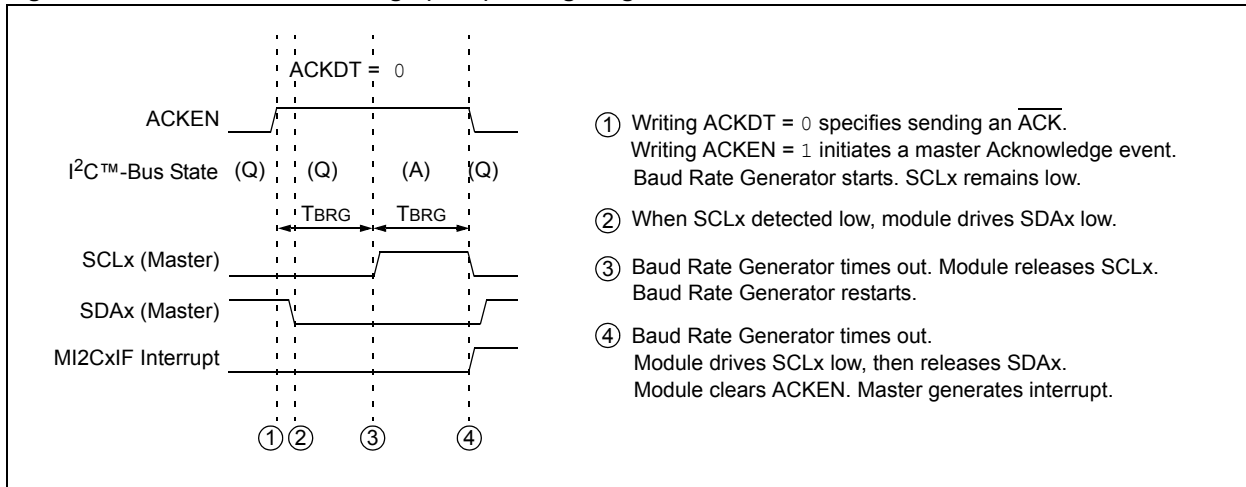

**Figure 19-11: Master Not Acknowledge (NACK) Timing Diagram**

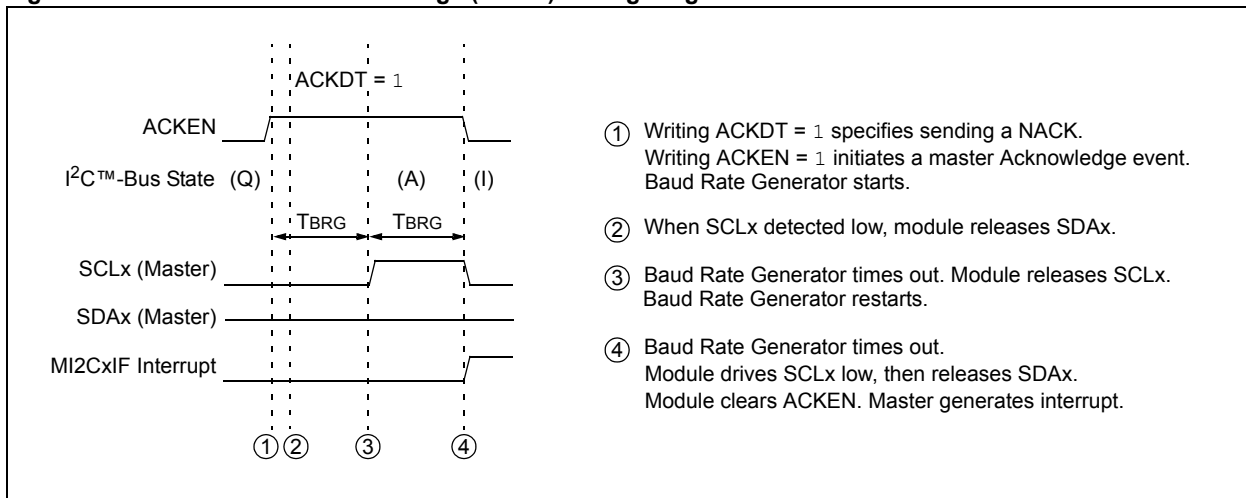

## 19.5.5 Generating Stop Bus Event

Setting the Stop Enable bit, PEN (I2CxCON<2>), enables generation of a master Stop sequence.

**Note:** The lower 5 bits of the I2CxCON register must be '0' (master logic inactive) before attempting to set the PEN bit.

When the PEN bit is set, the master generates the Stop sequence as shown in Figure 19-12.

- The slave detects the Stop condition, sets the P status bit (I2CxSTAT<4>) and clears the S status bit (I2CxSTAT<3>).
- The PEN bit is automatically cleared.
- The module generates the MI2CxIF interrupt.

### 19.5.5.1 IWCOL STATUS FLAG

If the software writes the I2CxTRN register when a Stop sequence is in progress, the IWCOL status bit is set and the contents of the buffer are unchanged (the write doesn't occur).

**Note:** Because queuing of events is not allowed, writing to the lower five bits of the I2CxCON register is disabled until the Stop condition is complete.

**Figure 19-12: Master Stop Timing Diagram**

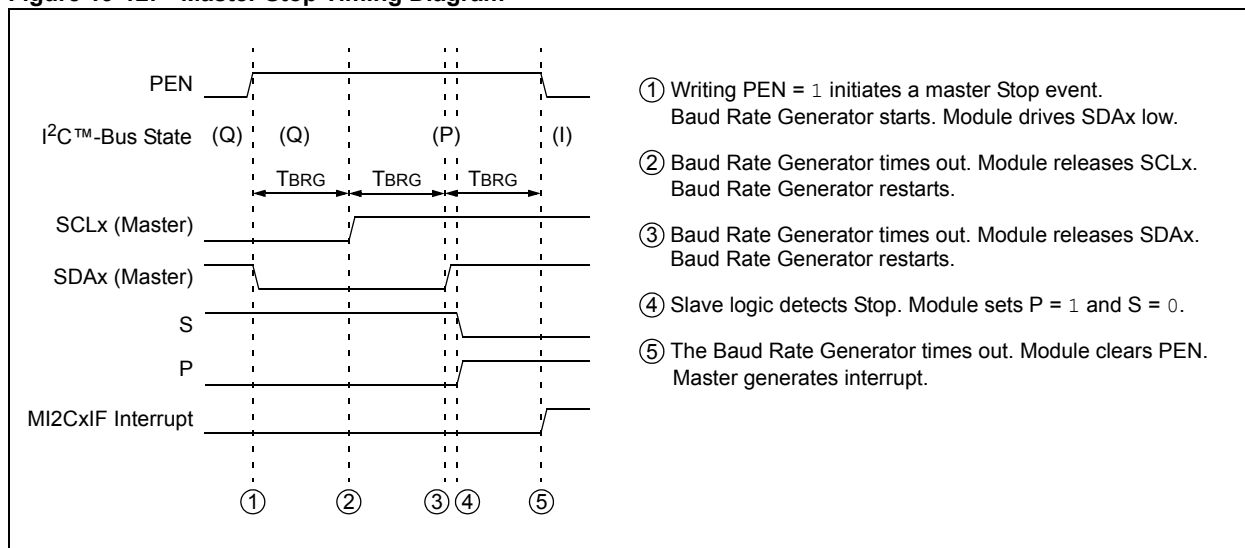

## 19.5.6 Generating Repeated Start Bus Event

Setting the Repeated Start Enable bit, RSEN (I2CxCON<1>), enables generation of a master Repeated Start sequence (see Figure 19-13).

**Note:** The lower five bits of the I2CxCON register must be '0' (master logic inactive) before attempting to set the RSEN bit.

To generate a Repeated Start condition, software sets the RSEN bit (I2CxCON<1>). The module asserts the SCLx pin low. When the module samples the SCLx pin low, the module releases the SDAx pin for one Baud Rate Generator count (TBRG). When the Baud Rate Generator times out and the module samples SDAx high, the module deasserts the SCLx pin. When the module samples the SCLx pin high, the Baud Rate Generator reloads and begins counting. SDAx and SCLx must be sampled high for one TBRG. This action is then followed by assertion of the SDAx pin low for one TBRG while SCLx is high.

The following is the Repeated Start sequence:

- The slave detects the Start condition, sets the S status bit (I2CxSTAT<3>) and clears the P status bit (I2CxSTAT<4>).
- The RSEN bit is automatically cleared.
- The module generates the MI2CxIF interrupt.

### 19.5.6.1 IWCOL STATUS FLAG

If the software writes the I2CxTRN register when a Repeated Start sequence is in progress, the IWCOL status bit is set and the contents of the buffer are unchanged (the write does not occur).

**Note:** Because queuing of events is not allowed, writing of the lower five bits of the I2CxCON register is disabled until the Repeated Start condition is complete.

**Figure 19-13: Master Repeated Start Timing Diagram**

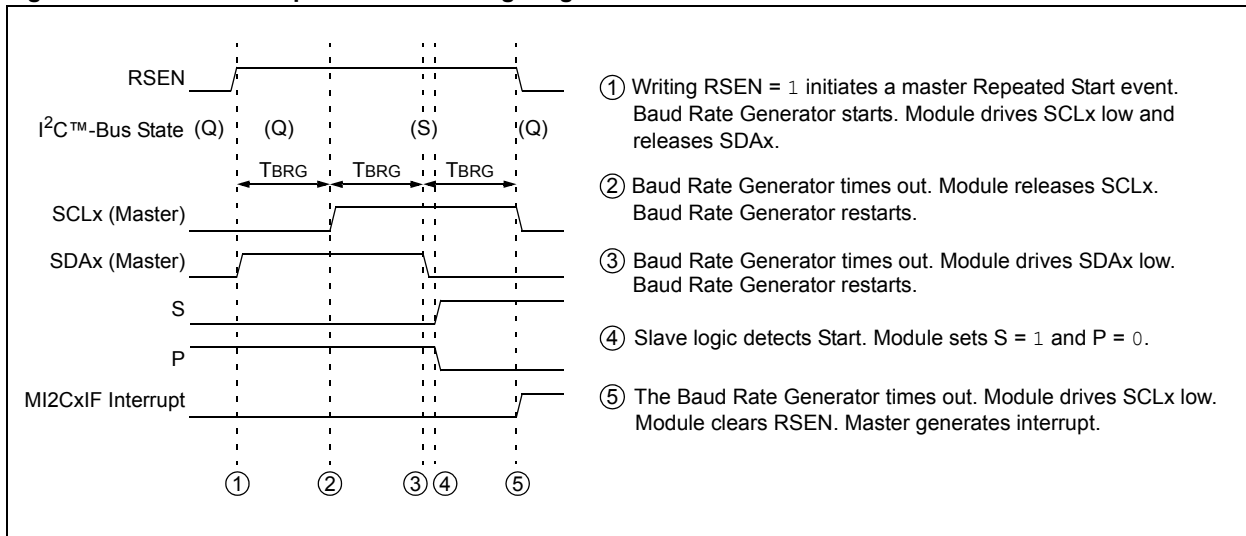

## 19.5.7 Building Complete Master Messages

As described at the beginning of 19.5 “Communicating as a Master in a Single-Master Environment”, the software is responsible for constructing messages with the correct message protocol. The module controls individual portions of the I<sup>2</sup>C message protocol; however, sequencing of the components of the protocol to construct a complete message is a software task.

The software can use polling or interrupt methods while using the module. The examples shown use interrupts.

The software can use the SEN, RSEN, PEN, RCEN, and ACKEN bits (Least Significant 5 bits of the I2CxCON register) and the TRSTAT status bit as a “state” flag when progressing through a message. For example, Table 19-2 shows some example state numbers associated with bus states.

**Table 19-2: Master Message Protocol States**

Example State Number	I2CxCON<4:0>	TRSTAT (I2CxSTAT<14>)	State
0	00000	0	Bus Idle or Wait
1	00001	N/A	Sending Start Event
2	00000	1	Master Transmitting
3	00010	N/A	Sending Repeated Start Event
4	00100	N/A	Sending Stop Event
5	01000	N/A	Master Reception
6	10000	N/A	Master Acknowledgement

**Note:** Example state numbers for reference only. User software can assign state numbers as desired.

The software will begin a message by issuing a Start command. The software will record the state number corresponding to the Start.

As each event completes and generates an interrupt, the interrupt handler may check the state number. So, for a Start state, the interrupt handler will confirm execution of the Start sequence and then start a master transmission event to send the I<sup>2</sup>C device address, changing the state number to correspond to the master transmission.

On the next interrupt, the interrupt handler will again check the state, determining that a master transmission just completed. The interrupt handler will confirm successful transmission of the data, then move on to the next event, depending on the contents of the message. In this manner, on each interrupt, the interrupt handler will progress through the message protocol until the complete message is sent.

Figure 19-14 provides a more detailed examination of the same message sequence shown in Figure 19-6. Figure 19-15 shows some simple examples of messages using 7-bit addressing format. Figure 19-16 shows an example of a 10-bit addressing format message sending data to a slave. Figure 19-17 shows an example of a 10-bit addressing format message receiving data from a slave.

Figure 19-14: Master Message (Typical I<sup>2</sup>C™ Message: Read of Serial EEPROM)

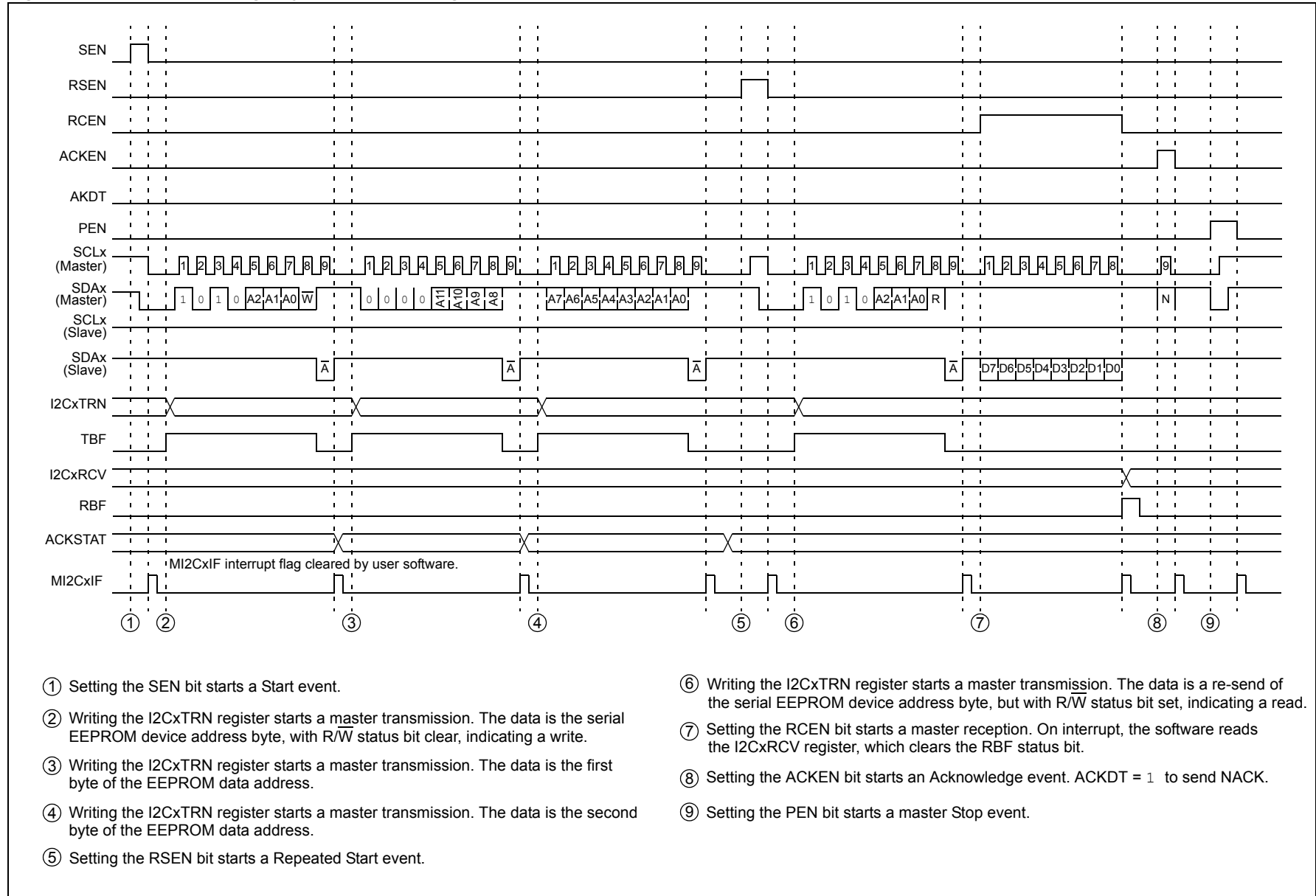



**Figure 19-15: Master Message (7-Bit Address: Transmission And Reception)**

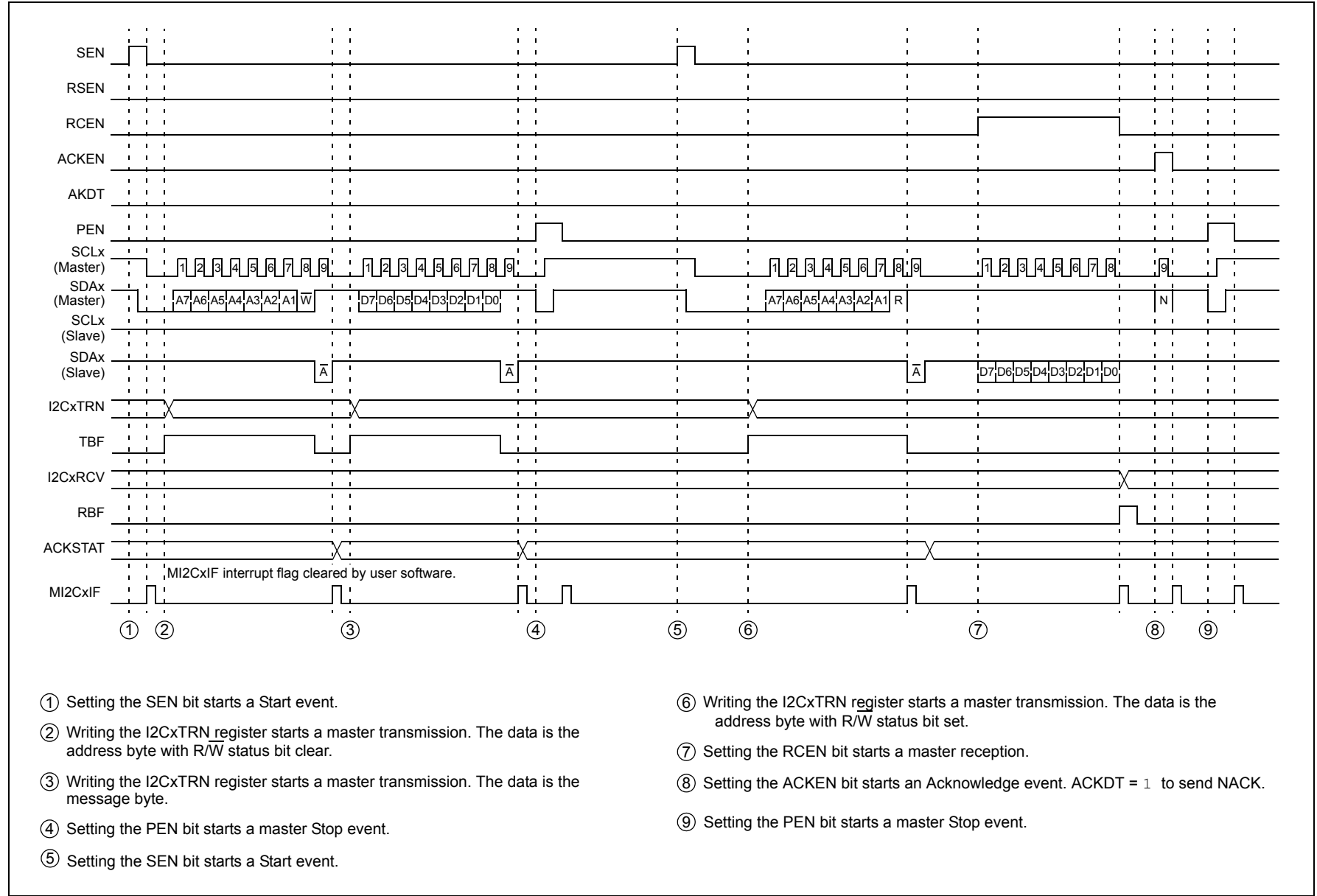

Figure 19-16: Master Message (10-Bit Transmission)

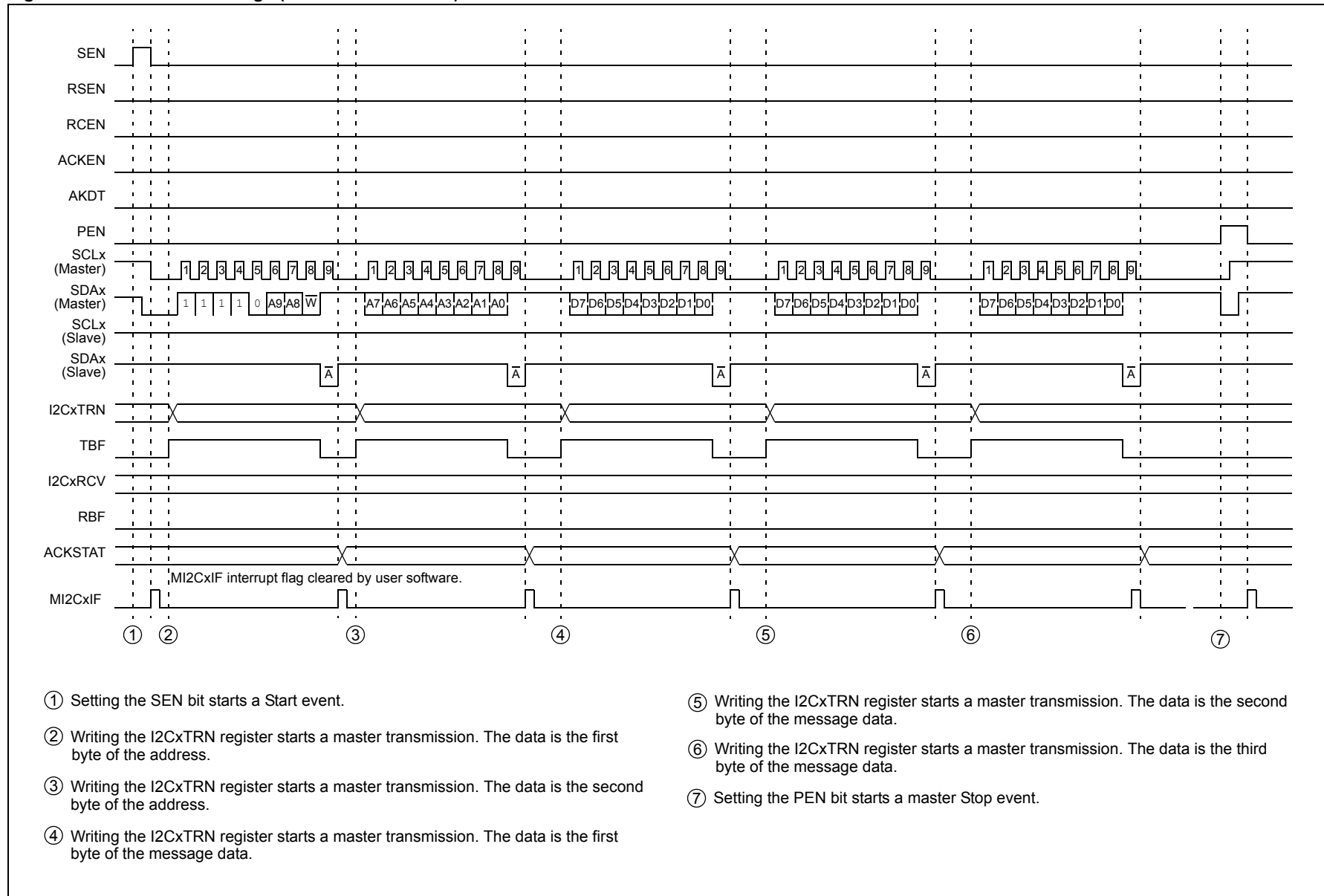
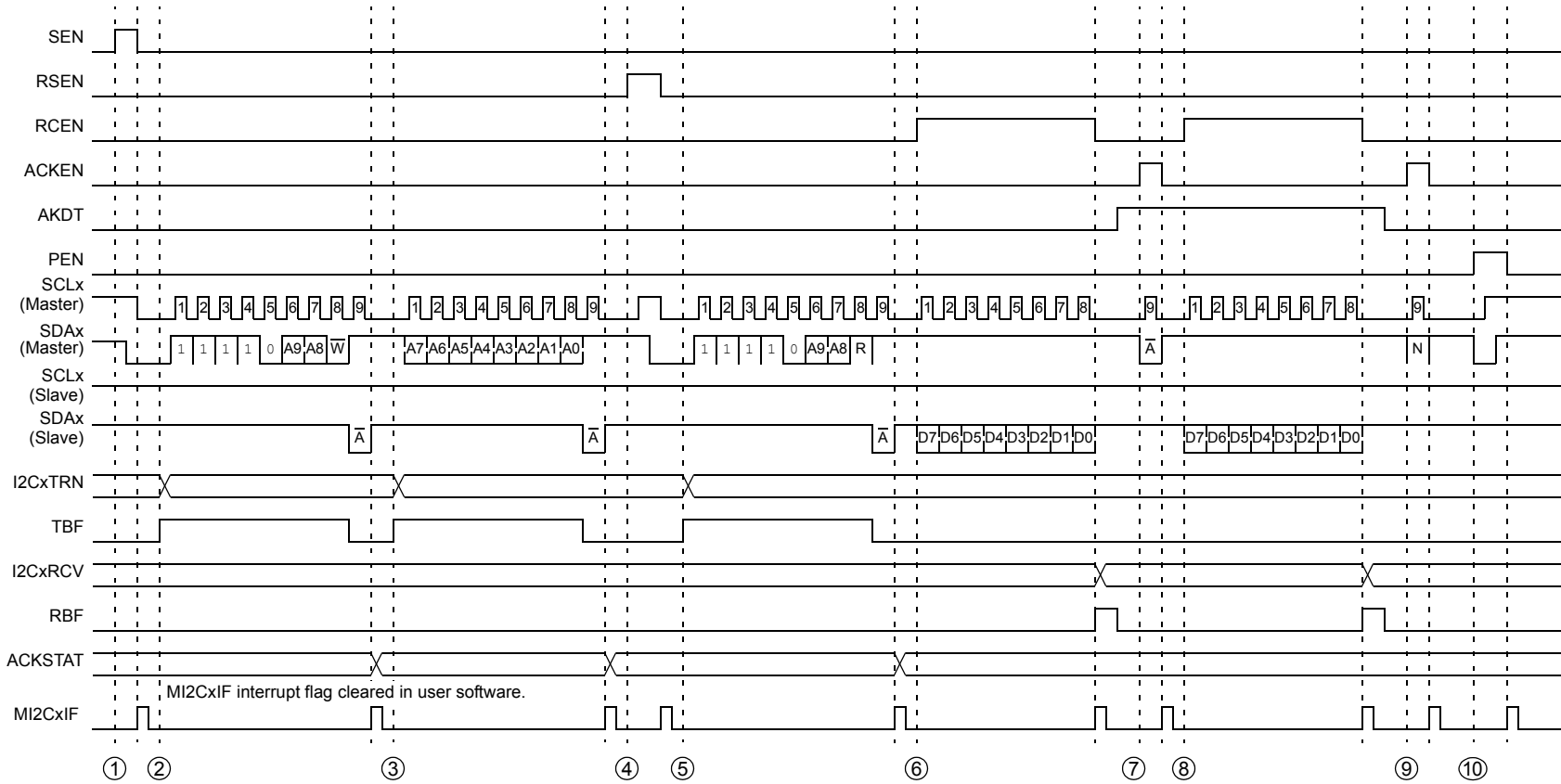

Figure 19-17: Master Message (10-Bit Reception)



- ① Setting the SEN bit starts a Start event.
- ② Writing the I2CxTRN register starts a master transmission. The data is the first byte of the address with the R/W status bit cleared.
- ③ Writing the I2CxTRN register starts a master transmission. The data is the second byte of the address.
- ④ Setting the RSEN bit starts a master Restart event.
- ⑤ Writing the I2CxTRN register starts a master transmission. The data is a re-send of the first byte with the R/W status bit set.
- ⑥ Setting the RCEN bit starts a master reception. On interrupt, the software reads the I2CxRCV register, which clears the RBF status bit.
- ⑦ Setting the ACKEN bit starts an Acknowledge event. ACKDT = 0 to send  $\overline{\text{ACK}}$ .
- ⑧ Setting the RCEN bit starts a master reception.
- ⑨ Setting the ACKEN bit starts an Acknowledge event. ACKDT = 1 to send NACK.
- ⑩ Setting the PEN bit starts a master Stop event.

## 19.6 COMMUNICATING AS A MASTER IN A MULTI-MASTER ENVIRONMENT

The I<sup>2</sup>C protocol allows for more than one master to be attached to a system bus. Taking into account that a master can initiate message transactions and generate clocks for the bus, the protocol has methods to account for situations where more than one master is attempting to control the bus. Clock synchronization ensures that multiple nodes can synchronize their SCLx clocks to result in one common clock on the SCLx line. Bus arbitration ensures that if more than one node attempts a message transaction, only one node, will be successful in completing the message. The other nodes lose bus arbitration and are left with a bus collision.

### 19.6.1 Multi-Master Operation

The master module has no special settings to enable multi-master operation. The module performs clock synchronization and bus arbitration at all times. If the module is used in a single-master environment, clock synchronization only occurs between the master and slaves, and bus arbitration does not occur.

### 19.6.2 Master Clock Synchronization

In a multi-master system, different masters can have different baud rates. Clock synchronization ensures that when these masters are attempting to arbitrate the bus, their clocks will be coordinated.

Clock synchronization occurs when the master deasserts the SCLx pin (SCLx intended to float high). When the SCLx pin is released, the Baud Rate Generator (BRG) is suspended from counting until the SCLx pin is actually sampled high. When the SCLx pin is sampled high, the Baud Rate Generator is reloaded with the contents of I2CxBRG<8:0> and begins counting. This ensures that the SCLx high time will always be at least one BRG rollover count in the event that the clock is held low by an external device, as shown in Figure 19-18.

**Figure 19-18: Baud Rate Generator Timing with Clock Synchronization**

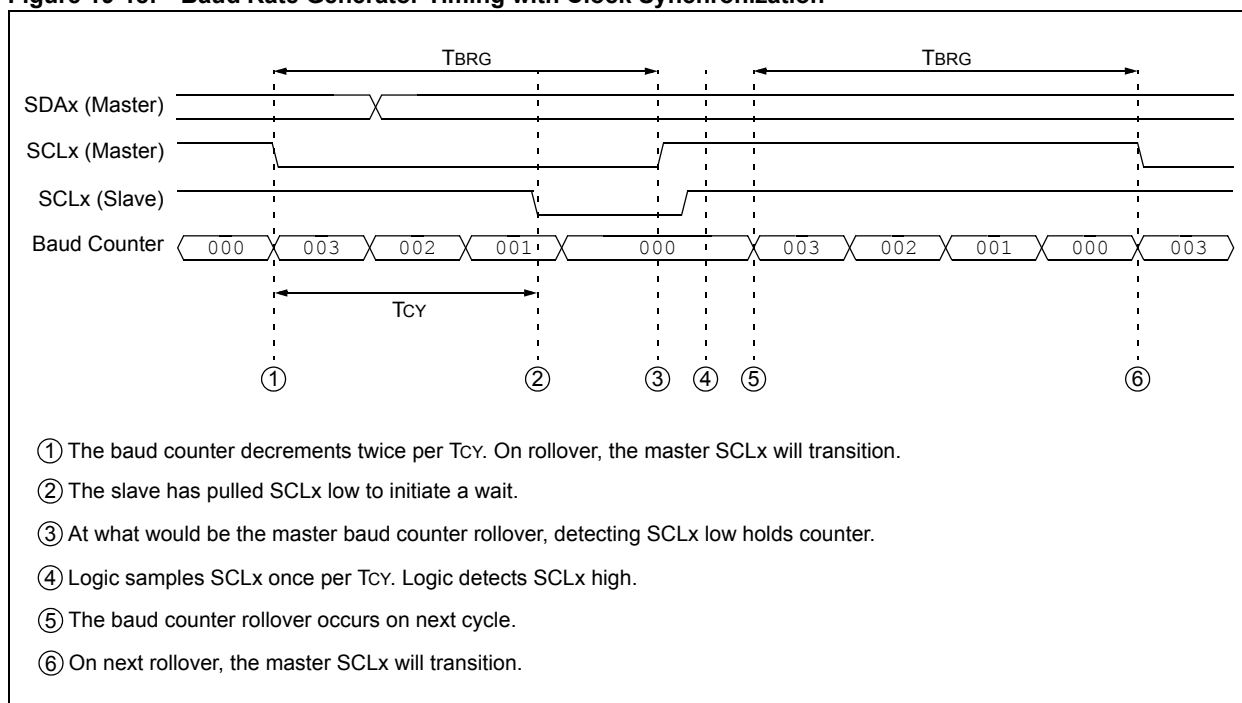

## 19.6.3 Bus Arbitration and Bus Collision

Bus arbitration supports multi-master system operation. The wired AND nature of the SDAx line permits arbitration. Arbitration takes place when the first master outputs a '1' on SDAx by letting SDAx float high and simultaneously, the second master outputs a '0' on SDAx by pulling SDAx low. The SDAx signal will go low. In this case, the second master has won bus arbitration. The first master has lost bus arbitration and thus, has a bus collision.

For the first master, the expected data on SDAx is a '1', yet the data sampled on SDAx is a '0'. This is the definition of a bus collision.

The first master will set the Master Bus Collision bit, BCL (I2CxSTAT<10>), and generate a master interrupt. The master module will reset the I<sup>2</sup>C port to its Idle state.

In multi-master operation, the SDAx line must be monitored for arbitration to see if the signal level is the expected output level. This check is performed by the master module, with the result placed in the BCL status bit.

The states where arbitration can be lost are:

- A Start condition
- A Repeated Start condition
- The Address, Data, or Acknowledge bit
- A Stop condition

## 19.6.4 Detecting Bus Collisions and Re-sending Messages

When a bus collision occurs, the module sets the BCL status bit and generates a master interrupt. If a bus collision occurs during a byte transmission, the transmission is halted, the TBF status bit is cleared and the SDAx and SCLx pins are deasserted. If a bus collision occurs during a Start, Repeated Start, Stop, or Acknowledge condition, the condition is aborted, the respective control bits in the I2CxCON register are cleared and the SDAx and SCLx lines are deasserted.

The software is expecting an interrupt at the completion of the master event. The software can check the BCL status bit to determine if the master event completed successfully or a bus collision occurred. If a bus collision occurs, the software must abort sending the rest of the pending message and prepare to re-send the entire message sequence, beginning with the Start condition, after the bus returns to an Idle state. The software can monitor the S and P status bits to wait for an Idle bus. When the software services the master Interrupt Service Routine and the I<sup>2</sup>C-bus is free, the software can resume communication by asserting a Start condition.

## 19.6.5 Bus Collision During a Start Condition

Before issuing a Start command, the software should verify an Idle state of the bus using the S and P status bits. Two masters may attempt to initiate a message at a similar point in time. Typically, the masters will synchronize clocks and continue arbitration into the message until one loses arbitration. However, the following conditions can cause a bus collision to occur during a Start:

- If the SDA and SCL pins are at a low logic state at the beginning of the Start condition, or
- If the SCL line is at a low logic state before the SDA line is driven low

In either case, the master that loses arbitration during the Start bit generates a bus collision interrupt.

## 19.6.6 Bus Collision During a Repeated Start Condition

Should two masters not collide throughout an address byte, a bus collision can occur when one master attempts to assert a Repeated Start while another transmits data. In this case, the master generating the Repeated Start loses arbitration and generates a bus collision interrupt.

## 19.6.7 Bus Collision During Message Bit Transmission

The most typical case of data collision occurs while the master is attempting to transmit the device address byte, a data byte or an Acknowledge bit.

If the software is properly checking the bus state, it is unlikely that a bus collision will occur on a Start condition. However, because another master can, at a very similar time, check the bus and initiate its own Start condition, it is likely that SDAx arbitration will occur and synchronize the Start of two masters. In this condition, both masters begin and continue to transmit their messages until one master loses arbitration on a message bit. Remember that the SCLx clock synchronization keeps the two masters synchronized until one loses arbitration. Figure 19-19 shows an example of message bit arbitration.

**Figure 19-19: Bus Collision During Message Bit Transmission**

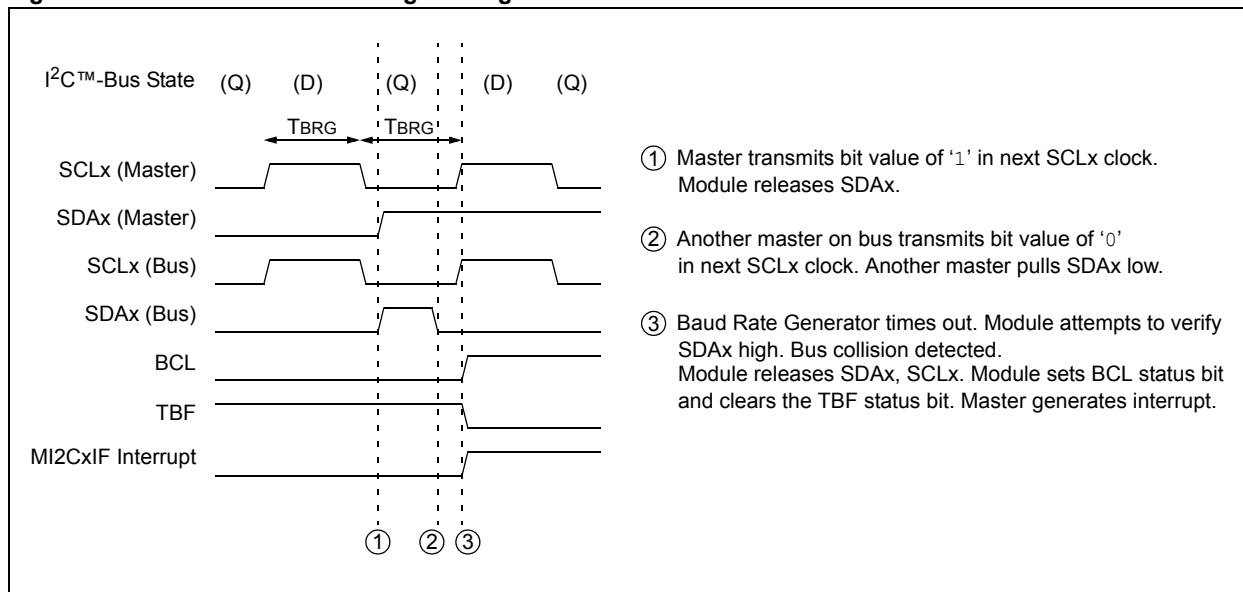

## 19.6.8 Bus Collision During a Stop Condition

If the master software loses track of the state of the I<sup>2</sup>C-bus, there are conditions too numerous to mention that can cause a bus collision during a Stop condition. In this case, the master generating the Stop condition will lose arbitration and generate a bus collision interrupt.

## 19.7 COMMUNICATING AS A SLAVE

In some systems, particularly where multiple processors communicate with each other, the PIC24H device can communicate as a slave (see Figure 19-20). When the module is enabled, the slave module is active. The slave cannot initiate a message, it can only respond to a message sequence initiated by a master. The master requests a response from a particular slave as defined by the device address byte in the I<sup>2</sup>C protocol. The slave module replies to the master at the appropriate times as defined by the protocol.

As with the master module, sequencing the components of the protocol for the reply is a software task. However, the slave module detects when the device address matches the address specified by the software for that slave.

**Figure 19-20: A Typical Slave I<sup>2</sup>C™ Message: Multiprocessor Command/Status**

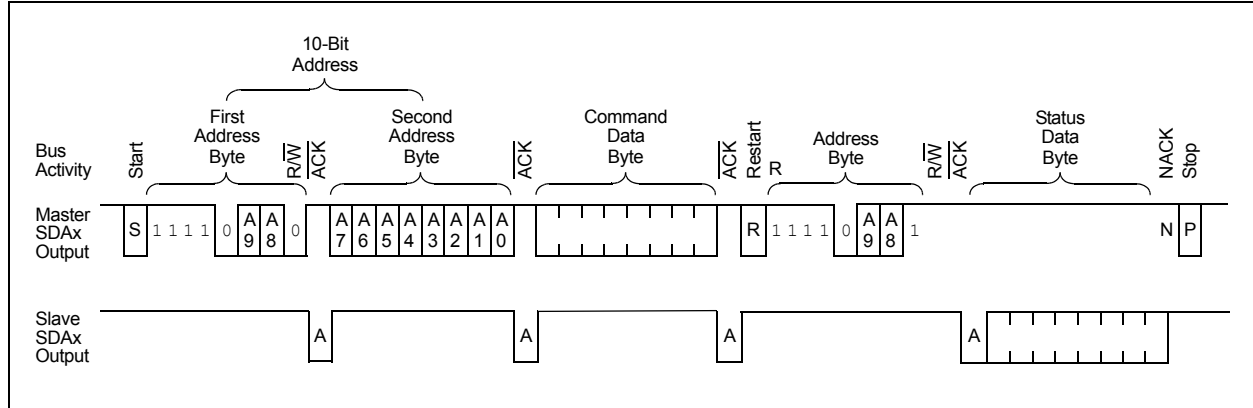

After a Start condition, the slave module receives and checks the device address. The slave can specify either a 7-bit address or a 10-bit address. When a device address is matched, the module will generate an interrupt to notify the software that its device is selected. Based on the R/W status bit sent by the master, the slave either receives or transmits data. If the slave is to receive data, the slave module automatically generates the Acknowledge (ACK), loads the I2CxRCV register with the received value currently in the I2CxRSR register, and notifies the software through an interrupt. If the slave is to transmit data, the software must load the I2CxTRN register.

### 19.7.1 Sampling Receive Data

All incoming bits are sampled with the rising edge of the clock (SCLx) line.

### 19.7.2 Detecting Start and Stop Conditions

The slave module detects Start and Stop conditions on the bus and indicates that status on the S status bit (I2CxSTAT<3>) and P status bit (I2CxSTAT<4>). The Start (S) and Stop (P) status bits are cleared when a Reset occurs or when the module is disabled. After detection of a Start or Repeated Start event, the S status bit is set and the P status bit is cleared. After detection of a Stop event, the P status bit is set and the S status bit is clear.

### 19.7.3 Detecting the Address

Once the module has been enabled, the slave module waits for a Start condition to occur. After a Start, depending on the A10M bit (I2CxCON<10>), the slave attempts to detect a 7-bit or 10-bit address. The slave module compares one received byte for a 7-bit address or two received bytes for a 10-bit address. A 7-bit address also contains an R/W status bit that specifies the direction of data transfer after the address. If R/W = 0, a write is specified and the slave receives data from the master. If R/W = 1, a read is specified and the slave sends data to the master. The 10-bit address contains an R/W status bit; however, by definition, it is always R/W = 0 because the slave must receive the second byte of the 10-bit address.

## 19.7.3.1 SLAVE ADDRESS MASKING

The I2CxMSK register masks address bit positions, designating them as “don’t care” bits for both 10-Bit and 7-Bit Addressing modes. When a bit in the I2CxMSK register is set (= 1), the slave module responds when the bit in the corresponding location of the address is a ‘0’ or ‘1’. For example, in 7-Bit Slave mode with I2CxMSK = 0100000, the module acknowledges addresses ‘0000000’ and ‘0100000’ as valid.

To enable address masking, the Intelligent Platform Management Interface (IPMI) must be disabled by clearing the IPMIEN bit (I2CxCON<11>).

## 19.7.3.2 7-BIT ADDRESS AND SLAVE WRITE

Following the Start condition, the module shifts 8 bits into the I2CxRSR register (see Figure 19-21). The value of register I2CxRSR<7:1> is evaluated against that of the I2CxADD<6:0> and I2CxMSK<6:0> registers on the falling edge of the eighth clock (SCLx). If the address is valid (i.e., an exact match between unmasked bit positions), the following events occur:

1. An  $\overline{\text{ACK}}$  is generated.
2. The D/A and R/W status bits are cleared.
3. The module generates the SI2CxIF interrupt on the falling edge of the ninth SCLx clock.
4. The module waits for the master to send data.

**Figure 19-21: Slave Write 7-Bit Address Detection Timing Diagram**

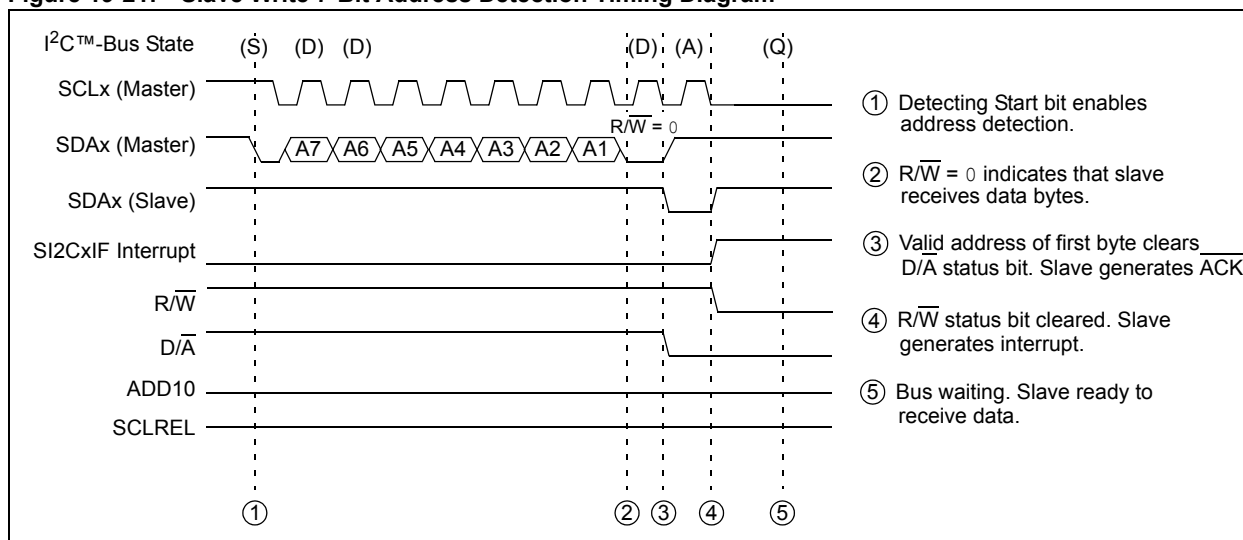

## 19.7.3.3 7-BIT ADDRESS AND SLAVE READ

When a slave read is specified by having  $\overline{\text{R/W}} = 1$  in a 7-bit address byte, the process of detecting the device address is similar to that for a slave write (see Figure 19-22). If the addresses match, the following events occur:

1. An  $\overline{\text{ACK}}$  is generated.
2. The D/A status bit is cleared and the  $\overline{\text{R/W}}$  status bit is set.
3. The module generates the SI2CxIF interrupt on the falling edge of the ninth SCLx clock.

Since the slave module is expected to reply with data at this point, it is necessary to suspend the operation of the I<sup>2</sup>C-bus to allow the software to prepare a response. This is done automatically when the module clears the SCLREL bit. With SCLREL low, the slave module will pull down the SCLx clock line, causing a wait on the I<sup>2</sup>C-bus. The slave module and the I<sup>2</sup>C-bus remain in this state until the software writes the I2CxTRN register with the response data and sets the SCLREL bit.

**Note:** SCLREL will automatically clear after detection of a slave read address, regardless of the state of the STREN bit.



**Figure 19-22: Slave Read 7-Bit Address Detection Timing Diagram**

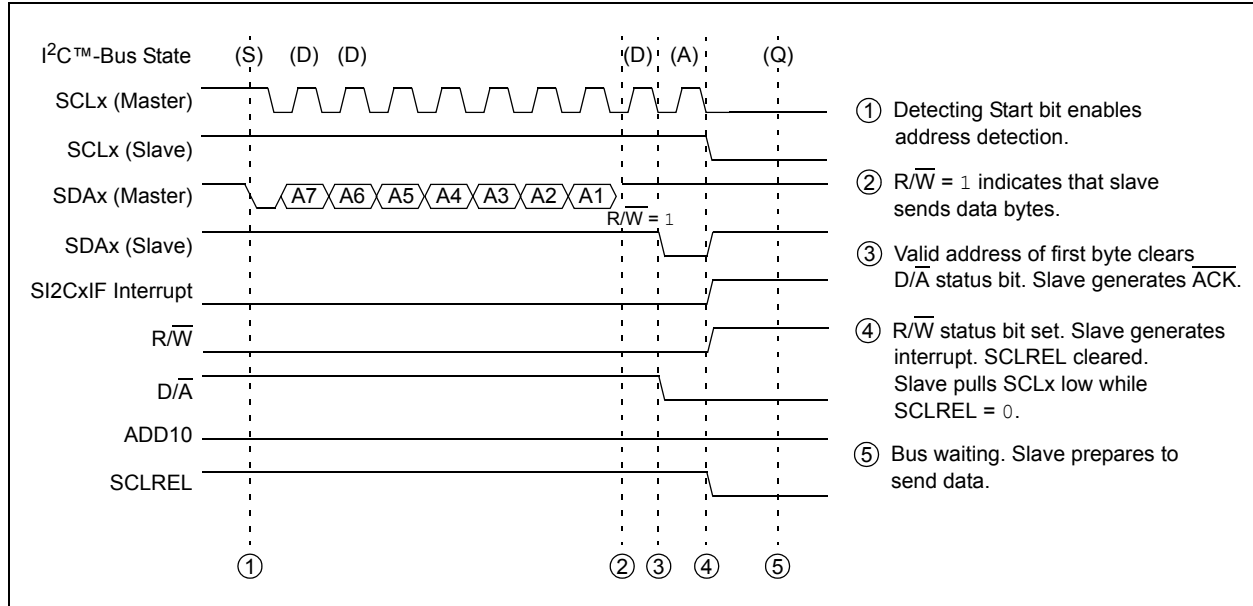

### 19.7.3.4 10-BIT ADDRESSING MODE

In 10-Bit Addressing mode, the slave must receive two device address bytes (see Figure 19-23). The five Most Significant bits (MSBs) of the first address byte specify a 10-bit address. The R/W status bit of the address must specify a write, causing the slave device to receive the second address byte. For a 10-bit address, the first byte would equal '11110 A9 A8 0', where 'A9' and 'A8' are the two MSBs of the address.

The I2CxMSK register can mask any bit position in a 10-bit address. The two MSBs of the I2CxMSK register are used to mask the MSBs of the incoming address received in the first byte. The remaining byte of the register is then used to mask the lower byte of the address received in the second byte.

Following the Start condition, the module shifts eight bits into the I2CxRSR register. The value of the I2CxRSR<2:1> bits are evaluated against the value of the I2CxADD<9:8> and I2CxMSK<9:8> bits, while the value of the I2CxRSR<7:3> bits are compared to '11110'. Address evaluation occurs on the falling edge of the eighth clock (SCLx). For the address to be valid, I2CxRSR<7:3> must equal '11110', while I2CxRSR<2:1> must exactly match any unmasked bits in I2CxADD<9:8>. (If both bits are masked, a match is not needed.) If the address is valid, the following events occur:

1. An  $\overline{ACK}$  is generated.
2. The  $\overline{D/A}$  and  $\overline{R/W}$  status bits are cleared.
3. The module generates the SI2CxIF interrupt on the falling edge of the ninth SCLx clock.

The module does generate an interrupt after the reception of the first byte of a 10-bit address; however, this interrupt is of little use.

The module will continue to receive the second byte into the I2CxRSR register. This time, the I2CxRSR<7:0> bits are evaluated against the I2CxADD<7:0> and I2CxMSK<7:0> bits. If the lower byte of the address is valid as previously described, the following events occur:

1. An  $\overline{ACK}$  is generated.
2. The ADD10 status bit is set.
3. The module generates the SI2CxIF interrupt on the falling edge of the ninth SCLx clock.
4. The module will wait for the master to send data or initiate a Repeated Start condition.

**Note:** Following a Repeated Start condition in 10-Bit Addressing mode, the slave module only matches the first 7-bit address, '11110 A9 A8 0'.

**Figure 19-23: 10-Bit Address Detection Timing Diagram**

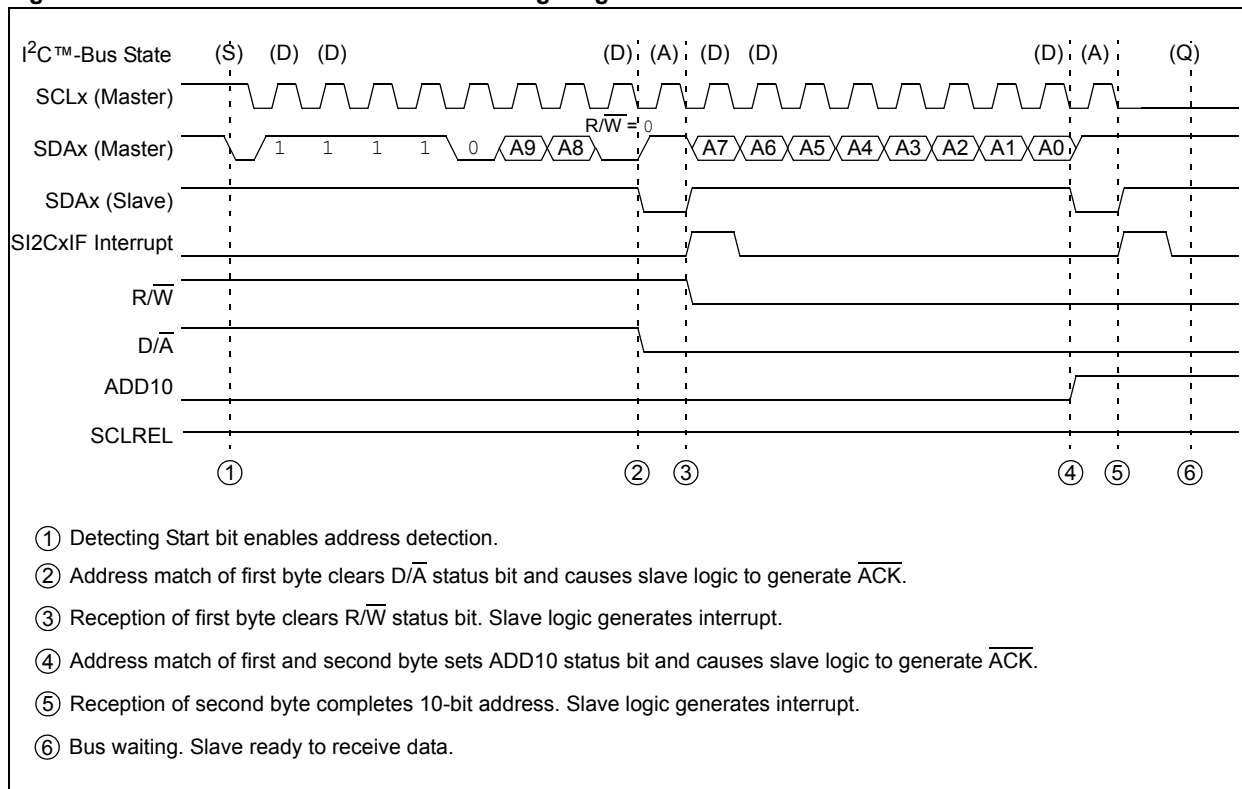

### 19.7.3.5 GENERAL CALL OPERATION

The addressing procedure for the I<sup>2</sup>C-bus is such that the first byte after a Start condition usually determines which slave device the master is addressing. The exception is the general call address, which can address all devices. When this address is used, all enabled devices respond with an Acknowledge. The general call address is one of eight addresses reserved for specific purposes by the I<sup>2</sup>C protocol. It consists of all '0's with  $\overline{R/W} = 0$ . The general call is always a slave write operation.

The general call address is recognized when the General Call Enable bit, GCEN (I2CxCON<7>), is set (see Figure 19-24). Following a Start bit detect, eight bits are shifted into the I2CxRSR register and the address is compared against the I2CxADD register and the general call address.

If the general call address matches, the following events occur:

1. An  $\overline{ACK}$  is generated.
2. Slave module will set the GCSTAT status bit (I2CxSTAT<9>).
3. The  $\overline{D/A}$  and  $\overline{R/W}$  status bits are cleared.
4. The module generates the SI2CxIF interrupt on the falling edge of the ninth SCLx clock.
5. The I2CxRSR register is transferred to the I2CxRCV register and the RBF status bit is set (during the eighth bit).
6. The module waits for the master to send data.

When the interrupt is serviced, the cause for the interrupt can be checked by reading the contents of the GCSTAT status bit to determine if the device address was device specific or a general call address.

Note that general call addresses are 7-bit addresses. If configuring the slave module for 10-bit addresses and the A10M and GCEN bits are set, the slave module will continue to detect the 7-bit general call address.

**Figure 19-24: General Call Address Detection Timing Diagram (GCEN = 1)**

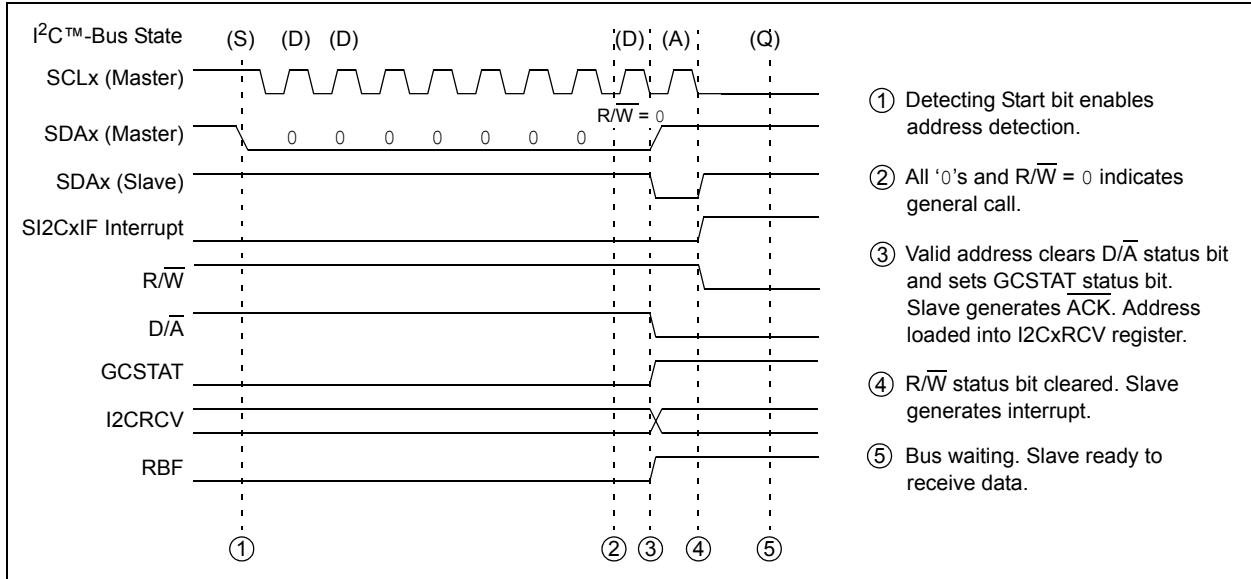

### 19.7.3.6 RECEIVING ALL ADDRESSES (IPMI OPERATION)

Some I<sup>2</sup>C system protocols require a slave to act upon all messages on the bus. For example, the IPMI (Intelligent Platform Management Interface) bus uses I<sup>2</sup>C nodes as message repeaters in a distributed network. To allow a node to repeat all messages, the slave module must accept all messages, regardless of the device address.

To enable IPMI mode, set the IPMIEN bit (I2CxCON<11>); see Figure 19-25. Regardless of the state of the A10M and GCEN bits or the value loaded in the I2CxADD register, all addresses are accepted.

**Figure 19-25: IPMI Address Detection Timing Diagram (IPMIEN = 1)**

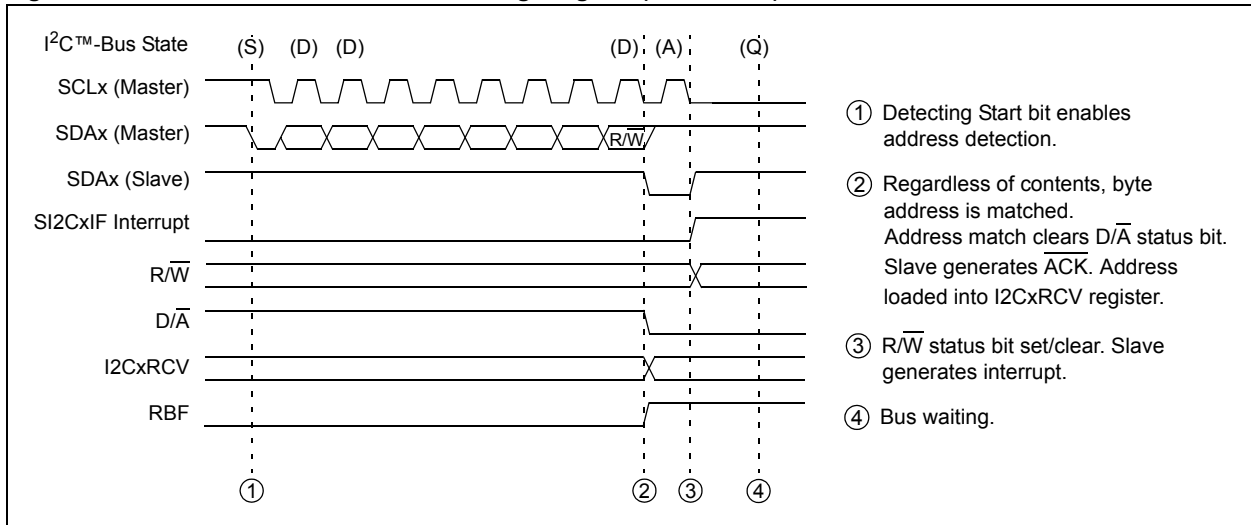

## 19.7.3.7 WHEN AN ADDRESS IS INVALID

If a 7-bit address does not match the contents of I2CxADD<6:0>, the slave module will return to an Idle state and ignore all bus activity until after the Stop condition.

If the first byte of a 10-bit address does not match the contents of I2CxADD<9:8>, the slave module will return to an Idle state and ignore all bus activity until after the Stop condition.

If the first byte of a 10-bit address matches the contents of I2CxADD<9:8> but the second byte of the 10-bit address does not match I2CxADD<7:0>, the slave module will return to an Idle state and ignore all bus activity until after the Stop condition.

## 19.7.3.8 ADDRESSES RESERVED FROM MASKING

Even when enabled, there are several addresses that are excluded in hardware from masking. For these addresses, an Acknowledge will not be issued independent of the mask setting. These addresses are listed in Table 19-3.

**Table 19-3: Reserved I<sup>2</sup>C-Bus Addresses<sup>(1)</sup>**

7-bit Address Mode:		
Slave Address	R/W Bit	Description
0000 000	0	General Call Address <sup>(1)</sup>
0000 000	1	Start Byte
0000 001	x	CBUS Address
0000 010	x	Reserved
0000 011	x	Reserved
0000 1xx	x	HS Mode Master Code
1111 1xx	x	Reserved
1111 0xx	x	10-Bit Slave Upper Byte <sup>(2)</sup>

**Note 1:** Address will be Acknowledged only if GCEN = 1.

**2:** Match on this address can only occur as the upper byte in the 10-Bit Addressing mode.

## 19.7.4 Receiving Data From a Master Device

When the  $\overline{R/W}$  status bit of the device address byte is zero and an address match occurs, the R/W status bit (I2CxSTAT<2>) is cleared. The slave module enters a state waiting for data to be sent by the master. After the device address byte, the contents of the data byte are defined by the system protocol and are only received by the slave module.

The slave module shifts eight bits into the I2CxRSR register. On the falling edge of the eighth clock (SCLx), the following events occur:

1. The module begins to generate an  $\overline{ACK}$  or NACK.
2. The RBF status bit is set to indicate received data.
3. The I2CxRSR register byte is transferred to the I2CxRCV register for access by the software.
4. The D/A status bit is set.
5. A slave interrupt is generated. Software can check the status of the I2CxSTAT register to determine the cause of the event and then clear the SI2CxIF interrupt flag.
6. The module waits for the next data byte.

## 19.7.4.1 ACKNOWLEDGE GENERATION

Normally, the slave module acknowledges all received bytes by sending an  $\overline{\text{ACK}}$  on the ninth SCLx clock. If the receive buffer is overrun, the slave module does not generate this ACK. Overrun is indicated if either (or both) of the following occur:

1. The buffer full bit, RBF (I2CxSTAT<1>), was set before the transfer was received.
2. The overflow bit, I2COV (I2CxSTAT<6>), was set before the transfer was received.

Table 19-4 shows what happens when a data transfer byte is received, given the status of the RBF and I2COV status bits. If the RBF status bit is already set when the slave module attempts to transfer to the I2CxRCV register, the transfer does not occur but the interrupt is generated and the I2COV status bit is set. If both the RBF and I2COV status bits are set, the slave module acts similarly. The shaded cells show the condition where software did not properly clear the overflow condition.

Reading the I2CxRCV register clears the RBF status bit. The I2COV status bit is cleared by writing to a '0' through software.

**Table 19-4: Data Transfer Received Byte Actions**

Status Bits as Data Byte Received		Transfer I2CxRSR to I2CxRCV	Generate ACK	Generate SI2CxIF Interrupt (interrupt occurs if enabled)	Set RBF	Set I2COV
RBF	I2COV					
0	0	Yes	Yes	Yes	Yes	No change
1	0	No	No	Yes	No change	Yes
1	1	No	No	Yes	No change	Yes
0	1	Yes	No	Yes	Yes	No change

**Legend:** Shaded cells show state where the software did not properly clear the overflow condition.

## 19.7.4.2 WAIT STATES DURING SLAVE RECEPTIONS

When the slave module receives a data byte, the master can potentially begin sending the next byte immediately. This allows the software controlling the slave module nine SCLx clock periods to process the previously received byte. If this is not enough time, the slave software may want to generate a bus wait period.

The STREN bit (I2CxCON<6>) enables a bus wait to occur on slave receptions. When STREN = 1 at the falling edge of the ninth SCLx clock of a received byte, the slave module clears the SCLREL bit. Clearing the SCLREL bit causes the slave module to pull the SCLx line low, initiating a wait. The SCLx clock of the master and slave will synchronize, as shown in **19.6.2 “Master Clock Synchronization”**.

When the software is ready to resume reception, the software sets SCLREL. This causes the slave module to release the SCLx line, and the master resumes clocking.

## 19.7.4.3 EXAMPLE MESSAGES OF SLAVE RECEPTION

Receiving a slave message is an automatic process. The software handling the slave protocol uses the slave interrupt to synchronize to the events.

When the slave detects the valid address, the associated interrupt will notify the software to expect a message. On receive data, as each data byte transfers to the I2CxRCV register, an interrupt notifies the software to unload the buffer.

Figure 19-26 shows a simple receive message. Because it is a 7-bit address message, only one interrupt occurs for the address bytes. Then, interrupts occur for each of four data bytes. At an interrupt, the software may monitor the RBF,  $D/\bar{A}$  and  $R/\bar{W}$  status bits to determine the condition of the byte received.

Figure 19-27 shows a similar message using a 10-bit address. In this case, two bytes are required for the address.

Figure 19-28 shows a case where the software does not respond to the received byte and the buffer overruns. On reception of the second byte, the module will automatically NACK the master transmission. Generally, this causes the master to re-send the previous byte. The I2COV status bit indicates that the buffer has overrun. The I2CxRCV register buffer retains the contents of the first byte. On reception of the third byte, the buffer is still full, and again, the module will NACK the master. After this, the software finally reads the buffer. Reading the buffer will clear the RBF status bit; however, the I2COV status bit remains set. The software must clear the I2COV status bit. The next received byte is moved to the I2CxRCV register buffer and the module responds with an ACK.

Figure 19-29 highlights clock stretching while receiving data. In the previous examples, STREN = 0, which disables clock stretching on receive messages. In this example, the software sets STREN to enable clock stretching. When STREN = 1, the module will automatically clock stretch after each received data byte, allowing the software more time to move the data from the buffer. If RBF = 1 at the falling edge of the ninth clock, the module automatically clears the SCLREL bit and pulls the SCLx bus line low. As shown with the second received data byte, if the software can read the buffer and clear the RBF status bit before the falling edge of the ninth clock, the clock stretching will not occur. The software can also suspend the bus at any time. By clearing the SCLREL bit, the module pulls the SCLx line low after it detects the bus SCLx low. The SCLx line remains low, suspending transactions on the bus until the SCLREL bit is set.

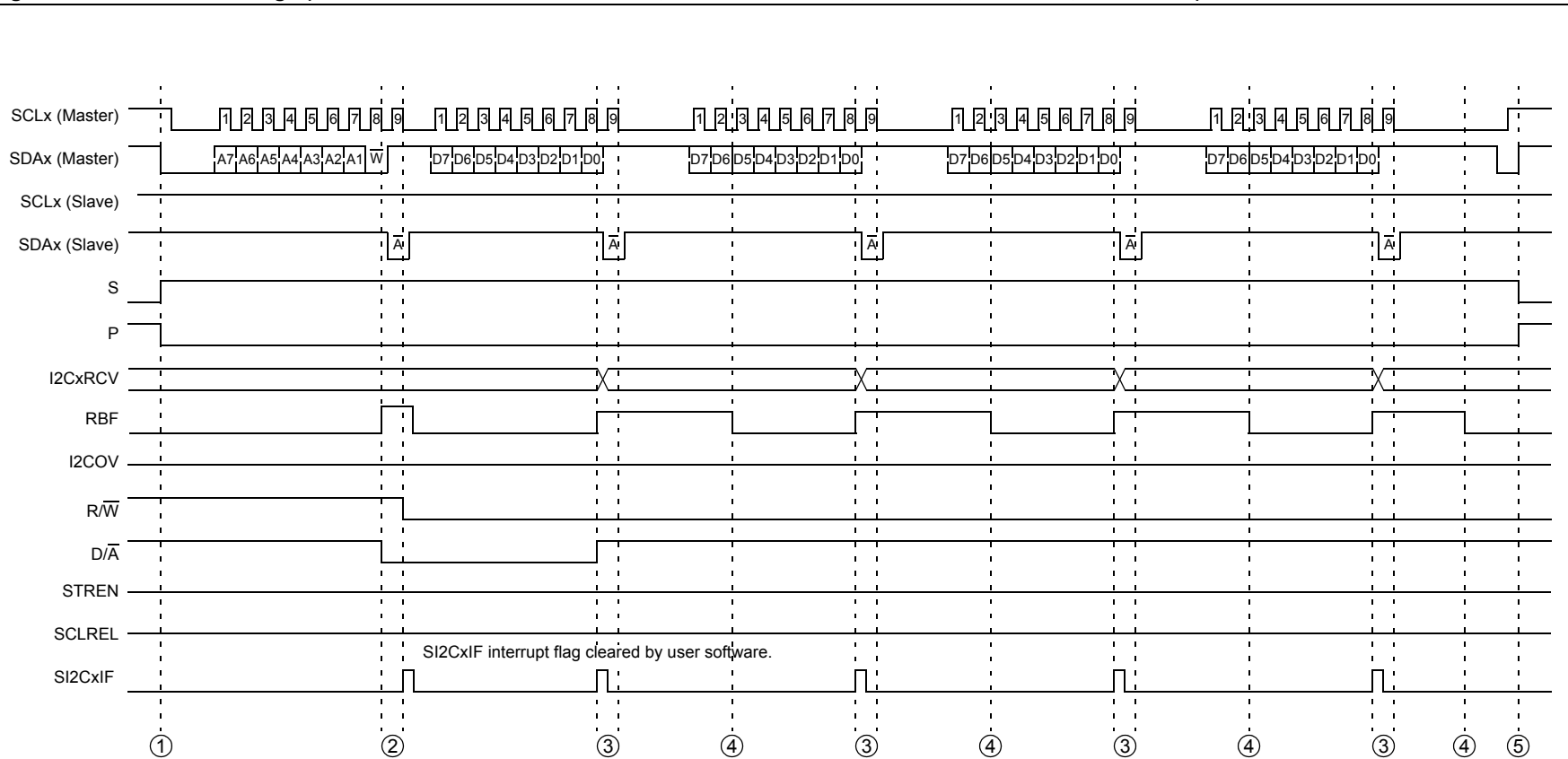
**Figure 19-26: Slave Message (Write Data to Slave: 7-Bit Address; Address Matches; A10M = 0; GCEN = 0; IPMIEN = 0)**

- ① Slave recognizes Start event; S and P status bits set/clear accordingly.
- ② Slave receives address byte. Address matches. Slave Acknowledges and generates interrupt. Address byte is moved to I2CxRCV register and must be read by user software to prevent buffer overflow.
- ③ Next received byte is message data. Byte moved to I2CxRCV register sets the RBF status bit. Slave generates interrupt. Slave Acknowledges reception.
- ④ Software reads I2CxRCV register. RBF status bit clears.
- ⑤ Slave recognizes Stop event; S and P status bits set/clear accordingly.

Figure 19-27: Slave Message (Write Data to Slave: 10-Bit Address; Address Matches; A10M = 1; GCEN = 0; IPMIEN = 0)

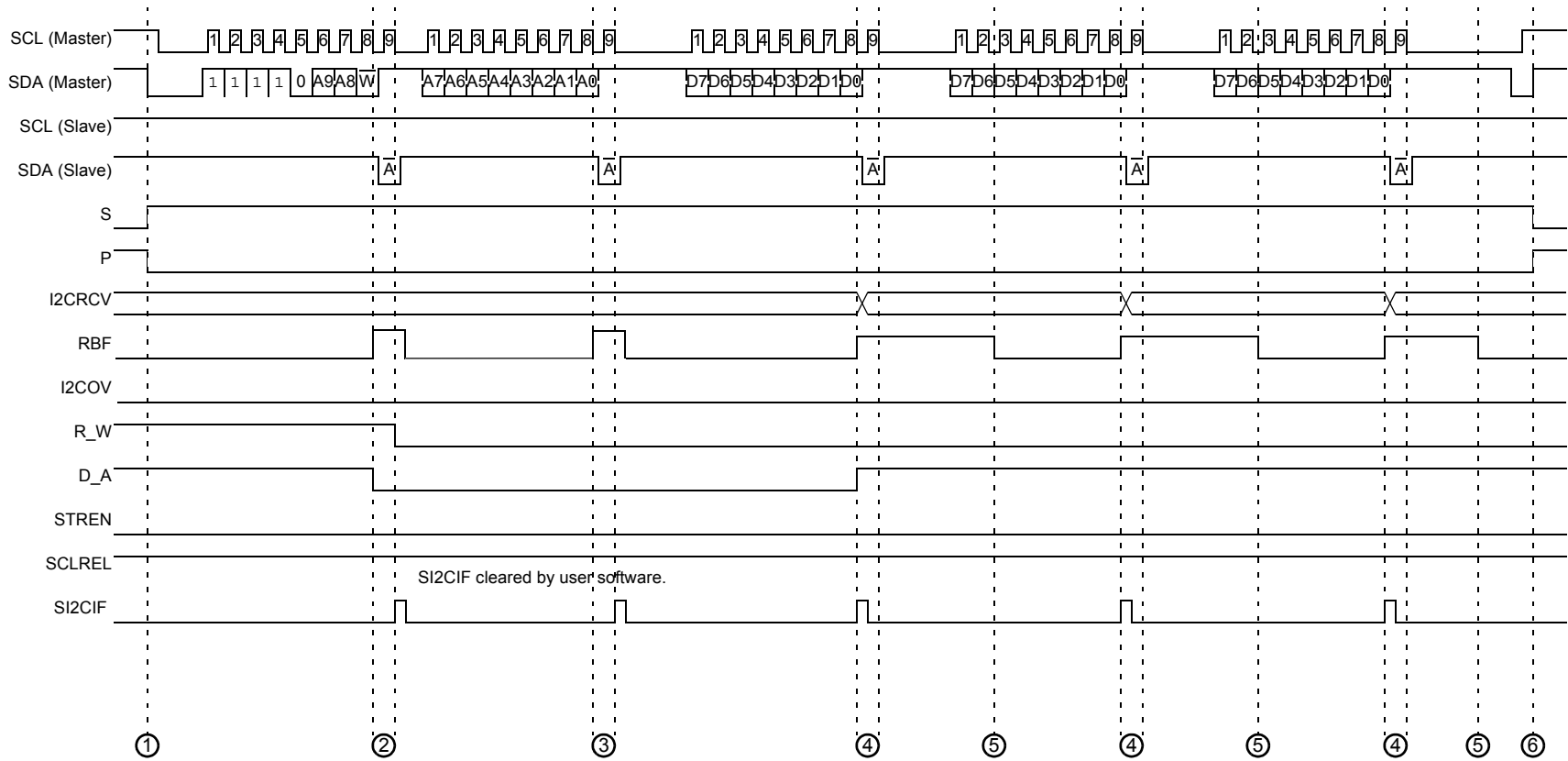

- ① - Slave recognizes Start event, S and P bits set/clear accordingly.
- ② - Slave receives address byte. High order address matches. Slave Acknowledges and generates interrupt. Address byte is moved to I2CRCV register and is read by user software to prevent buffer overflow.
- ③ - Slave receives address byte. Low order address matches. Slave Acknowledges and generates interrupt. Address byte is moved to I2CRCV register and is read by user software to prevent buffer overflow.
- ④ - Next received byte is message data. Byte moved to I2CRCV register, sets RBF. Slave Acknowledges and generates interrupt.
- ⑤ - Software reads I2CRCV register. RBF bit clears.
- ⑥ - Slave recognizes Stop event, S and P bits set/clear accordingly.

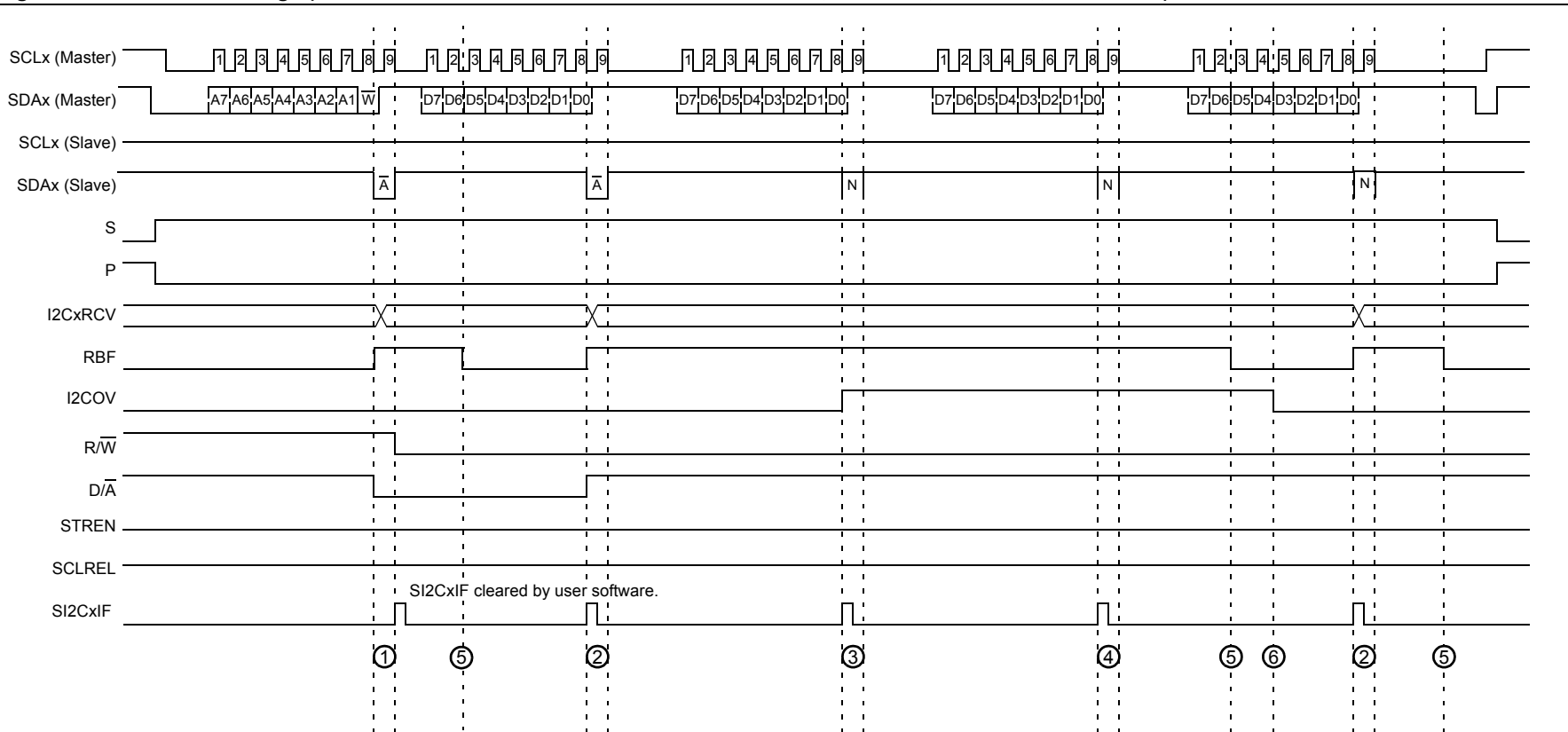
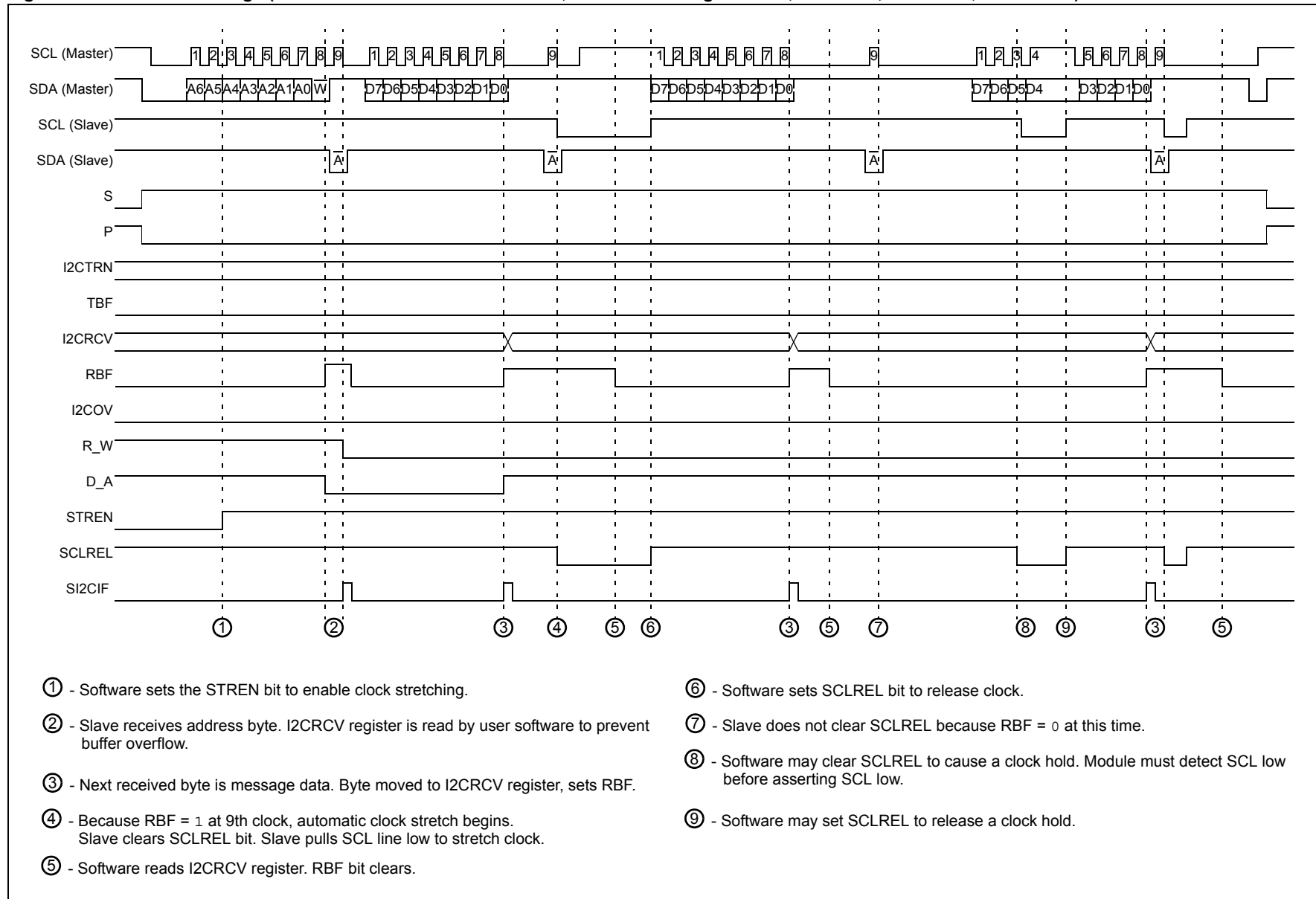

**Figure 19-28: Slave Message (Write Data to Slave: 7-Bit Address; Buffer Overrun; A10M = 0; GCEN = 0; IPMIEN = 0)**

- ① - Slave receives address byte. Address matches. Slave generates interrupt. Address byte is moved to I2CxRCV register and must be read by user software to prevent buffer overflow.
- ② - Next received byte is message data. Byte moved to I2CxRCV register, sets RBF. Slave generates interrupt. Slave Acknowledges reception.
- ③ - Next byte received before I2CxRCV read by software. I2CxRCV register unchanged. I2COV overflow bit set. Slave generates interrupt. Slave sends NACK for reception.

- ④ - Next byte also received before I2CxRCV read by software. I2CxRCV register unchanged. Slave generates interrupt. Slave sends NACK for reception. The master state machine should not be programmed to send another byte after receiving a NACK in this manner. Instead, it should abort the transmission with a stop condition or send a repeated start condition and attempt to retransmit the data.
- ⑤ - Software reads I2CxRCV register. RBF bit clears.
- ⑥ - Software clears I2COV bit. Reception will still not be able to proceed normally until the module sees a stop/repeated start bit. If neither of these conditions is met, an additional transmission will be received correctly, but send a NACK and set the I2COV bit again.

Figure 19-29: Slave Message (Write Data to Slave: 7-Bit Address; Clock Stretching Enabled; A10M = 0; GCEN = 0; IPMIEN = 0)



## 19.7.5 Sending Data to a Master Device

When the  $\overline{R/W}$  status bit of the incoming device address byte is '1' and an address match occurs, the  $\overline{R/W}$  status bit (I2CxSTAT<2>) is set. At this point, the master device is expecting the slave to respond by sending a byte of data. The contents of the byte are defined by the system protocol and are only transmitted by the slave module.

When the interrupt from the address detection occurs, the software can write a byte to the I2CxTRN register to start the data transmission.

The slave module sets the TBF status bit. The eight data bits are shifted out on the falling edge of the SCLx input. This ensures that the SDAx signal is valid during the SCLx high time. When all eight bits have been shifted out, the TBF status bit is cleared.

The slave module detects the Acknowledge from the master-receiver on the rising edge of the ninth SCLx clock.

If the SDAx line is low, indicating an Acknowledge ( $\overline{ACK}$ ), the master is expecting more data and the message is not complete. The module generates a slave interrupt, and the ACKSTAT status bit can be inspected to determine whether more data is being requested.

A slave interrupt is generated on the falling edge of the ninth SCLx clock. Software must check the status of the I2CxSTAT register and clear the SI2CxIF interrupt flag.

If the SDAx line is high, indicating a Not Acknowledge (NACK), the data transfer is complete. The slave module resets and generates an interrupt, and it waits for detection of the next Start bit.

### 19.7.5.1 WAIT STATES DURING SLAVE TRANSMISSIONS

During a slave transmission message, the master expects return data immediately after detection of the valid address with  $R/W = 1$ . Because of this, the slave module automatically generates a bus wait whenever the slave returns data.

The automatic wait occurs at the falling edge of the ninth SCLx clock of a valid device address byte or transmitted byte Acknowledged by the master, indicating expectation of more transmit data.

The slave module clears the SCLREL bit. Clearing the SCLREL bit causes the slave module to pull the SCLx line low, initiating a wait. The SCLx clock of the master and slave will synchronize as shown in **19.6.2 “Master Clock Synchronization”**.

When the software loads the I2CxTRN register and is ready to resume transmission, the software sets SCLREL. This causes the slave module to release the SCLx line and the master resumes clocking.

### 19.7.5.2 EXAMPLE MESSAGES OF SLAVE TRANSMISSION

Slave transmissions for 7-bit address messages are shown in Figure 19-30. When the address matches and the  $\overline{R/W}$  status bit of the address indicates a slave transmission, the module automatically initiates clock stretching by clearing the SCLREL bit and generates an interrupt to indicate a response byte is required. The software writes the response byte into the I2CxTRN register. As the transmission completes, the master responds with an Acknowledge. If the master replies with an  $\overline{ACK}$ , the master expects more data and the module again clears the SCLREL bit and generates another interrupt. If the master responds with a NACK, no more data is required and the module will not stretch the clock nor generate an interrupt.

Slave transmissions for 10-bit address messages require the slave to first recognize a 10-bit address. Because the master must send two bytes for the address, the  $\overline{R/W}$  status bit in the first byte of the address specifies a write. To change the message to a read, the master sends a Repeated Start and repeats the first byte of the address with the  $\overline{R/W}$  status bit specifying a read. At this point, the slave transmission begins as shown in Figure 19-31.

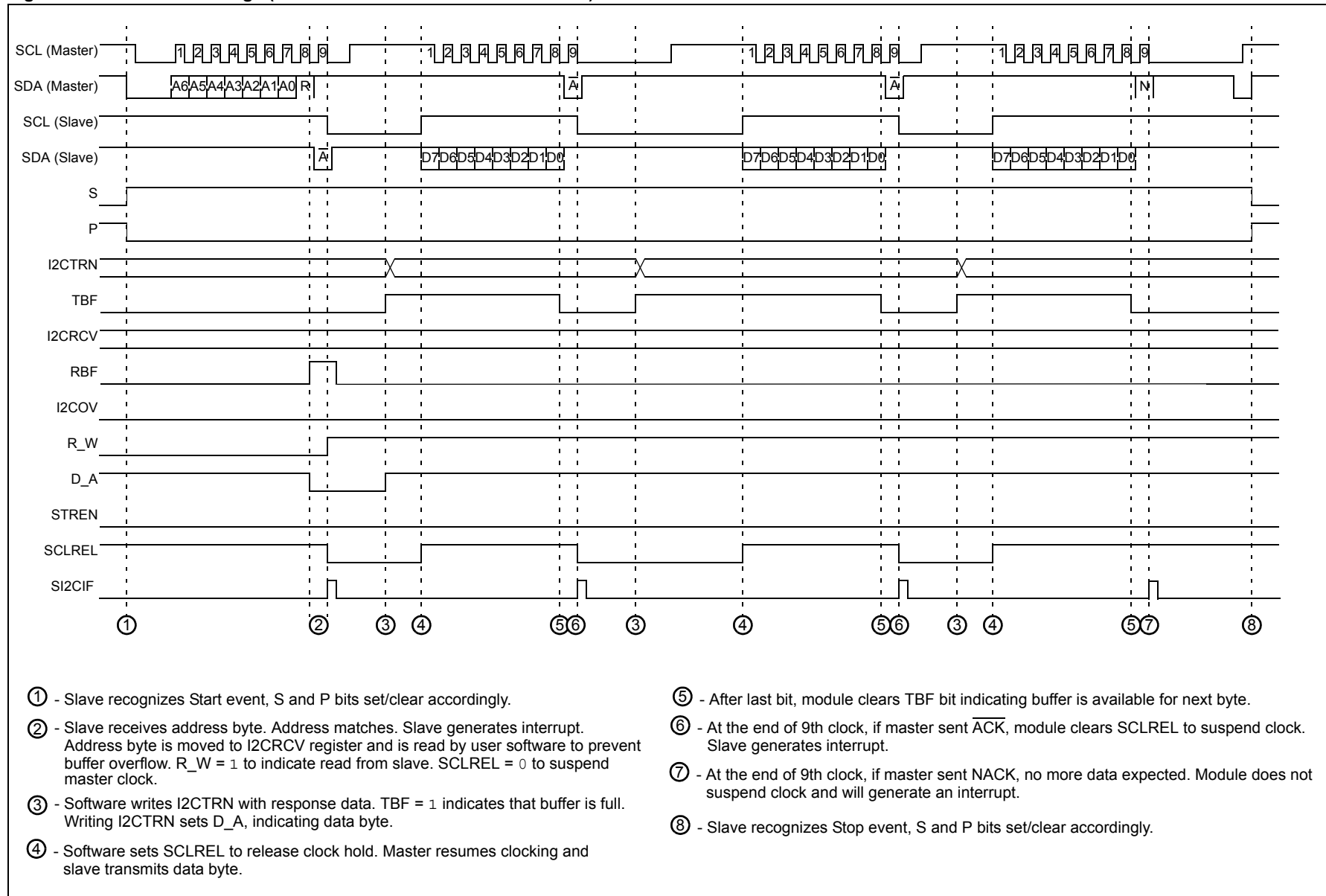
**Figure 19-30: Slave Message (Read Data From Slave: 7-Bit Address)**

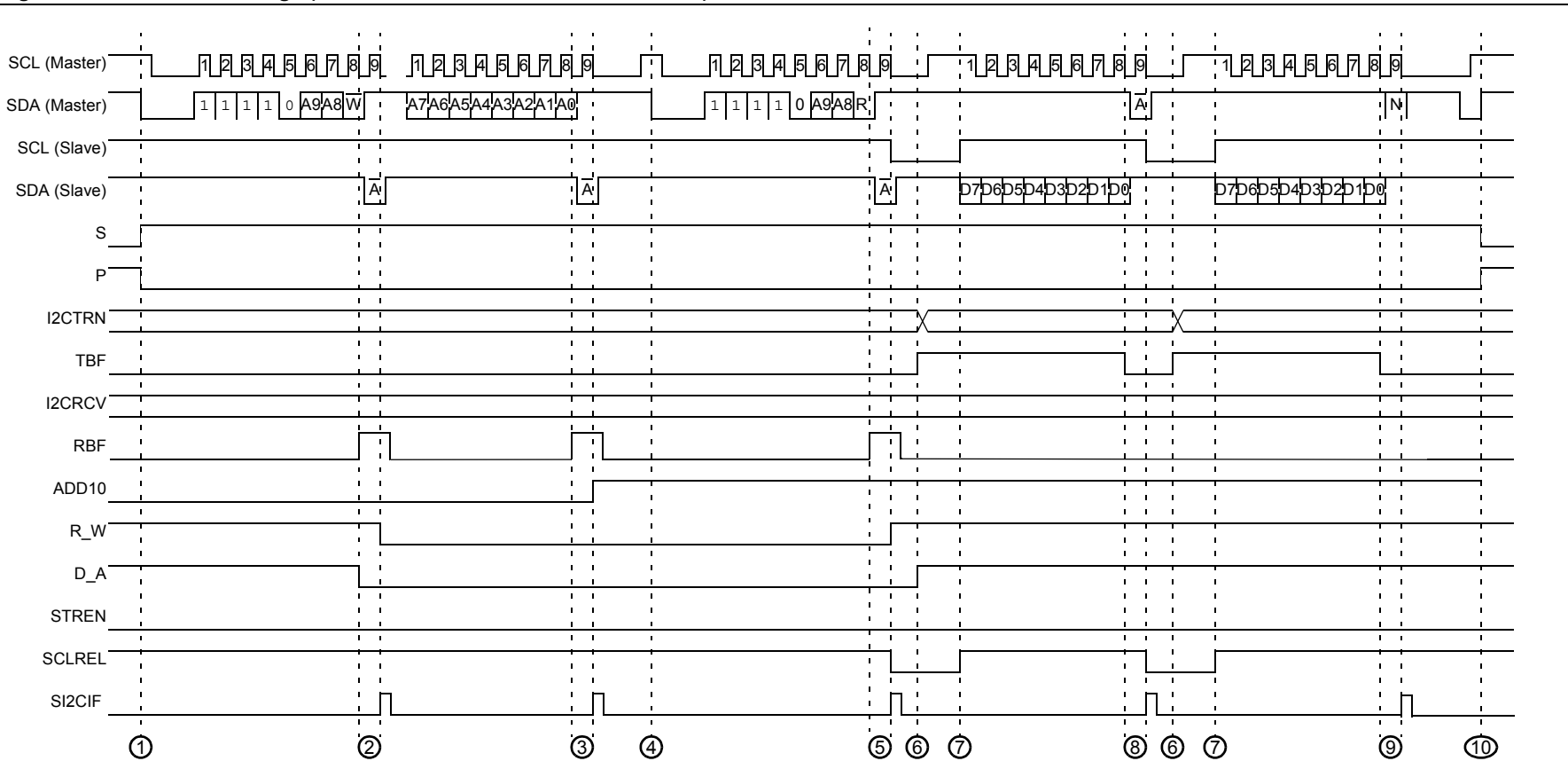
**Figure 19-31: Slave Message (Read Data From Slave: 10-Bit Address)**

- ① - Slave recognizes Start event, S and P bits set/clear accordingly.
- ② - Slave receives first address byte. Write indicated. Slave Acknowledges and generates interrupt. User software reads I2CRCV register.
- ③ - Slave receives address byte. Address matches. Slave Acknowledges and generates interrupt. User software reads I2CRCV register.
- ④ - Master sends a Repeated Start to redirect the message.
- ⑤ - Slave receives resend of first address byte. User software reads I2CRCV register. Read indicated. Slave suspends clock.
- ⑥ - Software writes I2CTRN with response data.
- ⑦ - Software sets SCLREL to release clock hold. Master resumes clocking and slave transmits data byte.
- ⑧ - At the end of 9th clock, if master sent  $\overline{\text{ACK}}$ , module clears SCLREL to suspend clock. Slave generates interrupt.
- ⑨ - At the end of 9th clock, if master sent NACK, no more data expected. Module does not suspend clock or generate interrupt.
- ⑩ - Slave recognizes Stop event, S and P bits set/clear accordingly.

## 19.8 CONNECTION CONSIDERATIONS FOR I<sup>2</sup>C-BUS

Because the I<sup>2</sup>C-bus is a wired AND bus connection, pull-up resistors on the bus are required, shown as R<sub>P</sub> in Figure 19-32. Series resistors, shown as R<sub>S</sub>, are optional and used to improve ESD susceptibility. The values of resistors, R<sub>P</sub> and R<sub>S</sub>, depend on the following parameters:

- Supply voltage
- Bus capacitance
- Number of connected devices (input current + leakage current)
- Input level selection (I<sup>2</sup>C or SMBus)

Because the device must be able to pull the bus low against R<sub>P</sub>, current drawn by R<sub>P</sub> must be greater than the I/O pin minimum sink current, I<sub>OL</sub> of 6.6 mA at V<sub>OLMAX</sub> = 0.4V, for the device output stage. For example, with a supply voltage of V<sub>DD</sub> = 3V + 10%:

### Equation 19-2:

$$R_{P\text{MIN}} = (V_{DD\text{MAX}} - V_{OL\text{MAX}}) / I_{OL} = (3.3\text{V} - 0.6\text{V}) / 8.5\text{ mA} = 439\Omega$$

In a 400 kHz system, a minimum rise time specification of 300 ns exists; in a 100 kHz system, the specification is 1000 ns. Because R<sub>P</sub> must pull the bus up against the total capacitance, C<sub>B</sub>, with a maximum rise time of 300 ns to (V<sub>DD</sub> - 0.7V), the maximum resistance for the pull-up (R<sub>PMAX</sub>) must be less than:

### Equation 19-3:

$$-t_R / (C_B * (\ln(1 - (V_{DD\text{MAX}} - V_{IL\text{MAX}}) / V_{DD\text{MAX}}))) = -300\text{ ns} / (100\text{ pF} * \ln(1 - (0.99 - 3.3) / 3.3)), \text{ or } 2.5\text{ k}\Omega$$

The maximum value for R<sub>S</sub> is determined by the desired noise margin for the low level. R<sub>S</sub> cannot drop enough voltage to make the device V<sub>OL</sub> plus the voltage across R<sub>S</sub> more than the maximum V<sub>IL</sub>. Mathematically:

### Equation 19-4:

$$R_{S\text{MAX}} = (V_{IL\text{MAX}} - V_{OL\text{MAX}}) / I_{OL\text{MAX}} = (0.3 V_{DD} - 0.4) / 6.6\text{ mA} = 89\Omega$$

The SCL<sub>x</sub> clock input must have a minimum high and low time for proper operation. The high and low times of the I<sup>2</sup>C-bus specification, as well as the requirements of the I<sup>2</sup>C module, are shown in the “Electrical Characteristics” section of the specific data sheet.

**Figure 19-32: Sample Device Configuration for I<sup>2</sup>C™-Bus**

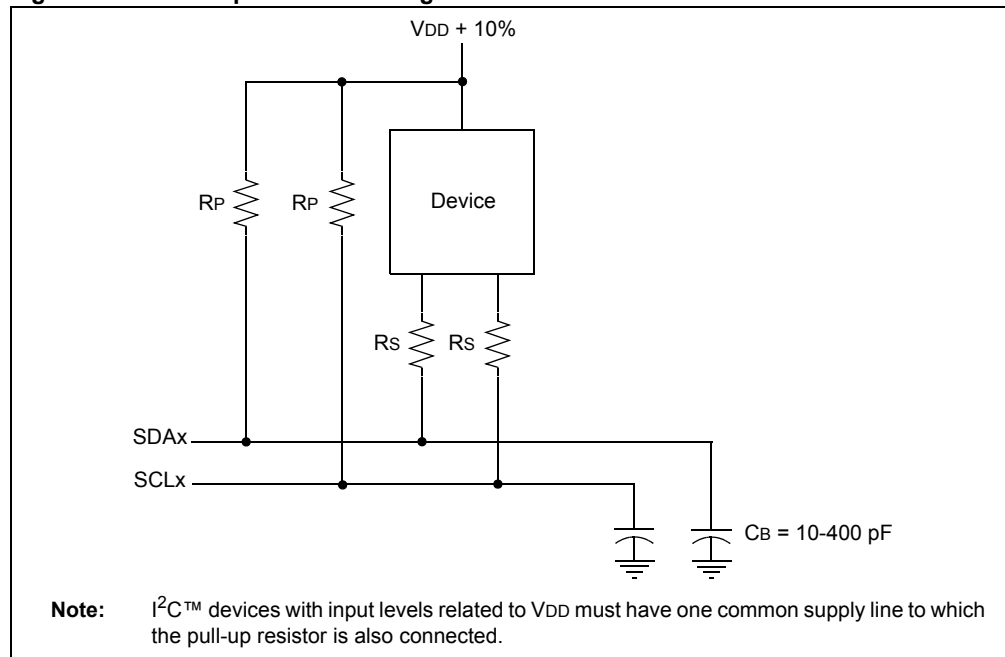

## 19.8.1 Integrated Signal Conditioning

The SCLx and SDAx pins have an input glitch filter. The I<sup>2</sup>C-bus requires this filter in both the 100 kHz and 400 kHz systems.

When operating on a 400 kHz bus, the I<sup>2</sup>C-bus specification requires a slew rate control of the device pin output. This slew rate control is integrated into the device. If the DISSLW bit (I2CxCON<9>) is cleared, the slew rate control is active. For other bus speeds, the I<sup>2</sup>C-bus specification does not require slew rate control and the DISSLW bit should be set.

Some system implementations of I<sup>2</sup>C busses require different input levels for VILMAX and VIHMIN. In a normal I<sup>2</sup>C system, VILMAX is 0.3 VDD; VIHMIN is 0.7 VDD. By contrast, in an SMBus (System Management Bus) system, VILMAX is set at 0.8V, while VIHMIN is set at 2.1V.

The SMEN bit (I2CxCON<8>) controls the input levels. Setting SMEN (= 1) changes the input levels to SMBus specifications.

## 19.9 MODULE OPERATION DURING PWRSAV INSTRUCTION

### 19.9.1 Sleep Mode in Slave Mode

The module will continue full operation if Sleep mode is entered while the module is configured in Slave mode. Since all bit shifting is done with reference to the external SCL signal, all data transmit and receive operations will continue. The module is then required to assert an asynchronous interrupt as needed.

### 19.9.2 Sleep Mode in Master Mode

If Sleep occurs in the middle of a master transmission, and the state machine is partially into a transmission as the clocks stop, the behavior of the module will be undefined. Similarly, if Sleep occurs in the middle of a master reception, the module behavior will also be undefined. The transmitter and receiver will stop at Sleep when in Master mode. Register contents are not affected by going into Sleep mode or coming out of Sleep mode; there is no automatic way to prevent Sleep entry if a transmission or reception is pending. The user software must synchronize Sleep entry with I<sup>2</sup>C operation to avoid undefined module behavior.

### 19.9.3 When the Device Enters Idle Mode

When the device executes a PWRSAV 1 instruction, the device enters Idle mode. The module enters a power-saving state in Idle mode, depending on the I2CSIDL bit (I2CxCON<13>). If I2CSIDL = 1, the module enters the Power-Saving mode similar to actions while entering Sleep mode. If I2CSIDL = 0, the module does not enter a Power-Saving mode and continues to operate normally.

## 19.10 PERIPHERAL MODULE DISABLE (PMD) REGISTERS

The Peripheral Module Disable (PMDx) registers provide a method to disable the I<sup>2</sup>C modules by stopping all clock sources supplied to that module. When a peripheral is disabled via the appropriate PMDx control bit, the peripheral is in a minimum power consumption state. The control and status registers associated with the peripheral are also disabled, so writes to those registers will have no effect and read values will be invalid. A peripheral module is only enabled if the I2CxMD bit in the PMDx register is cleared.

## 19.11 EFFECTS OF A RESET

A Reset disables the I<sup>2</sup>C module and terminates any active or pending message activity. See the I2CxCON and I2CxSTAT register definitions for the Reset conditions of those registers.

**Note:** In this discussion, 'Idle' refers to the CPU power-saving state. The lower case 'idle' refers to the time when the I<sup>2</sup>C module is not transferring data on the bus.

## 19.12 REGISTER MAPS

A summary of the registers associated with the PIC24H I<sup>2</sup>C module is provided in Table 19-5.

**Table 19-5: I<sup>2</sup>Cx Register Map**

File Name	Bit 15	Bit 14	Bit 13	Bit 12	Bit 11	Bit 10	Bit 9	Bit 8	Bit 7	Bit 6	Bit 5	Bit 4	Bit 3	Bit 2	Bit 1	Bit 0	All Resets
I2CxRCV	—	—	—	—	—	—	—	—	Receive Register								0000
I2CxTRN	—	—	—	—	—	—	—	—	Transmit Register								00FF
I2CxBRG	—	—	—	—	—	—	—	Baud Rate Generator								0000	
I2CxCON	I2CEN	—	I2CSIDL	SCLREL	IPMIEN	A10M	DISSLW	SMEN	GCEN	STREN	ACKDT	ACKEN	RCEN	PEN	RSEN	SEN	1000
I2CxSTAT	ACKSTAT	TRSTAT	—	—	—	BCL	GCSTAT	ADD10	IWCOL	I2COV	D/Ā	P	S	R/W	RBF	TBF	0000
I2CxADD	—	—	—	—	—	—	Address Register								0000		
I2CxMSK	—	—	—	—	—	—	Address Mask								0000		

**Legend:** — = unimplemented, read as '0'. Reset values are shown in hexadecimal.



## 19.13 DESIGN TIPS

**Question 1:** *I'm operating as a bus master and transmitting data. Why do slave and receive interrupts keep occurring at the same time?*

**Answer:** The master and slave circuits are independent. The slave module will receive events from the bus sent by the master.

**Question 2:** *I'm operating as a slave and I write data to the I2CxTRN register. Why isn't the data being transmitted?*

**Answer:** The slave enters an automatic wait when preparing to transmit. Ensure that you set the SCLREL bit to release the I<sup>2</sup>C clock.

**Question 3:** *How do I tell what state the master module is in?*

**Answer:** Looking at the condition of the SEN, RSEN, PEN, RCEN, ACKEN and TRSTAT bits will indicate the state of the master module. If all bits are '0', the module is Idle.

**Question 4:** *Operating as a slave, I receive a byte while STREN = 0. What should the software do if it cannot process the byte before the next one is received?*

**Answer:** Because STREN was '0', the module did not generate an automatic wait on the received byte. However, the software may, at any time during the message, set STREN and then clear SCLREL. This will cause a wait on the next opportunity to synchronize the SCLx clock.

**Question 5:** *My I<sup>2</sup>C system is a multi-master system. Why are my messages being corrupted when I attempt to send them?*

**Answer:** In a multi-master system, other masters may cause bus collisions. In the Interrupt Service Routine for the master, check the BCL status bit to ensure that the operation completed without a collision. If a collision is detected, the message must be re-sent from the beginning.

**Question 6:** *My I<sup>2</sup>C system is a multi-master system. How can I tell when it is OK to begin a message?*

**Answer:** Look at the S status bit. If S = 0, the bus is Idle.

**Question 7:** *I tried to send a Start condition on the bus, then transmit a byte by writing to the I2CxTRN register. The byte did not get transmitted. Why?*

**Answer:** You must wait for each event on the I<sup>2</sup>C-bus to complete before starting the next one. In this case, you should poll the SEN bit to determine when the Start event completed or wait for the master I<sup>2</sup>C interrupt before data is written to the I2CxTRN register.

## 19.14 RELATED APPLICATION NOTES

This section lists application notes that are related to this section of the manual. These application notes may not be written specifically for the PIC24H device family, but the concepts are pertinent and could be used with modification and possible limitations. The current application notes related to the Inter-Integrated Circuit™ (I<sup>2</sup>C™) module include the following:

<b>Title</b>	<b>Application Note #</b>
Use of the SSP Module in the I <sup>2</sup> C™ Multi-Master Environment	AN578
Using the PICmicro® SSP for Slave I <sup>2</sup> C™ Communication	AN734
Using the PICmicro® MSSP Module for Master I <sup>2</sup> C™ Communications	AN735
An I <sup>2</sup> C™ Network Protocol for Environmental Monitoring	AN736

<b>Note:</b> Please visit the Microchip web site ( <a href="http://www.microchip.com">www.microchip.com</a> ) for additional application notes and code examples for the PIC24H family of devices.
--

## 19.15 REVISION HISTORY

### Revision A (February 2007)

This is the initial released revision of this document.

### Revision B (August 2008)

This revision includes the following corrections and updates:

- Updated bit definitions for the ACKSTAT bit (I2CxSTAT<15>) and the D/Ā bit (I2CxSTAT<5>) in Register 19-2.
- Updated the I2CBRG denominator from 1,111,111 to 10,000,000 in Equation 19-1.
- Updated the I<sup>2</sup>C clock rate values in Table 19-1, removed the table notes and added a general note just after the table.
- Updated the last two paragraphs in **19.3 “Control and Status Registers”** to clarify the shift of matching address bytes in the I2CxRSR register to the I2CxRCV register.
- Updated **19.4 “Enabling I<sup>2</sup>C Operation”** to clarify that the master function is enabled when the SEN bit is set, and when data is loaded into the I2CxTRN register.
- Several sections were updated to clarify NACK status in Slave mode. The affected sections are:
  - **19.4.2 “I<sup>2</sup>C Interrupts”**
  - **19.7.5 “Sending Data to a Master Device”**
  - Figure 19-28 through Figure 19-31
- The IPMIEN bit was incorrectly described as the Intelligent *Peripheral* Management Interface Enable bit. All occurrences have been updated to Intelligent *Platform* Management Interface bit.
- Updated **19.9.2 “Sleep Mode in Master Mode”** to clarify what occurs when entering Sleep mode while transmitting.
- Updated the Slave Message RBF status bit information in Figure 19-26 through Figure 19-31.

Additional minor corrections such as language and formatting updates are incorporated throughout the document.

NOTES: