

Allow the PICmicro™ to Control Its Oscillator Frequency

Author: Robert Corkery
Vicor Corp.
Andover, Ma.
bcorkery@vicr.com

INTRODUCTION

This application allows the processor to run at low frequency (using less power), but it can increase its oscillator frequency for more intensive operations.

Using a controller with an external RC oscillator, the PICmicro™ can change its oscillator speed by setting the I/O pin to low, which turns on Q1 and effectively puts R2 in parallel with R1.

SCHEMATIC

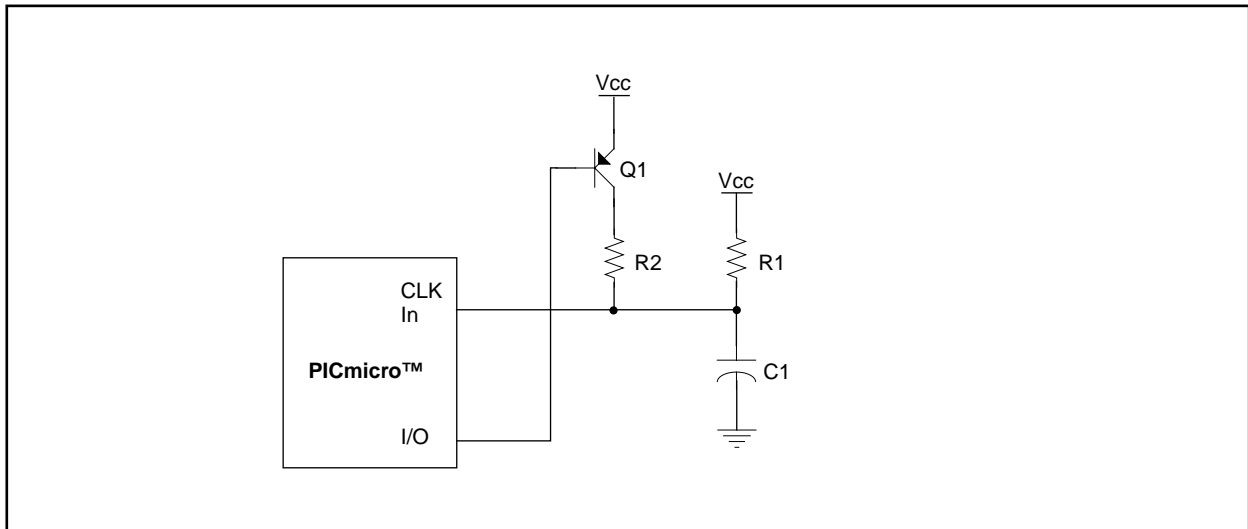

Microchip Technology Incorporated, has been granted a nonexclusive, worldwide license to reproduce, publish and distribute all submitted materials, in either original or edited form. The author has affirmed that this work is an original, unpublished work and that he/she owns all rights to such work. All property rights, such as patents, copyrights and trademarks remain with author.

Simple Circuit

NOTES: