

## LCD Biasing and Contrast Control Methods

Author: Naveen Raj  
Microchip Technology Inc.

### INTRODUCTION

This Application Note provides methods that can be used to provide biasing voltages for Liquid Crystal displays. This document covers most of the biasing methods used in the PIC® microcontrollers with an LCD controller.

### LCD TYPES

LCD types and LCD waveforms determine the type of biasing that is required. There are different kinds of LCD biasing, based on the construction.

There are two electrodes where the LCD waveforms are driven; they are called SEGMENTS (SEGs) and COMMONS (COMs). The LCD requires an AC waveform to be applied between these electrodes.

Based on the number of SEGMENT and COMMON electrodes, the LCDs can be classified in two basic types:

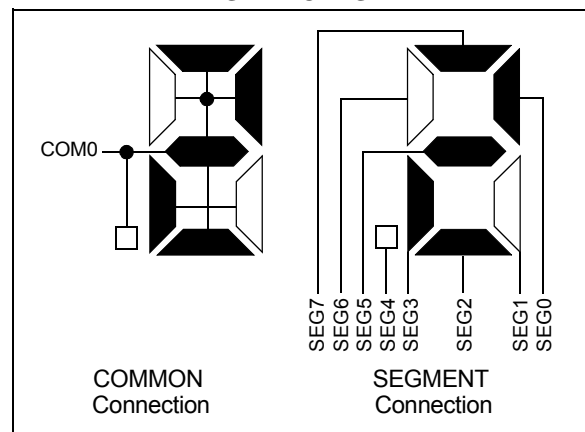
1. Static or Direct Drive
2. Multiplex Displays

### Static or Direct Drive LCD

The static waveform will have only one COMMON electrode and multiple SEGMENT electrodes. The number of pixels it can drive is the number of SEGMENTS on the LCD.

Figure 1 shows a static LCD configuration. There are 1 COMMON and 8 SEGMENTS, so the number of pixels that can be driven is the number of COMs, multiplied by the number of SEG pins, resulting in 8 pixels.

**FIGURE 1: COMMON AND SEGMENT CONNECTIONS FOR STATIC DISPLAY**

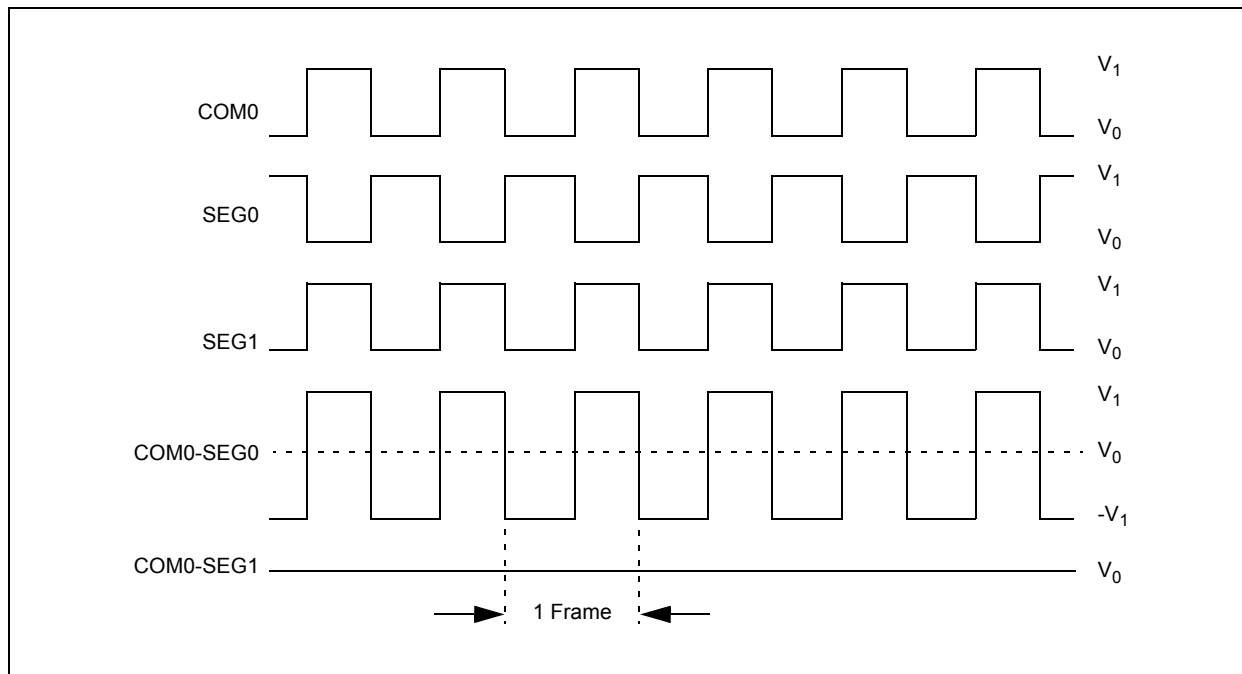


An AC voltage needs to be applied to the SEGMENT and COMMON. For a static display, there are only two levels for the voltage that are applied. These levels, which are driving the LCD, are called bias voltages. A static LCD wave will look like a square wave.

In Figure 1, SEG0 is on and SEG1 is off, and both are connected to COM0. The waveform in Figure 2 shows COM0, SEG0 and SEG1. It also shows the effective voltage between the SEG1 and SEG0, in respect to the COMMON.

# AN1428

FIGURE 2: COMMON AND SEGMENT WAVEFORM FOR STATIC DISPLAY



SEG0 is 180 degrees out of phase with COM0, so the effective voltage between the COM0/SEG0 will switch between  $-V_1$  and  $V_1$ . SEG1 is in phase with COM0 and the effective voltage between SEG1/COM1 is 0.

The advantage of this simple configuration is that it gives the best contrast. The disadvantage of this configuration is that the number of pixels that can be driven is limited to the number of SEGMENT pins. To drive more pixels, more pins are required and there will be more connections from the board to the LCD glass.

## Multiplex Display

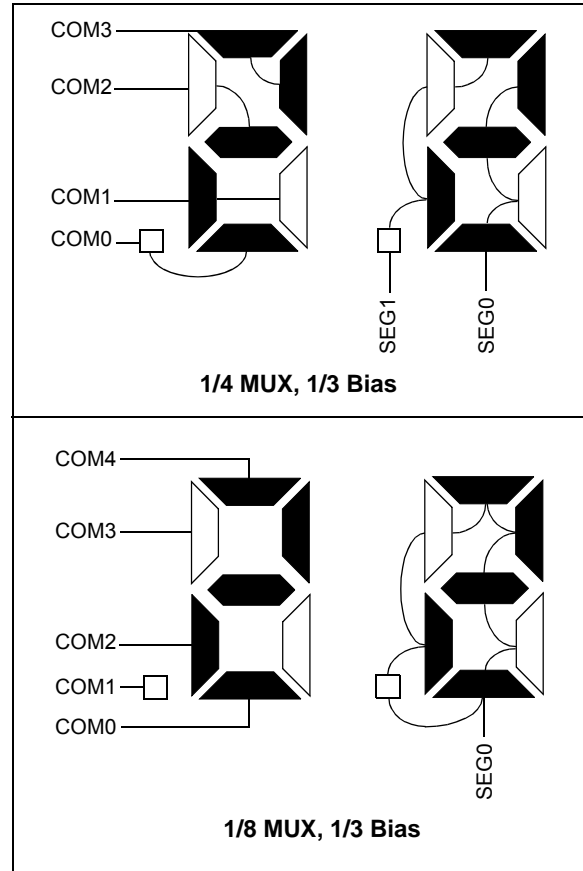
In the multiplex display, there will be more than one COMMON electrode, with multiple SEGMENT electrodes. Depending on the number of COMMON electrodes, the glass can be defined as 1/2 MUX, 1/3 MUX, 1/4 MUX, 1/8 MUX, etc.

Most of the Microchip LCD microcontrollers support both Static as well as Multiplex modes, up to 1/4 MUX. The newer devices, such as the PIC24FJ128GA310 family devices, support up to 1/8 MUX. In a multiplex display, the number of pixels that can be driven is calculated by multiplying the number of COMs, multiplied by the number of SEGs. For example, in the PIC24FJ128GA310 device, there are 8 COMMONS and 60 SEGMENTS. Therefore, the number of pixels that can be driven is  $60 \times 8 = 480$  pixels.

The LCD multiplexing possibilities of PIC MCUs, with the driver module configurable into 7 multiplex types, are as follows:

- 1/2 Multiplex (COM0 and COM1 are used)
- 1/3 Multiplex (COM0, COM1 and COM2 are used)
- 1/4 Multiplex (COM0, COM1, COM2 and COM3 are used)
- 1/5 Multiplex (COM0, COM1, COM2, COM3 and COM4 are used)
- 1/6 Multiplex (COM0, COM1, COM2, COM3, COM4 and COM5 are used)
- 1/7 Multiplex (COM0, COM1, COM2, COM3, COM4, COM5 and COM6 are used)
- 1/8 Multiplex (COM0, COM1, COM2, COM3, COM4, COM5, COM6 and COM7 are used)

**FIGURE 3: MULTIPLEXED LCD DISPLAY**

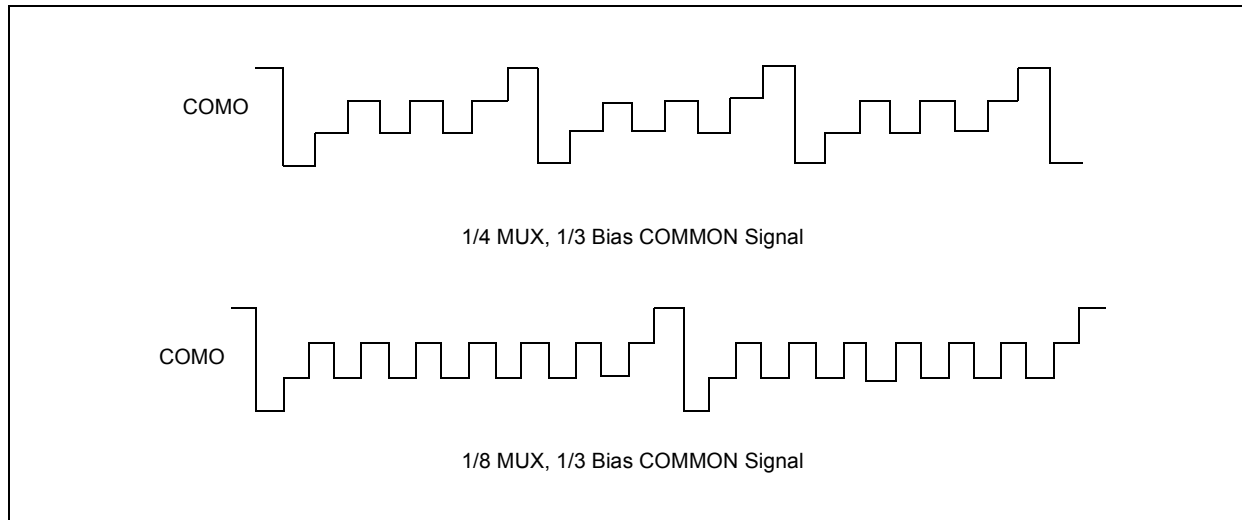


# AN1428

In a two COMMON multiplexed display, there are more than two levels of voltages required (bias voltage). Generating the bias voltages can be implemented in different ways, and has its own advantages and

disadvantages. Depending on the types of glass, there are two types of waveforms: Type A and Type B. The waveforms shown in [Figure 4](#) are Type A.

**FIGURE 4: MULTIPLEXED LCD DISPLAY WAVEFORM FOR COMMON**



The advantage of the multiplex waveform is that for the given number of SEGMENTS and COMMONs, the maximum pixels can be driven. For a given number of pixels, the number of traces on the PCB are the fewest. The disadvantage of this is that it will not provide the best contrast, as compared to a static display. Also, the multiplex display needs more than two voltage levels and necessitates the need to generate these mid-level bias voltages on the hardware, which is sometimes done inside the LCD controller.

## DISCRIMINATION RATIO

The discrimination ratio is what defines the contrast for an LCD. The higher the discrimination ratio, the better the LCD contrast. The discrimination ratio is the ratio of RMS voltage of an ON pixel divided by an OFF pixel. The static display has the highest discrimination ratio of infinity. As the multiplexing increases, the discrimination decreases. This is why the static display has the best contrast compared to the multiplex display. If the biasing levels are higher, that will also increase the discrimination ratio and thus, the contrast. Refer to the Application Note *AN658, "LCD Fundamentals Using PIC16C92X Microcontrollers"* for details regarding discrimination ratio calculation.

## FRAME FREQUENCY

The LCD frame frequency is the frequency at which the COMMON and SEGMENT outputs change. The frame frequency plays an important factor in the quality of the

displayed image. If the frequency is too low, the displayed image will flicker. If the frequency is too high, it will result in higher power consumption. The impact of frequency on the flicker is explained in more detail in the ["Clock Division"](#) section.

## CONTRAST

The contrast of the LCD is dependent on the amplitude of the LCD waveform and the available ambient light. The LCD manufacturer will provide the specifications at which the glass is to be operated. To get the best performance from the glass, the LCD should be operated at the specified voltage in the manufacturer's data sheet. Overdriving the glass can result in pixels that appear to be ON, when they are supposed to be OFF. This issue is also called "ghosting".

Ghosting can be caused by an insufficient discrimination ratio or when viewing the LCD at an incorrect viewing angle. The viewing angle is specified by the manufacturer. Ghosting can also occur if the LCD is operated at temperatures above the manufacturer's specification. Higher temperatures can cause LCD liquid crystal properties to change.

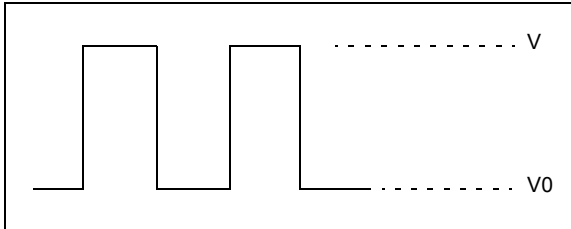
Faint pixels are caused by underdriving the glass. It can also be caused by operating at cold temperatures (where the liquid crystal response time increases). To achieve proper contrast, the correct voltage should be provided to the LCD. The contrast can be controlled through software by changing the amplitude of the LCD voltage waveform.

## BIAS LEVEL IN LCD

In the discussion of the LCD types, depending on the type and waveform, it is necessary to provide different voltage levels to generate the LCD waveform.

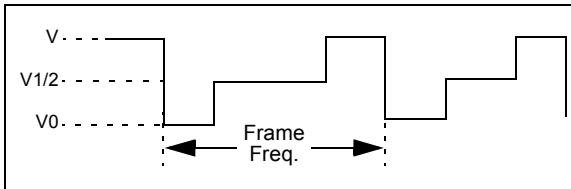
For a static display, it requires only two levels (see [Figure 5](#)).

**FIGURE 5: STATIC WAVEFORM**



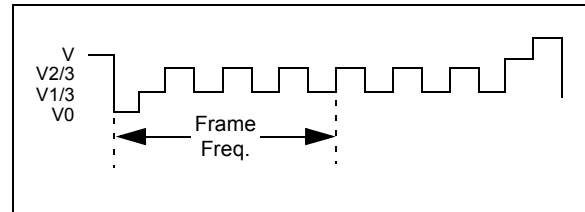
For a half bias, there are more than 2 voltage levels. If there is more than 1 COMMON (multiplexed), there will be more than two levels of voltage. [Figure 6](#) shows a 1/2 bias, 1/2 MUX waveform;  $V_{1/2}$  is between the  $V_0$  and  $V$ .

**FIGURE 6: 1/2 MUX, 1/2 BIAS WAVEFORM**



For a 1/3 bias waveform, there is one more level of voltage than the 1/2 bias to generate the required waveform. There are 4 levels:  $V_0$ ,  $V_{1/3}$ ,  $V_{2/3}$  and  $V$ . [Figure 7](#) shows a 1/3 bias waveform.

**FIGURE 7: 1/8 MUX, 1/3 BIAS WAVEFORM**



Usually, static levels are  $V_{SS}$  and  $V_{DD}$ . If there is any contrast control, the  $V_{DD}$  level voltage is varied by different methods. The LCD glass has a specification for the voltage that can be applied, which will be available in the data sheet provided by the LCD glass manufacturer.

# AN1428

## BIASING USING RESISTOR LADDER

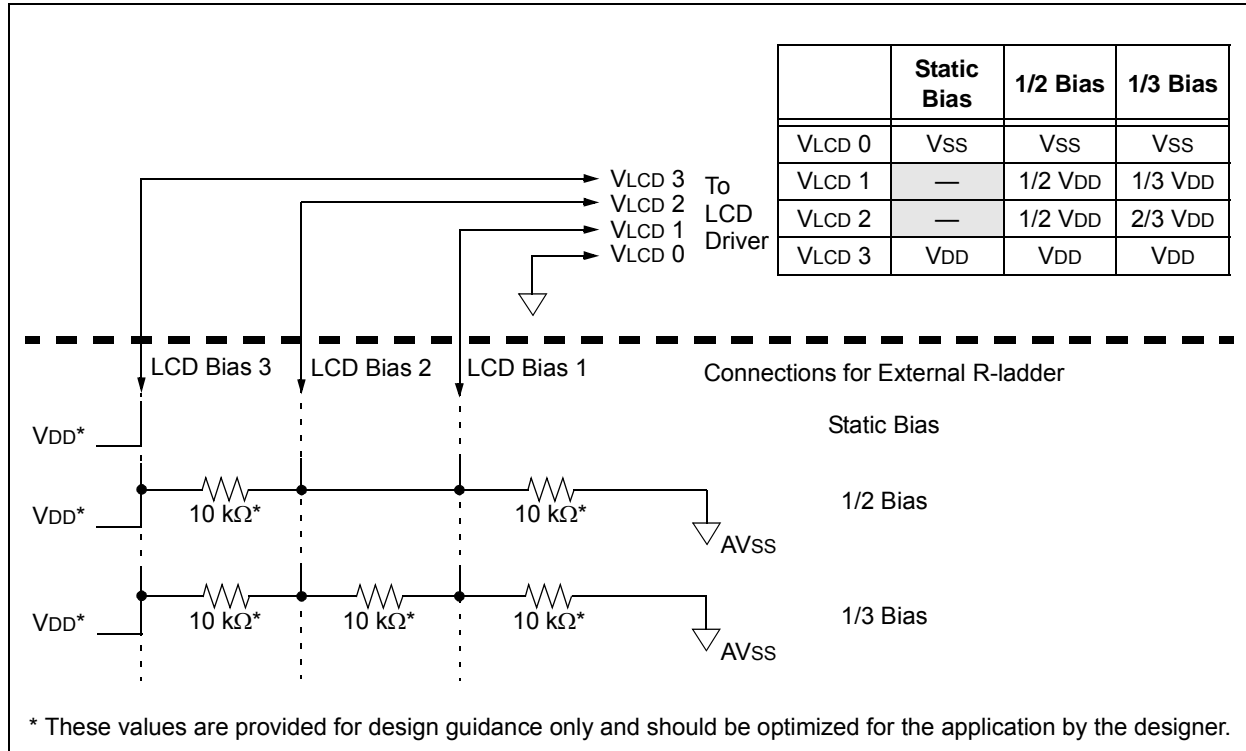
### External Resistor Ladder

One of the simplest ways to generate the bias voltages is to use a resistor ladder on the board. The LCD pixels can be considered as a capacitor, so depending on the

size of the LCD glass, capacitance can vary. The resistor ladder bias generation provides the user the flexibility to choose the resistor, based on glass size (see Figure 8).

There is an RC charge time that must be considered when the resistor and capacitor (pixel) are too high.

**FIGURE 8: RESISTOR LADDER BIASING**



The bias signals, VLCD0, VLCD1, VLCD2 and VLCD3, are connected to LCDBIAS0, LCDBIAS1, LCDBIAS2 and LCDBIAS3, respectively. For the 1/2 bias, the mid-

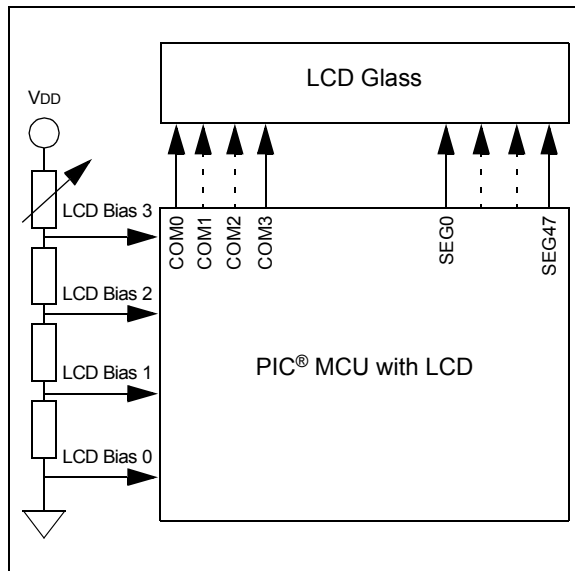
point is shorted and connected to both LCDBIAS2 and LCDBIAS1. The resistor values are chosen based on the size of the glass and the power requirements.

All the PIC18, PIC16 and PIC24 LCD microcontrollers support the external resistor ladder biasing.

## CONTRAST CONTROL USING EXTERNAL RESISTOR LADDER

The external resistor ladder contrast control can be achieved by adding a potentiometer on the resistor ladder network. By varying the potentiometer, the amplitude of the LCD wave can be varied and the contrast control can be achieved. In Figure 9, by changing the potentiometer, 'R', the contrast can be varied. Since the resistor is external, the potentiometer will have to be varied manually so that the software contrast control can be achieved.

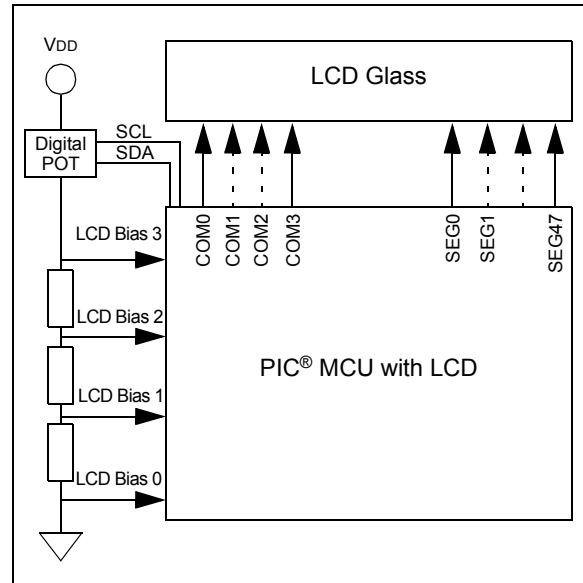
**FIGURE 9: CONTRAST CONTROL IN RESISTOR LADDER BIASING**



Most of the newer devices from Microchip support the internal biasing, as well as software contrast control. When the software contrast control is not implemented in the device, and if the applications where software contrast control is an absolute necessity, the software contrast can be achieved by using a digital pot.

With applications that require the contrast to be varied based on temperature or ambient light, a digital pot (such as MCP40D17) can be used. The pot can be adjusted by serial communication using the PIC MCU to adjust the contrast.

**FIGURE 10: SOFTWARE CONTRAST CONTROL IN RESISTOR LADDER BIASING**

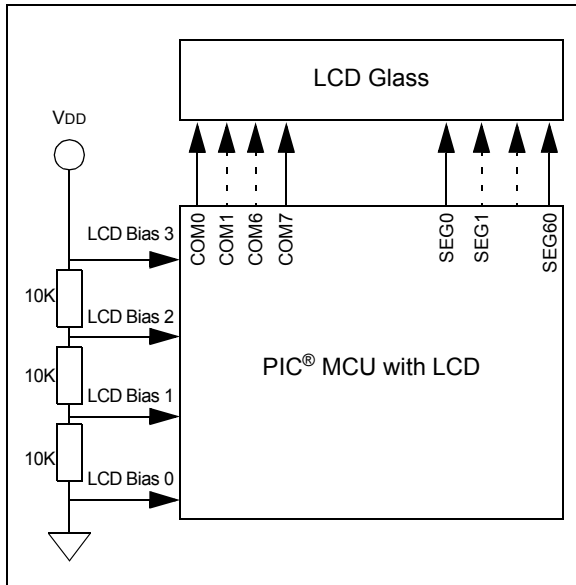


## POWER OPTIMIZATION USING EXTERNAL RESISTOR LADDER

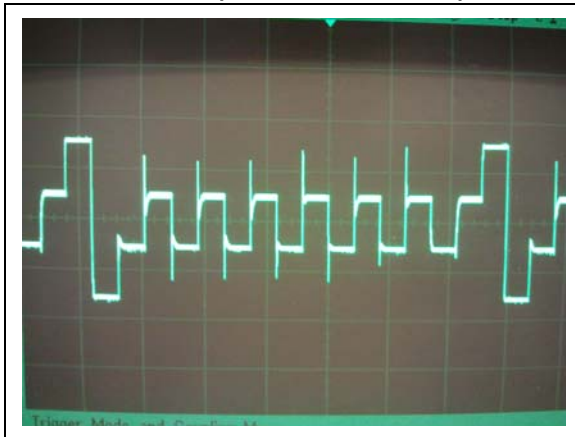
In the resistor ladder biasing, there is always a current loss through the resistor ladder. If the design is power constrained, there should be minimal loss through the resistor ladder. One way to avoid this is to increase the resistor ladder value. This is not always the best option, since at some point, the contrast will be effected. This is because of the RC change time for each pixel, since each pixel is a capacitor. It is important that the resistor ladder is at an optimum value without affecting contrast, but the current loss is minimal.

Figure 12 shows a COM0 waveform for an 8-COMMON LCD with 10K resistor ladder. This will provide a good contrast for the LCD. In battery-operated devices, where the total power is critical at 3V, the three 10K resistor ladders cause a constant drop of 100  $\mu$ A. To reduce the current, the resistor ladder value can be increased. At some point, when the resistor ladder value is increased, the contrast will become affected and the waveform shape will be altered. Therefore, an optimum resistor value should be chosen, based on the contrast and size of the pixels on the glass. Refer to Technical Brief TB1098 "Low-Power Techniques for LCD Applications" for more details on the resistor ladder selection.

**FIGURE 11: EIGHT-COMMON LCD WITH EXTERNAL RESISTOR LADDER**

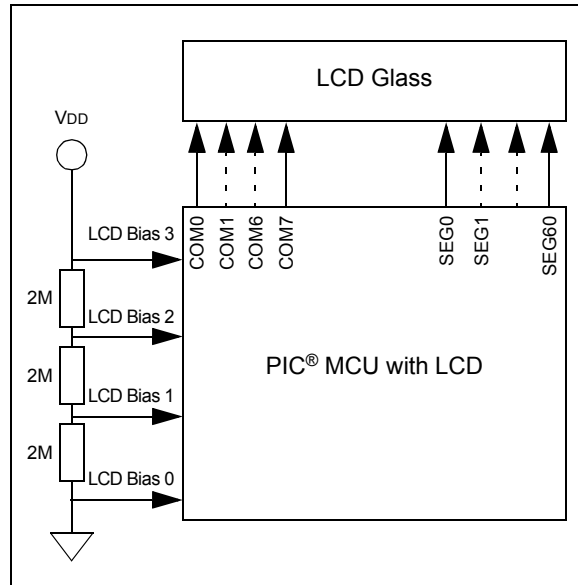


**FIGURE 12: EIGHT-COMMON LCD WAVEFORM WITH 10K RESISTOR LADDER (PIC24FJ128GA310)**



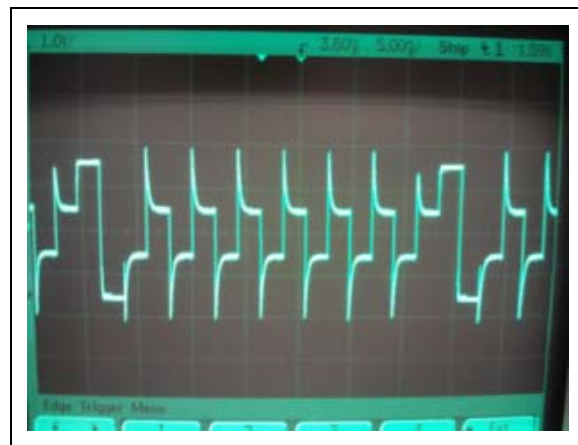
In [Figure 13](#), the resistor ladder has been increased to 2M. So the total current loss at 3V will be 0.5  $\mu$ A. This is good for battery-powered application; however, with such a high resistor value, the LCD waveform will get altered.

**FIGURE 13: EIGHT-COMMON LCD WITH EXTERNAL RESISTOR LADDER**



[Figure 14](#) shows the COM0 waveform of an 8-COMMON LCD signal. As shown, the waveform shape is altered and the contrast is also affected. It is recommended not to use a high resistor ladder where the LCD wave shape is affected, unless additional biasing is provided to take care of the waveform being altered.

**FIGURE 14: SCOPE CAPTURE OF A COM0 SIGNAL WITH 2 mOhm EXTERNAL RESISTOR BIAS**



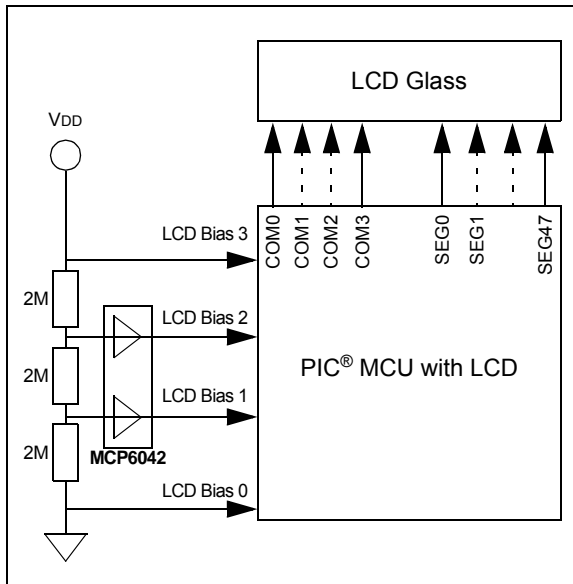
Another way to achieve this is by using additional drivers to provide sufficient current, as explained in the [“Low-Current Drivers”](#) section.



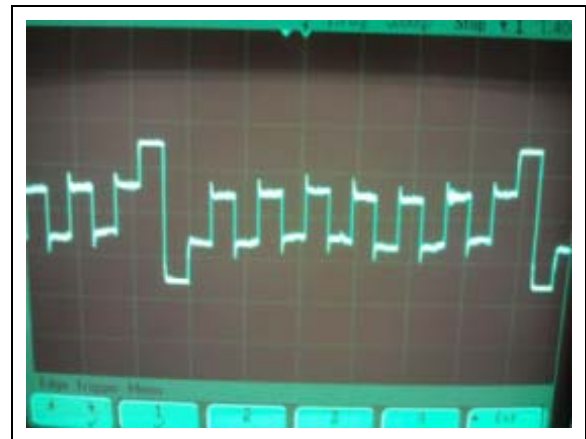
## Low-Current Drivers

If the size of the glass and pixel are big, and the resistor ladder is too high (in mOhm, as explained in the **“Contrast Control Using External Resistor Ladder”** section), it will alter the LCD waveform. By using the MCP6042 (600 nA, Rail-to-Rail Input/Output Op Amps) between the LCD Bias 2 and LCD Bias 1, the resistor ladder value can be maximized without losing any contrast. The low quiescent current (600 nA) of the MCP6042 can be utilized in low-power, battery-operated devices. Figure 16 shows the COM0 signal with a 2 mOhm resistor ladder and a MCP6042 device. By implementing this method, the LCD waveform will not be altered and the contrast will not be affected. Also, the current consumption can be optimized, regardless of the size of the LCD. Figure 16 shows the scope capture of an 8-COMMON LCD waveform using the MCP6042 buffer.

**FIGURE 15: LCD WITH EXTERNAL BIASING AND BUFFER**



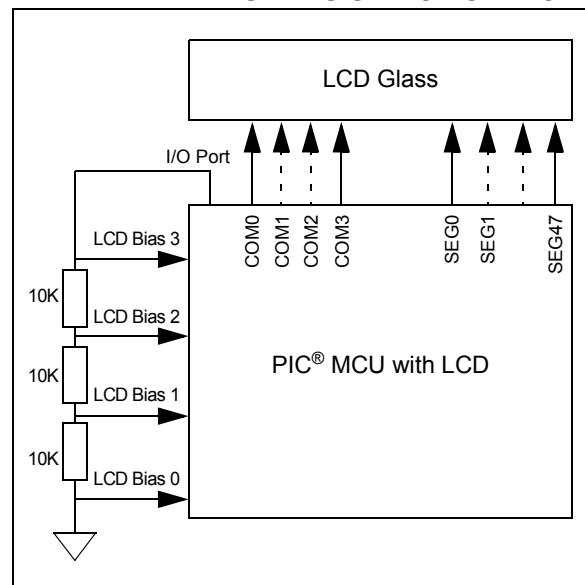
**FIGURE 16: SCOPE CAPTURE OF A COM0 SIGNAL WITH 2 mOhm EXTERNAL RESISTOR BIAS WITH BUFFER**



## Switch Off the Bias When Not in Use

Another way to decrease the power consumption is to switch off the power to the resistor ladder when the LCD is not in use, or when there is no display. Providing this option of switching the resistor ladder run time will increase the battery life significantly. One method is to use the PIC MCU output port to drive the LCD bias resistor ladder (Figure 17). Using this method, the application can switch off the bias voltage any time the LCD is not used. Also, the LCD module can be switched off, clearing LCDCON.

**FIGURE 17: LCD POWER BY AN I/O PORT TO SWITCH OFF LCD**



## Power Saving Using Clock and Sleep

Power saving can be achieved by changing the clock speed and also by putting the device to Sleep. Each of the methods has its own advantages and disadvantages.

## Sleep Mode Operation

Putting the device in Sleep with LCD will save power, because the PIC MCU is at the lowest power mode with the LCD enabled. Some of the devices have a low-voltage Sleep, during which the core is powered at a lower voltage than regular Sleep. The LCD can operate in low-voltage Sleep with really low Sleep current.

For the LCD to function, it requires clocking. There are different options for the user by which the LCD clock is chosen. The LCD can be run from:

- Main Device clock,  $F_{osc}/4$  or  $F_{osc}/2$  (with additional divider)
- Secondary Oscillator Clock
- LPRC or LF-INTOSC Clock

Each of these clocks can be further divided down to a nominal frequency, where the LCD can operate. There are additional dividers where the clock can be further divided through software to get the optimal frequency for a particular LCD.

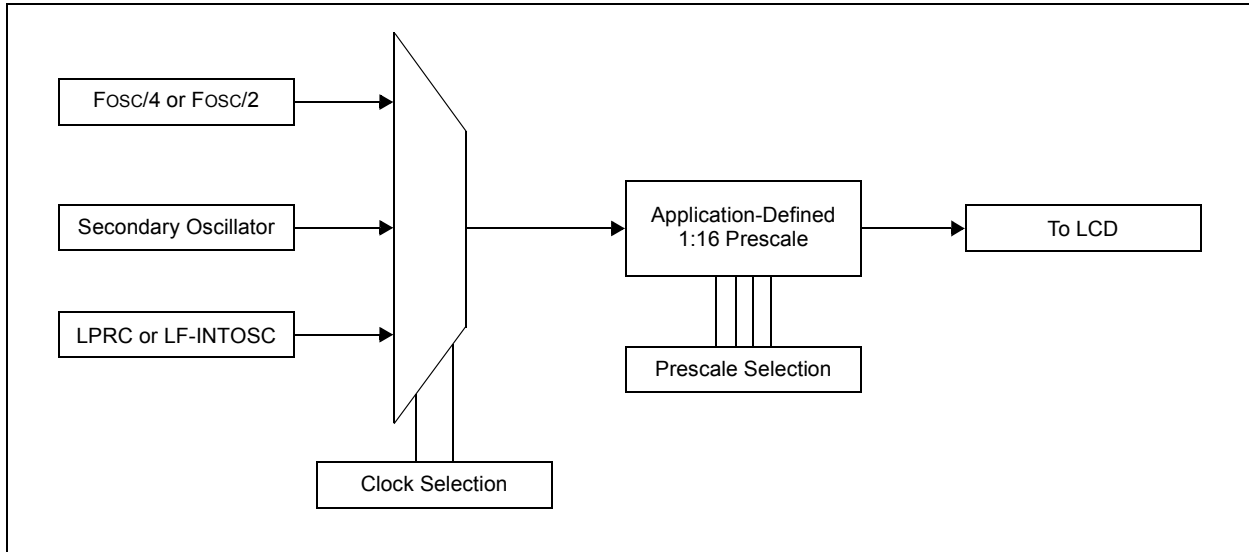
When in Sleep, the microcontroller main clock is switched off to save power. However, if the Secondary or the LPRC Clock is in use, it will keep running if used by the LCD (or other peripherals). The LCD is designed so that it can operate or shut off during Sleep. The user has a software option to keep the LCD running during Sleep.

Putting the LCD in Sleep will save power; all of the COMMON and SEGMENT signals will still be active and keep the LCD on. Since the main clock is off during Sleep, the display content cannot be changed during Sleep. Therefore, during Sleep, the LCD will be on and will display the content before the `SLEEP` command is executed.

## Clock Division

The three clocks for the LCD have their own inbuilt divider. This divided clock goes to the LCD module, where it can be further divided by a user-defined prescale option.

**FIGURE 18: LCD CLOCK SELECTION AND PRESCALE**



The LCD receives its clock after the prescale option. The user can define the frequency using the prescale. The higher the frequency, the higher the current consumed by the LCD module. Flicker fusion rate is a term that can be used to define the frame rate.

Flicker fusion rate is the number of frames, per second, required to produce a continuous motion. The flicker fusion rate is dependent on the light where it is viewed. The brighter the room, the higher flicker fusion rate is required to eliminate the flicker. In a movie theater, the room is darker and the flicker fusion rate is lower than a flicker fusion rate of a TV (60 Hz), which is usually viewed in a lighted room. For the LCD, a flicker fusion rate (frame frequency) of 30-50 Hz will produce a very good display without any flicker.

Operating the LCD at a lower frequency has the advantage of low-power operation, but if the frequency is too low because of the above explained flicker fusion rate, the display will start flickering. If too high a frequency is used, it will consume more power. So, an optimum frequency should be selected to optimize the contrast and power, depending on the available light in the room.

## Internal Resistor Ladder

Some of the newer PIC16/PIC18/PIC24 devices have an internal resistor ladder, implemented internally in the device. This unique feature of the internal resistor ladder helps the resistor ladder to be optimized for a given glass.

The advantage of the internal resistor ladder is:

1. Less components on the board, which reduces design cost.
2. Provides the user the ability to change the resistor ladder during run time with built-in software contrast control.
3. Provides full control to switch the resistor ladder off if the LCD is not used. This gives the user the flexibility to save power when the LCD is not used.
4. Since the bias voltages are generated internally, the external resistor ladder bias pins can be used for general purpose ports.

In the design, there are three resistor ladders. These resistor ladders can be changed automatically during an LCD frame in run time. The resistor ladders are classified into high power, medium and low power. Their typical values are provided in [Table 1](#). For a glass with larger sized pixels, it will need more current to charge, so the High-Power mode resistor ladder needs to be used. If the application needs to run an extremely small LCD with small pixels, the low-power ladder can be used. This gives the user the flexibility to switch between different ladders, depending on the application.

# AN1428

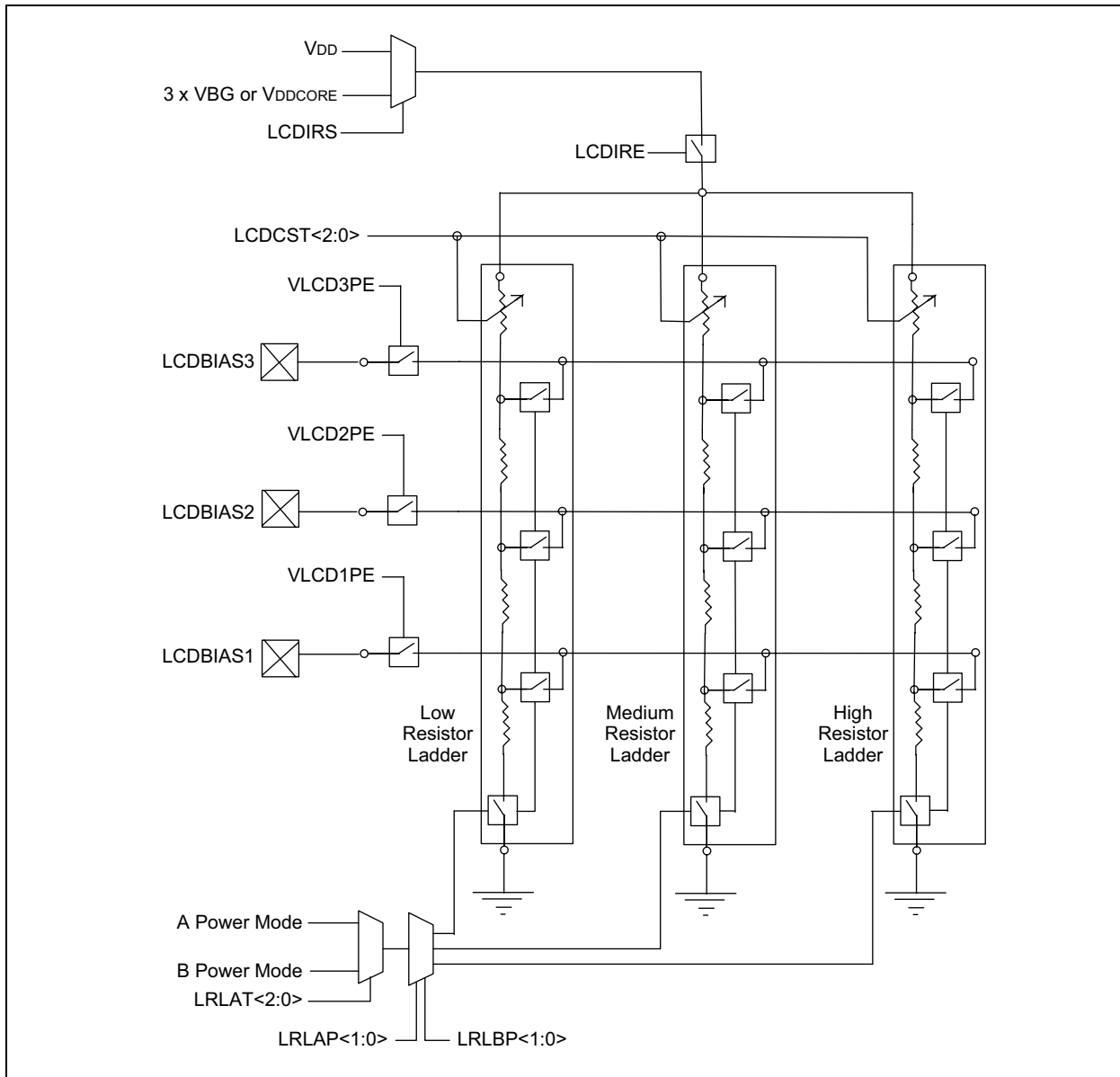
**TABLE 1: TYPICAL RESISTOR LADDER VALUES AND CURRENT AT 3V**

Power Mode	Nominal Resistance of Entire Ladder	I <sub>DD</sub>
Low	3 MΩ	1 μA
Medium	300 kΩ	10 μA
High	30 kΩ	100 μA

## POWER OPTIMIZATION WITH INTERNAL RESISTOR LADDER

In battery-operated devices, current consumption is extremely critical. Running the resistor ladder can consume current. The current consumption is highest during switching. By applying the high power during switching, and low power during the period where there is no switching, the current can be further optimized without losing contrast. The internal resistor ladder allows the user to keep switching between the ladders, saving power without losing contrast.

**FIGURE 19: INTERNAL RESISTOR LADDER BIASING**



## POWER MODE SELECTION

There are two power modes, designated as “Mode A” and “Mode B”. Mode A is the High-Power mode and Mode B is the Low-Power mode. Mode A power is active for a programmable time, beginning when the LCD SEGMENT waveform is transitioning.

There are 2 bits for each of these modes that decide which ladder is connected in that particular mode.

Mode A has 3 modes and a Disconnect mode:

- 11 = Internal ladder is powered in High-Power mode
- 10 = Internal ladder is powered in Medium Power mode
- 01 = Internal ladder is powered in Low-Power mode
- 00 = Internal ladder is powered down and unconnected

Mode B has 3 modes and a Disconnect mode:

- 11 = Internal ladder is powered in High-Power mode
- 10 = Internal ladder is powered in Medium Power mode
- 01 = Internal ladder is powered in Low-Power mode
- 00 = Internal ladder is powered down and unconnected

The user can use these bits to configure which ladder needs to be connected during Mode A, and which one needs to be connected in Mode B. Putting the low-power ladder in both modes provides the best operation for power, but may lose contrast because of the high-power resistor ladder. Mode A is used during the switching phase and should be able to source more current. It is better to opt for a higher current ladder for this mode and a lower current ladder for Mode B.

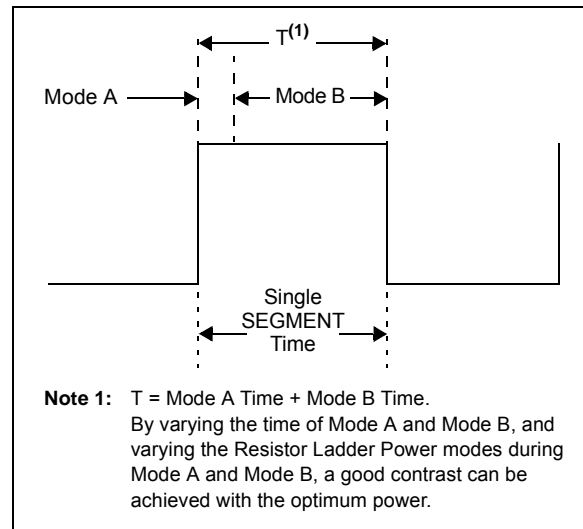
## POWER MODE DURATION

Now, once the Mode A and Mode B resistor ladder values are chosen, the user has the flexibility to decide how long Mode A will operate, and how long Mode B will operate, during a SEGMENT time period.

There are three bits that can be used to select how long these resistor ladders can be active. Software bits select how long Mode A is active. Mode B Power mode is active for the remaining time before the SEGMENTS or COMMONs change again. The total time for Mode A and Mode B is, ‘T’. The three software bits that decide how long each mode can be on during time, ‘T’:

- 000 = Internal ladder is always in B Power mode
- 001 = Internal ladder is in A Power mode for 1 clock and B Power mode for 15 clocks
- 010 = Internal ladder is in A Power mode for 2 clocks and B Power mode for 14 clocks
- 011 = Internal ladder is in A Power mode for 3 clocks and B Power mode for 13 clocks
- 100 = Internal ladder is in A Power mode for 4 clocks and B Power mode for 12 clocks
- 101 = Internal ladder is in A Power mode for 5 clocks and B Power mode for 11 clocks
- 110 = Internal ladder is in A Power mode for 6 clocks and B Power mode for 10 clocks
- 111 = Internal ladder is in A Power mode for 7 clocks and B Power mode for 9 clocks

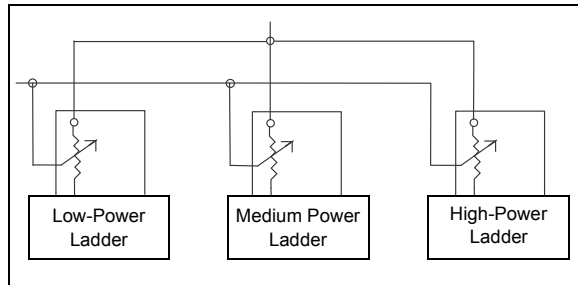
**FIGURE 20: INTERNAL RESISTOR LADDER BIAS TIMING**



## Contrast Control Using Internal Resistor Bias

Each of the three resistor ladders has its own internal potentiometer by which the resistor values can be varied. The resistor ladder can be varied by the contrast control software bits (LCDCST<2:0>). There are seven modes to select where it can go from maximum contrast to minimum contrast.

**FIGURE 21: INTERNAL RESISTOR LADDER CONTRAST CONTROL REGISTER**



### LCDCST<2:0>: LCD Contrast Control bits

Selects the resistance of the LCD contrast control resistor ladder:

- 111 = Resistor ladder is at maximum resistance (minimum contrast)
- 110 = Resistor ladder is at 6/7th of maximum resistance
- 101 = Resistor ladder is at 5/7th of maximum resistance
- 100 = Resistor ladder is at 4/7th of maximum resistance
- 011 = Resistor ladder is at 3/7th of maximum resistance
- 010 = Resistor ladder is at 2/7th of maximum resistance
- 001 = Resistor ladder is at 1/7th of maximum resistance
- 000 = Minimum resistance (maximum contrast); resistor ladder is shorted

Depending upon which ladder is being used, the corresponding potentiometer for that ladder will provide the contrast control for that duration. Run-time contrast control is something that is useful in applications as contrast can vary, based on the ambient light amplitude of the LCD waveform. By giving the value, '000', the contrast control resistor can be taken out of the resistor ladder.

## Charge Pump Biasing

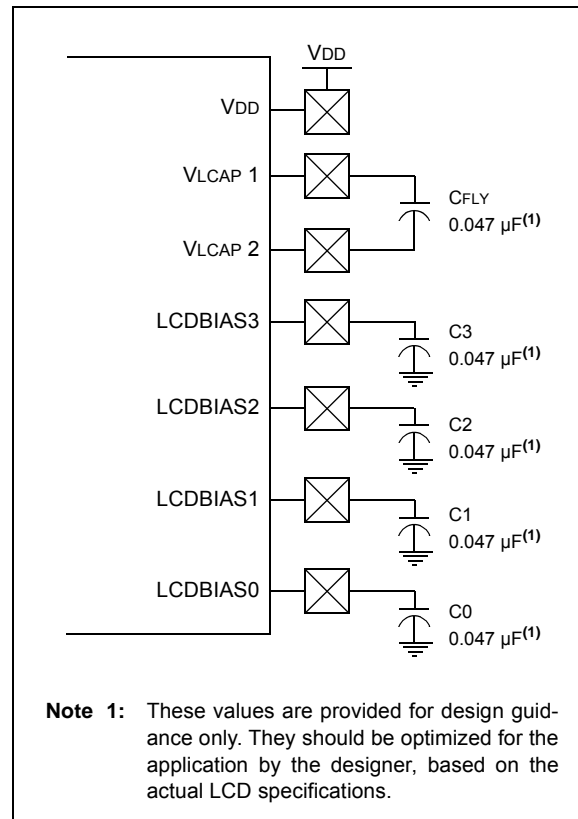
Some of the devices, 3V devices which are designed for battery operated applications, have an inbuilt charge pump to generate the bias voltages.

The advantage of the charge pump is:

- The ability for the LCD to run down to the minimum voltage of the device (2V, typical), as most of the 3V LCD will stop working with good contrast around 2.7V, the charge pump will keep the LCD signal to the required 3V, even if the VDD is down to 2V.
- Software contrast control is possible using the charge pump.
- With the charge pump, the LCD can get more from the given battery life.

The charge pump connection is shown in [Figure 22](#).

**FIGURE 22: CHARGE PUMP BIASING**



**Note 1:** These values are provided for design guidance only. They should be optimized for the application by the designer, based on the actual LCD specifications.

## DESIGN CONSIDERATIONS FOR THE LCD CHARGE PUMP

When designing applications that use the LCD regulator, with the charge pump enabled, users must always consider both the dynamic current and RMS (static) current requirements of the display, and what the charge pump can deliver. Both dynamic and static current can be determined by [Equation 1](#):

### EQUATION 1: DYNAMIC AND STATIC CURRENT REQUIREMENTS

$$I = C \times \frac{dV}{dT}$$

For dynamic current,  $C$  is the value of the capacitors attached to LCDBIAS3 and LCDBIAS2. The variable,  $dV$ , is the voltage drop allowed on C2 and C3 during a voltage switch on the LCD display, and  $dT$  is the duration of the transient current after a clock pulse occurs. For practical design purposes, these will be assumed to be 0.047  $\mu\text{F}$  for  $C$ , 0.1V for  $dV$  and 1  $\mu\text{S}$  for  $dT$ . This yields a dynamic current of 4.7 mA for 1  $\mu\text{S}$ .

Users should compare the calculated current capacity against the requirements of the LCD. While  $dV$  and  $dT$  are relatively fixed by device design, the values of CFLY and the capacitors on the LCDBIAS pins can be changed to increase or decrease the current. As always, any changes should be evaluated in the actual circuit for their impact on the application.

## OPERATING MODES WITH CHARGE PUMP

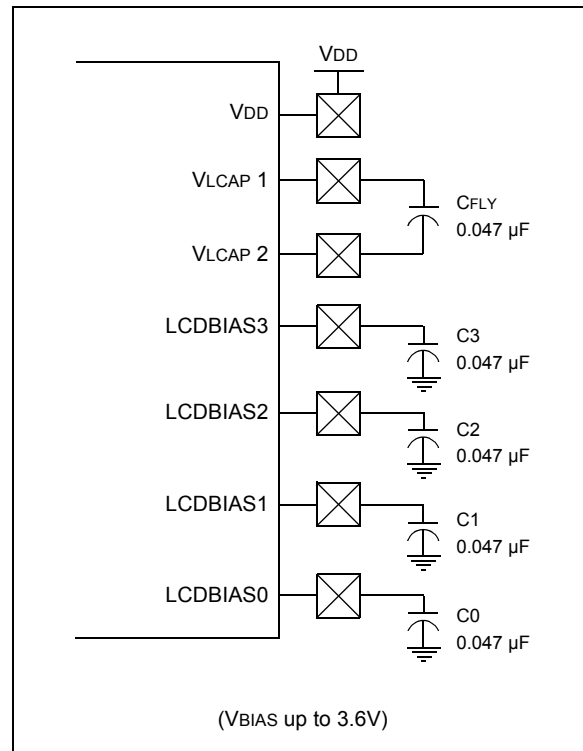
There are four modes of operation for the LCD:

- M0: Regulator with Boost
- M1: Regulator without Boost
- M2: Resistor Ladder with Software Contrast
- M3: Resistor Ladder with Hardware Contrast

### M0: Regulator with Boost

In M0 operation, the LCD charge pump feature is enabled. This allows the regulator to generate voltages up to +3.6V to the LCD (as measured at LCDBIAS3). M0 uses a flyback capacitor, connected between VLCAP 1 and VLCAP 2, as well as filter capacitors on LCDBIAS0 through LCDBIAS3, to obtain the required voltage boost ([Figure 23](#)).

**FIGURE 23: CHARGE PUMP BIASING, M0 MODE**



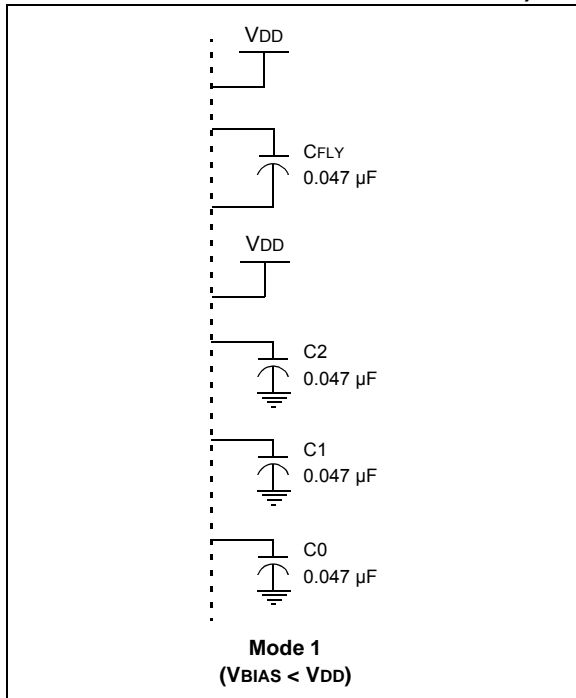
The output voltage ( $V_{BIAS}$ ) is the difference of potential between LCDBIAS3 and LCDBIAS0. It is set by the BIAS<2:0> bits, which adjust the offset between LCDBIAS0 and Vss. The Flyback Capacitor (CFLY) acts as a charge storage element for large LCD loads. This mode is useful in those cases where the voltage requirements of the LCD are higher than the microcontroller's VDD. It also permits software control of the display's contrast with the adjustment of the bias voltage, by changing the value of the BIASx bits.

### M1 (Regulator without Boost)

M1 operation is similar to M0, but does not use the LCD charge pump. It can provide  $V_{BIAS}$  up to the voltage level, supplied directly to LCDBIAS3. It can be used in cases where VDD for the application is expected to never drop below a level that can provide adequate contrast for the LCD. The connection of external components is very similar to M0, except that LCDBIAS3 must be tied directly to VDD.

The BIAS<2:0> bits can still be used to adjust contrast in software by changing  $V_{BIAS}$ . As with M0, changing these bits changes the offset between LCDBIAS0 and Vss. In M1, this is reflected in the change between LCDBIAS0 and the voltage tied to LCDBIAS3. Thus, if VDD should change,  $V_{BIAS}$  will also change; wherein M0, the level of  $V_{BIAS}$  is constant ([Figure 24](#)).

**FIGURE 24: CHARGE PUMP BIAS, M1 (RESISTOR LADDER WITH SOFTWARE CONTRAST)**



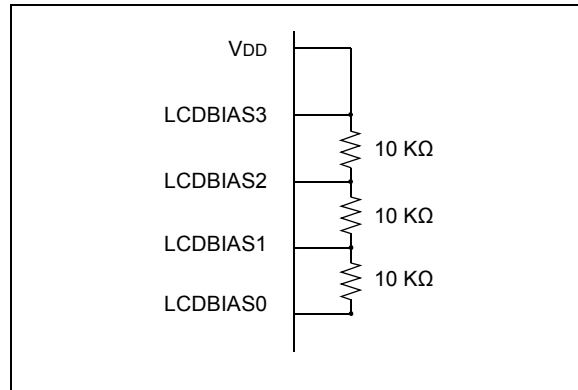
### M2 (Resistor Ladder with Software Contrast)

M2 operation also uses the LCD regulator but disables the charge pump. The regulator's internal voltage reference remains active as a way to regulate contrast. It is used in cases where the current requirements of the LCD exceed the capacity of the regulator's charge pump.

In this configuration, the LCD bias voltage levels are created by an external resistor voltage divider, connected across LCDBIAS0 through LCDBIAS3, with the top of the divider tied to VDD (Figure 24). The potential at the bottom of the ladder is determined by the LCD regulator's voltage reference, tied internally to LCDBIAS0. The bias type is determined by the voltages on the LCDBIAS pins, which are controlled by the configuration of the resistor ladder.

Like M1, the LCDBIAS bits can be used to control contrast, limited by the level of VDD supplied to the device. Also, since there is no capacitor required across VLCAP 1 and VLCAP 2, these pins are available as digital I/O ports, RG2 and RG3.

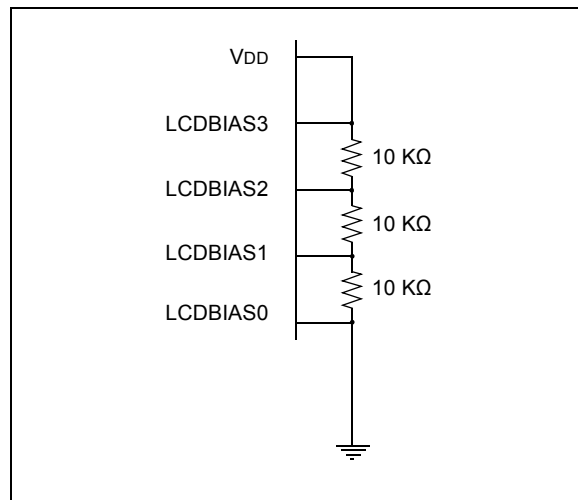
**FIGURE 25: CHARGE PUMP BIASING, M2 MODE**



### M3 (Hardware Contrast)

In M3, the LCD regulator is completely disabled. Like M2, LCD bias levels are tied to VDD and are generated using an external divider. The difference is that the internal voltage reference is also disabled and the bottom of the ladder is tied to ground (VSS); see Figure 26. The value of the resistors and the difference between VSS and VDD determine the contrast range; no software adjustment is possible. This configuration is also used where the LCD's current requirements exceed the capacity of the charge pump, and software contrast control is not needed.

**FIGURE 26: CHARGE PUMP BIASING, M3 MODE**





## Battery Power and Contrast

Most of the glass designed for 3V operation will work well at about 2.8V-2.7V, with reasonable contrast. Below 2.7V, the LCD glass will not have enough contrast, even though the LCD waveforms are coming out

on the LCD SEGMENT and COMMON pins. To utilize most of the battery life, the LCD biasing can be done with the charge pump.

As explained in “[M0: Regulator with Boost](#)”, the LCD can operate even when the V<sub>DD</sub> is below the LCD specification or minimum voltage.

**FIGURE 27: *ENERGIZER*® ULTIMATE LITHIUM AAA (L92) BATTERY DISCHARGE CURVE WITH RUN-TIME BIAS SWITCHING**

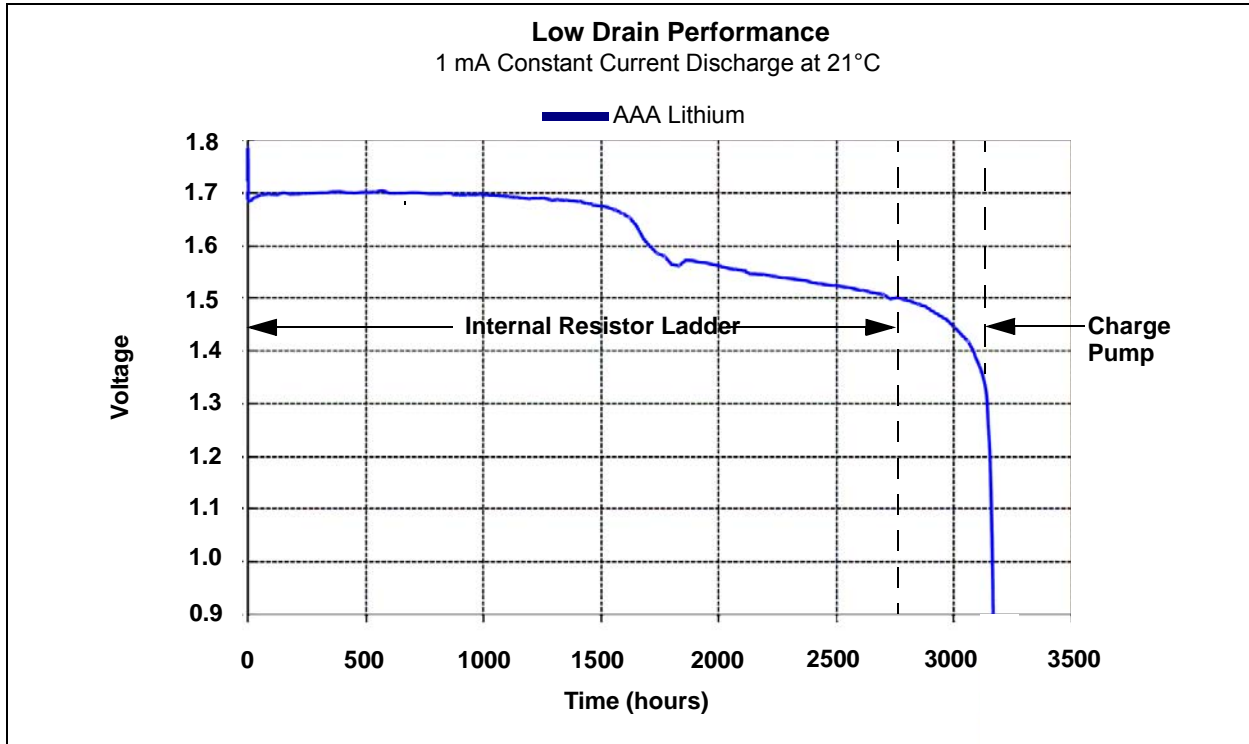


Figure 27 shows the drain performance of an Energizer® Ultimate Lithium AAA (L92). Two fresh batteries in series will maintain an output of greater than 3.0V (2 x 1.5V), out to 15%, of their remaining capacity. The high-efficiency internal resistor ladder bias should be used until this point is reached. Once the battery voltage begins to fall, switching to the charge pump maximizes the application life and utilizes all of the battery’s capacity.

The PIC24FJ128GA310 is one microcontroller family that has both the internal resistor ladder, and the charge pump, implemented in its LCD module.

# AN1428

---

The A/D of the PIC24FJ128GA310 has an internal band gap voltage reference by which the VDD voltage can be monitored. The application can switch between internal and charge pump bias based on the VDD volt-

age. The demo code of the LCD Explorer Board (available on [www.microchip.com](http://www.microchip.com)) demonstrates the BIAS switching between the charge pump and the internal resistor ladder that is monitoring the VDD.

## EXAMPLE 1: CODE EXAMPLE TO SWITCH BETWEEN RESISTOR LADDER AND CHARGE PUMP

```
if(VDD_RES2<2700) // Monitor if Vdd is below 2.7V
{
    LCDBiasStatus=CHARGE PUMP; //Charge Pump enabled
    TRISBbits.TRISB6=1; //Bias3
    TRISEbits.TRISE5=1; //Bias2
    TRISEbits.TRISE6=1; //Bias1
    TRISEbits.TRISE7=1; //Bias0

    TRISGbits.TRISG7=1; //VLCAP1
    TRISGbits.TRISG8=1; //VLCAP2

    LCDREG=0x802f;
    LCDREF=0x0700; //external
    LCDPS=0x0002;
    LCDCON=0x8001F; //8 common
    CStatus=1;

else //internal resistor ladder
{
    LCDBiasStatus=RESISTOR; //Internal resistor Ladder
    LCDREG=0x0004;
    LCDREF=0x80FF; //internal resistor ladder
    LCDPS=0x0002;
    LCDREFbits.LCDCST=0;
    LCDCON=0x800f; // 8 common
    RStatus=1;

}
```

## Image Quality and Contrast

Other than the amplitude control of the waveform, there are other factors that can affect the contrast. These factors need to be considered when the LCD application is designed. One of the features is called viewing angle. This is usually recommended by the LCD manufacturer, so when a custom LCD is ordered, the user can define to the vendor what kind of application it goes into. Whether it is a product which is high on the wall, such as a clock (viewed from the bottom), or something that is designed to be on a desk, which is viewed.

If the LCD is designed for a bottom view (or 6:00 view), it will not provide very good contrast if viewed at the top (or 12:00). However, with adjusting the contrast, some optimization can be achieved.

In applications, there are multiple factors that need to be considered to get the best, or the optimum contrast, and good image:

- Ambient light (or backlight if available for the LCD)
- Amplitude of the LCD waveform compared to the LCD specification
- Operating the LCD at the right temperature for which the LCD is designed
- Using the LCD with the correct viewing angle, designed by the manufacturer
- Operating the LCD with the right frame frequency (flicker fusion rate)

## LCD PIC® Microcontrollers

Depending on the biasing, SEGMENTS and multiplexing, there are quite a few LCD PIC microcontrollers available, and more devices with advanced low-power features will be coming in the future. Depending on the application, power requirement and LCD pins, there are quite a few different features the LCD PIC MCU controllers can offer.

The available products are on the following web site:  
<http://www.microchip.com/lcd>

Devices can support –  
Multiplexing and Biasing:

- Static Drive
- 1/2 Multiplexing
- 1/3 Multiplexing
- 1/4 Multiplexing
- 1/5 Multiplexing
- 1/6 Multiplexing
- 1/7 Multiplexing
- 1/8 Multiplexing

Bias Level Support:

- Static
- 1/2 Bias
- 1/3 Bias

Bias Voltage Generation:

- External Resistor Ladder
- Internal Resistor Ladder with Software Contrast Control
- Charge Pump Bias with Software Contrast Control

LCD SEGMENTS:

- Static with a Maximum of 64 SEGMENTS can Drive 64 Pixels
- 1/8 Multiplex with 60 SEGMENTS can Drive 480 Pixels

Low-Power Operation Features:

- LCD can Operate in Sleep
- LCD can Operate in Low-Voltage/Retention Sleep
- Clock Divider for LCD to Optimize the Power
- Internal Resistor Ladder with Dynamic Power Modes
- Switching Between the Internal Resistor Ladder and Charge Pump Bias.

# AN1428

---

## REFERENCES

AN658, “LCD Fundamentals Using PIC16C92X Microcontrollers” (DS00658)

LCD PIC<sup>®</sup> MCU Tips ‘n Tricks (DS41261)

TB084, “Contrast Control Circuits for the PIC16F91X” (DS91084)

2012 – “Energizer<sup>®</sup>”.

---

**Note the following details of the code protection feature on Microchip devices:**

- Microchip products meet the specification contained in their particular Microchip Data Sheet.
- Microchip believes that its family of products is one of the most secure families of its kind on the market today, when used in the intended manner and under normal conditions.
- There are dishonest and possibly illegal methods used to breach the code protection feature. All of these methods, to our knowledge, require using the Microchip products in a manner outside the operating specifications contained in Microchip's Data Sheets. Most likely, the person doing so is engaged in theft of intellectual property.
- Microchip is willing to work with the customer who is concerned about the integrity of their code.
- Neither Microchip nor any other semiconductor manufacturer can guarantee the security of their code. Code protection does not mean that we are guaranteeing the product as “unbreakable.”

Code protection is constantly evolving. We at Microchip are committed to continuously improving the code protection features of our products. Attempts to break Microchip's code protection feature may be a violation of the Digital Millennium Copyright Act. If such acts allow unauthorized access to your software or other copyrighted work, you may have a right to sue for relief under that Act.

---

Information contained in this publication regarding device applications and the like is provided only for your convenience and may be superseded by updates. It is your responsibility to ensure that your application meets with your specifications. MICROCHIP MAKES NO REPRESENTATIONS OR WARRANTIES OF ANY KIND WHETHER EXPRESS OR IMPLIED, WRITTEN OR ORAL, STATUTORY OR OTHERWISE, RELATED TO THE INFORMATION, INCLUDING BUT NOT LIMITED TO ITS CONDITION, QUALITY, PERFORMANCE, MERCHANTABILITY OR FITNESS FOR PURPOSE. Microchip disclaims all liability arising from this information and its use. Use of Microchip devices in life support and/or safety applications is entirely at the buyer's risk, and the buyer agrees to defend, indemnify and hold harmless Microchip from any and all damages, claims, suits, or expenses resulting from such use. No licenses are conveyed, implicitly or otherwise, under any Microchip intellectual property rights.

**Trademarks**

The Microchip name and logo, the Microchip logo, dsPIC, KEELOQ, KEELOQ logo, MPLAB, PIC, PICmicro, PICSTART, PIC<sup>32</sup> logo, rPIC and UNI/O are registered trademarks of Microchip Technology Incorporated in the U.S.A. and other countries.

FilterLab, Hampshire, HI-TECH C, Linear Active Thermistor, MXDEV, MXLAB, SEEVAL and The Embedded Control Solutions Company are registered trademarks of Microchip Technology Incorporated in the U.S.A.

Analog-for-the-Digital Age, Application Maestro, chipKIT, chipKIT logo, CodeGuard, dsPICDEM, dsPICDEM.net, dsPICworks, dsSPEAK, ECAN, ECONOMONITOR, FanSense, HI-TIDE, In-Circuit Serial Programming, ICSP, Mindi, MiWi, MPASM, MPLAB Certified logo, MPLIB, MPLINK, mTouch, Omniscient Code Generation, PICC, PICC-18, PICDEM, PICDEM.net, PICKit, PICtail, REAL ICE, rLAB, Select Mode, Total Endurance, TSHARC, UniWinDriver, WiperLock and ZENA are trademarks of Microchip Technology Incorporated in the U.S.A. and other countries.

SQTP is a service mark of Microchip Technology Incorporated in the U.S.A.

All other trademarks mentioned herein are property of their respective companies.

© 2012, Microchip Technology Incorporated, Printed in the U.S.A., All Rights Reserved.

 Printed on recycled paper.

ISBN: 978-1-62076-254-7

**QUALITY MANAGEMENT SYSTEM**  
**CERTIFIED BY DNV**  
**== ISO/TS 16949 ==**

*Microchip received ISO/TS-16949:2009 certification for its worldwide headquarters, design and wafer fabrication facilities in Chandler and Tempe, Arizona; Gresham, Oregon and design centers in California and India. The Company's quality system processes and procedures are for its PIC<sup>®</sup> MCUs and dsPIC<sup>®</sup> DSCs, KEELOQ<sup>®</sup> code hopping devices, Serial EEPROMs, microperipherals, nonvolatile memory and analog products. In addition, Microchip's quality system for the design and manufacture of development systems is ISO 9001:2000 certified.*



# MICROCHIP

## Worldwide Sales and Service

### AMERICAS

**Corporate Office**  
2355 West Chandler Blvd.  
Chandler, AZ 85224-6199  
Tel: 480-792-7200  
Fax: 480-792-7277  
Technical Support:  
<http://www.microchip.com/support>  
Web Address:  
[www.microchip.com](http://www.microchip.com)

**Atlanta**  
Duluth, GA  
Tel: 678-957-9614  
Fax: 678-957-1455

**Boston**  
Westborough, MA  
Tel: 774-760-0087  
Fax: 774-760-0088

**Chicago**  
Itasca, IL  
Tel: 630-285-0071  
Fax: 630-285-0075

**Cleveland**  
Independence, OH  
Tel: 216-447-0464  
Fax: 216-447-0643

**Dallas**  
Addison, TX  
Tel: 972-818-7423  
Fax: 972-818-2924

**Detroit**  
Farmington Hills, MI  
Tel: 248-538-2250  
Fax: 248-538-2260

**Indianapolis**  
Noblesville, IN  
Tel: 317-773-8323  
Fax: 317-773-5453

**Los Angeles**  
Mission Viejo, CA  
Tel: 949-462-9523  
Fax: 949-462-9608

**Santa Clara**  
Santa Clara, CA  
Tel: 408-961-6444  
Fax: 408-961-6445

**Toronto**  
Mississauga, Ontario,  
Canada  
Tel: 905-673-0699  
Fax: 905-673-6509

### ASIA/PACIFIC

**Asia Pacific Office**  
Suites 3707-14, 37th Floor  
Tower 6, The Gateway  
Harbour City, Kowloon  
Hong Kong  
Tel: 852-2401-1200  
Fax: 852-2401-3431

**Australia - Sydney**  
Tel: 61-2-9868-6733  
Fax: 61-2-9868-6755

**China - Beijing**  
Tel: 86-10-8569-7000  
Fax: 86-10-8528-2104

**China - Chengdu**  
Tel: 86-28-8665-5511  
Fax: 86-28-8665-7889

**China - Chongqing**  
Tel: 86-23-8980-9588  
Fax: 86-23-8980-9500

**China - Hangzhou**  
Tel: 86-571-2819-3187  
Fax: 86-571-2819-3189

**China - Hong Kong SAR**  
Tel: 852-2401-1200  
Fax: 852-2401-3431

**China - Nanjing**  
Tel: 86-25-8473-2460  
Fax: 86-25-8473-2470

**China - Qingdao**  
Tel: 86-532-8502-7355  
Fax: 86-532-8502-7205

**China - Shanghai**  
Tel: 86-21-5407-5533  
Fax: 86-21-5407-5066

**China - Shenyang**  
Tel: 86-24-2334-2829  
Fax: 86-24-2334-2393

**China - Shenzhen**  
Tel: 86-755-8203-2660  
Fax: 86-755-8203-1760

**China - Wuhan**  
Tel: 86-27-5980-5300  
Fax: 86-27-5980-5118

**China - Xian**  
Tel: 86-29-8833-7252  
Fax: 86-29-8833-7256

**China - Xiamen**  
Tel: 86-592-2388138  
Fax: 86-592-2388130

**China - Zhuhai**  
Tel: 86-756-3210040  
Fax: 86-756-3210049

### ASIA/PACIFIC

**India - Bangalore**  
Tel: 91-80-3090-4444  
Fax: 91-80-3090-4123

**India - New Delhi**  
Tel: 91-11-4160-8631  
Fax: 91-11-4160-8632

**India - Pune**  
Tel: 91-20-2566-1512  
Fax: 91-20-2566-1513

**Japan - Osaka**  
Tel: 81-66-152-7160  
Fax: 81-66-152-9310

**Japan - Yokohama**  
Tel: 81-45-471-6166  
Fax: 81-45-471-6122

**Korea - Daegu**  
Tel: 82-53-744-4301  
Fax: 82-53-744-4302

**Korea - Seoul**  
Tel: 82-2-554-7200  
Fax: 82-2-558-5932 or  
82-2-558-5934

**Malaysia - Kuala Lumpur**  
Tel: 60-3-6201-9857  
Fax: 60-3-6201-9859

**Malaysia - Penang**  
Tel: 60-4-227-8870  
Fax: 60-4-227-4068

**Philippines - Manila**  
Tel: 63-2-634-9065  
Fax: 63-2-634-9069

**Singapore**  
Tel: 65-6334-8870  
Fax: 65-6334-8850

**Taiwan - Hsin Chu**  
Tel: 886-3-5778-366  
Fax: 886-3-5770-955

**Taiwan - Kaohsiung**  
Tel: 886-7-536-4818  
Fax: 886-7-330-9305

**Taiwan - Taipei**  
Tel: 886-2-2500-6610  
Fax: 886-2-2508-0102

**Thailand - Bangkok**  
Tel: 66-2-694-1351  
Fax: 66-2-694-1350

### EUROPE

**Austria - Wels**  
Tel: 43-7242-2244-39  
Fax: 43-7242-2244-393

**Denmark - Copenhagen**  
Tel: 45-4450-2828  
Fax: 45-4485-2829

**France - Paris**  
Tel: 33-1-69-53-63-20  
Fax: 33-1-69-30-90-79

**Germany - Munich**  
Tel: 49-89-627-144-0  
Fax: 49-89-627-144-44

**Italy - Milan**  
Tel: 39-0331-742611  
Fax: 39-0331-466781

**Netherlands - Drunen**  
Tel: 31-416-690399  
Fax: 31-416-690340

**Spain - Madrid**  
Tel: 34-91-708-08-90  
Fax: 34-91-708-08-91

**UK - Wokingham**  
Tel: 44-118-921-5869  
Fax: 44-118-921-5820

11/29/11