

Instrumentation Electronics at a Juncture



By Bonnie C. Baker, Microchip Technology Inc.

ANALOG DESIGN NOTE ADN002

Introduction

Process control and instrumentation solutions rose out of the 1970s/1980s revolution in electronics. From that endeavor the well-known instrumentation amplifier came into existence. Structures like a three-op amp design, followed by a two-op amp version were built discretely with a few resistors and op amps. This solution was later made available on an integrated chip. It may seem that things haven't changed much since then, but not so. The digital revolution, that is just coming into its own, is now encroaching on that traditional analog territory.

Instrumentation amplifiers are good for gaining differential input signals and rejecting common mode noise, but fall short when there are multiple sensor inputs that need to be integrated into the system. For instance, a pressure sensor or load cell require an instrumentation amplifier to change their differential output signal into a single voltage. But often these systems need temperature data for calibration. This temperature data is acquired through a separate signal path.

An alternative to having two separate signal paths is to use a single-ended input/output Programmable Gain Amplifier (PGA). With this device, the signal subtraction, common mode noise rejection and some filtering of the differential input signal is performed inside the microcontroller. The PGA also allows for multiple input channels, which is configurable using the SPI™ port.

A large number of sensors can be configured to the PGA inputs. An example is shown in Figure 1.

The type of resistive sensor bridge, shown in Figure 1, is primarily used to sense pressure, temperature or load. An external A/D converter and the PGA can easily be used to convert the difference voltage from these resistor bridge sensors to usable digital words. A block diagram of Microchip's PGA is shown in Figure 2.

At the input of this device there is a multiplexer, which allows the user to interface to multiple inputs. This multiplexer is directly connected to the noninverting input of a wide bandwidth amplifier. The programmable closed loop gain of this amplifier is implemented using an on-chip resistor ladder. The eight programmable gains are, 1, 2, 4, 5, 8, 10, 16 and 32.

The multiplexer and high-speed conversion response of the PGA and A/D combination allows a differential input signal to be quickly sampled and converted into their 12-bit digital representation. The PIC® microcontroller subtracts the two signals from CH0 and CH1. While the subtraction of the two signals is implemented to calculate the sensor response, the lower frequency common mode noise is also eliminated.

Although it is simple to measure temperature in a stand-alone system without the help of the PGA, a variety of problems can be eliminated by implementing temperature sensing capability in a multiplexed environment. One of the main advantages is that a second signal path to the microcontroller can be eliminated, while still maintaining

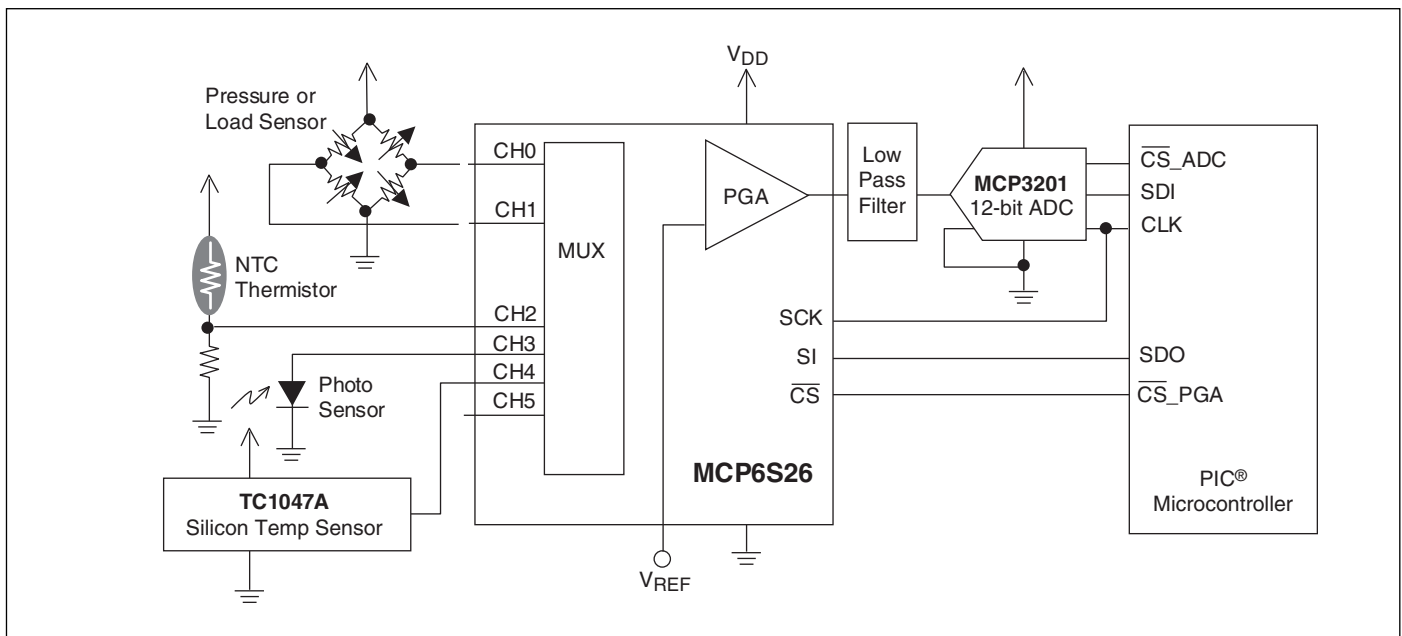

Figure 1. The PGA device can be used to gain signals from a variety of sensors, such as a resistive bridge, an NTC temperature sensor, a silicon photo sensor or a silicon temperature sensor.

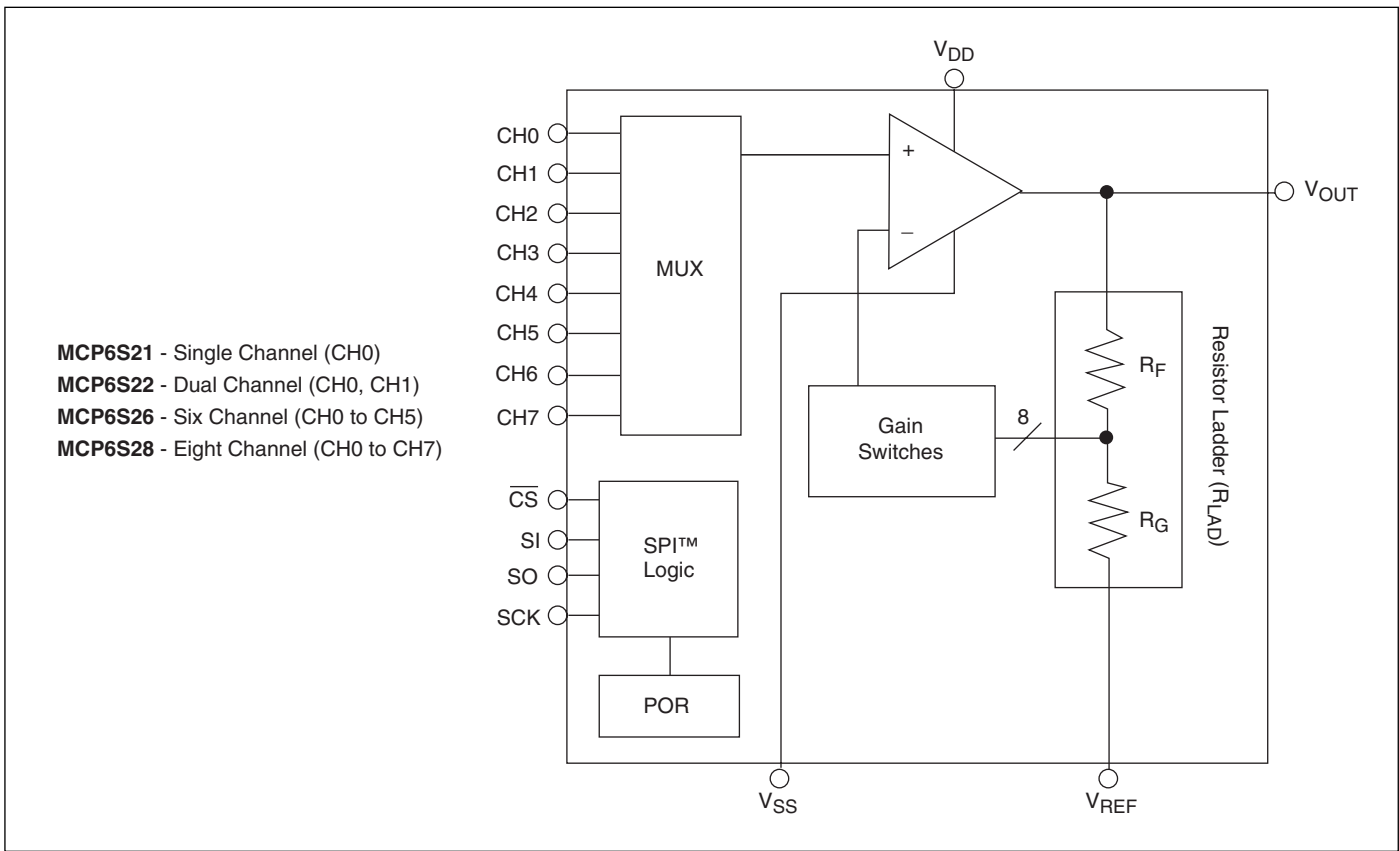

Figure 2. Programmable Gain Amplifier (PGA) Block Diagram. The PGA has an internal amplifier that is surrounded by a programmable resistor ladder. This ladder is used to change the gain through the SPI port. An analog multiplexer precedes the noninverting input of the amplifier to allow the user to configure this device from multiple inputs.

the accuracy of the sensing system. The multiplexed versions of PGAs are the MCP6S22 (two channel), MCP6S26 (six channel) and MCP6S28 (eight channel). The most common sensors for temperature measurements are the thermistor, silicon temperature sensor, RTD and thermocouple. Microchip's PGAs are best suited to interface to the thermistor or silicon temperature sensor. Photo sensors bridge the gap between light and electronics. The PGA is not well suited for precision applications such as, CT scanners, but they can be effectively used in position photo sensing applications. The multiplexer and high-speed conversion response of the PGA and A/D combination allows the photo sensor input signal to be sampled and converted in the analog domain and quickly converted to the digital domain. This photo sensing circuit is appropriate for signal responses from DC to ~100 kHz.

The MCP6S2X is a PGA family that uses a precision, wide bandwidth internal amplifier. This precision device not only offers excellent offset voltage performance, but the configurations in these sensing circuits are easily designed without the headaches of stability that the stand-alone amplifier circuits present to the designer. Stability with these programmable gain amplifiers has been built-in.

For more information, access the following list of references by visiting www.microchip.com.

Recommended References:

- AN248 *Interfacing MCP6S2X PGAs to PICmicro® Microcontroller*, Ezana Haile, Microchip Technology Inc.
- AN251 *Bridge Sensing with the MCP6S2X PGAs*, Bonnie C. Baker, Microchip Technology Inc.
- AN865 *Sensing Light with a Programmable Gain Amplifier*, Bonnie C. Baker, Microchip Technology Inc.
- AN867 *Temperature Sensing with a Programmable Gain Amplifier*, Bonnie C. Baker, Microchip Technology Inc.



For more information, please visit www.microchip.com