

Keeping Power Hungry Circuits Under Thermal Control



By Bonnie C. Baker, Microchip Technology Inc.

ANALOG DESIGN NOTE

ADN001

Introduction

Projectors, large power supplies, datacom switches and routers, pose an interesting heat dissipation problem. These applications consume enough power to prompt a designer to cool off the electronics with a fan. If the appropriate airflow across the electronics is equal to or less than six to seven cubic feet per minute (CFM), a good choice of fan would be the DC brushless fan.

The fan speed of a DC brushless fan can be driven and controlled by the electronics in a discrete solution, a microprocessor circuit or a stand-alone fan controller IC. A discrete solution can be highly customized but can be real-estate hungry. Although this solution is a low cost alternative, it is challenging to implement “smart” features, such as predictive fan failure or false fan failure alarm rejection. Additionally, the hardware troubleshooting phase for this system can be intensive as the feature set increases.

If you have a multiple fan application, the best circuit to use is a microcontroller-based system. With the microcontroller, all the fans and temperatures of the various environments can be economically controlled with this one chip solution and a few external components. The “smart” features that are difficult to implement with discrete solutions are easily executed with the microcontroller. The firmware of the microcontroller can be used to set threshold temperatures and fan diagnostics for an array of fans. Since the complexity of this system goes beyond the control of one fan, the firmware overhead and firmware debugging can be an issue.

For a one-fan circuit, the stand-alone fan controller IC is the better choice. The stand-alone IC has fault detect circuitry that can notify the system when the fan has failed, so that the power consuming part of the system can be shutdown. The stand-alone IC fan fault detection capability rejects glitches, ensuring that false alarms are filtered. It can economically be used to sense remote temperature with a NTC thermistor or with the internal temperature sensor on-chip. As an added benefit, the stand-alone IC can be used to detect the fan faults of a two-wire fan, which is more economical than its three-wire counterpart.

Regardless of the circuit option that is used, there are three primary design issues to be considered in fan control circuits, once the proper location of the fan is determined. These three design issues are: fan excitation, temperature monitoring and fan noise.

The circuit in Figure 1 illustrates how a two-wire fan can be driven with a stand-alone IC. In this circuit, the TC647B performs the task of varying the fan speed based on the temperature that is sensed from the NTC thermistor. The TC647B is also able to sense fan operation, enabling it to indicate when a fan fault has occurred.

The speed of a brushless DC fan can be controlled by either varying the voltage applied to it linearly or by pulse width modulating (PWM) the voltage. The TC647B shown in Figure 1, drives the base of transistor Q1 with a PWM waveform, which in turn drives the voltage that is applied to the fan.

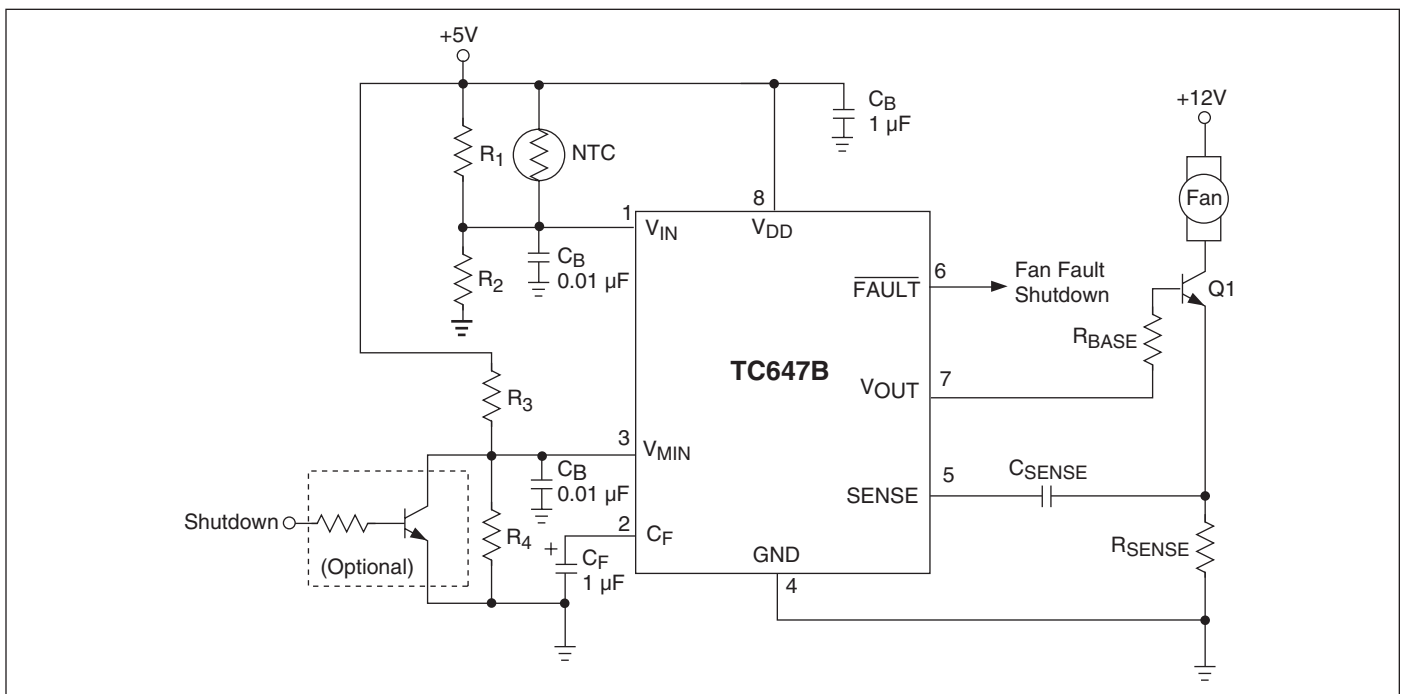

Figure 1. A two-wire fan can easily be driven and controlled by a thermistor-connected, TC647B

By varying the pulse width of the PWM waveform, the speed of the fan can be increased or decreased. The pulse width modulation method of fan speed control is more efficient than the linear regulation method.

The voltage across R_{SENSE} and the voltage at the SENSE pin during PWM mode operation are shown in Figure 2. The voltage at the sense resistor has both DC and AC content. The AC content is generated by the commutation of the current in the fan motor windings. These voltage transients across R_{SENSE} are coupled through C_{SENSE} to the SENSE pin of the TC647B. This removes the DC content of the sense resistor voltage. There is an internal resistor, 10 k Ω to ground, on the SENSE pin. The SENSE pin senses voltage pulses, which communicate fan operation to the TC647B. If pulses are not detected by the SENSE pin for one second, a fault condition is indicated by the TC647B.

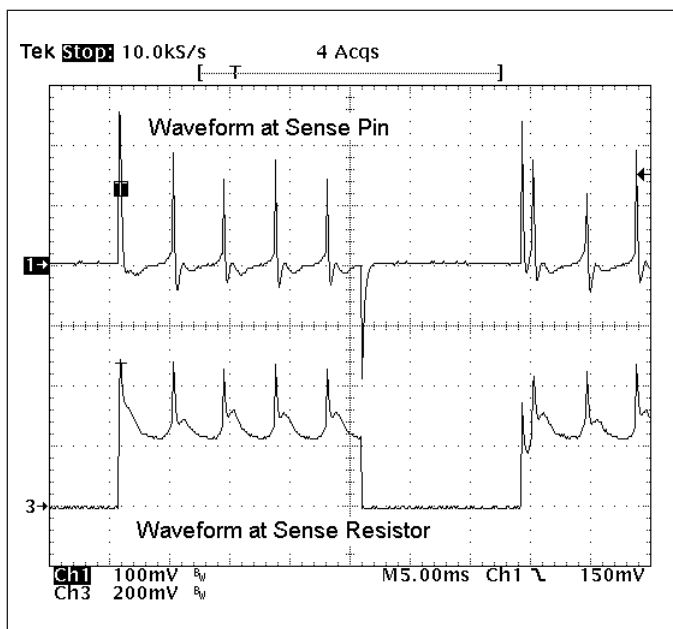

Figure 2. The fan response (across R_{SENSE}) to the PWM signal at V_{OUT} is shown in the bottom trace. The capacitively coupled signal to the SENSE pin of the TC647B is shown in the top trace.

The temperature can easily be measured with an economic solution, such as a thermistor. The thermistor is fast, small, requires a two-wire interface and has a wide range of outputs. As an added benefit, the layout flexibility is enhanced by being able to place the thermistor remote from the TC647B. Although thermistors are non-linear, they can be linearized over a smaller temperature range ($\pm 25^{\circ}\text{C}$) with the circuits shown in Figure 3. This linearization and level shifting is done using standard, 1% resistors.

Although temperature proportional fan speed control and fan fault detection for two-wire fans can be implemented in a discrete circuit or the microcontroller version, it requires a degree of attention from the designer. The TC647B is a switch mode two-wire brushless DC fan speed controller. Pulse Width Modulation (PWM) is used to control the speed of the fan in relation to the thermistor temperature. Minimum fan speed is set by a simple resistor divider on V_{MIN} . An integrated Start-up Timer ensures reliable motor start-up at turn-on, coming out of shutdown mode or following a transient fault with auto-fan restart capability.

The TC647B also uses Microchip's FanSense™ technology, which improves system reliability. All of these features included in a single chip, gives the designer a leg up in a single fan implementation.

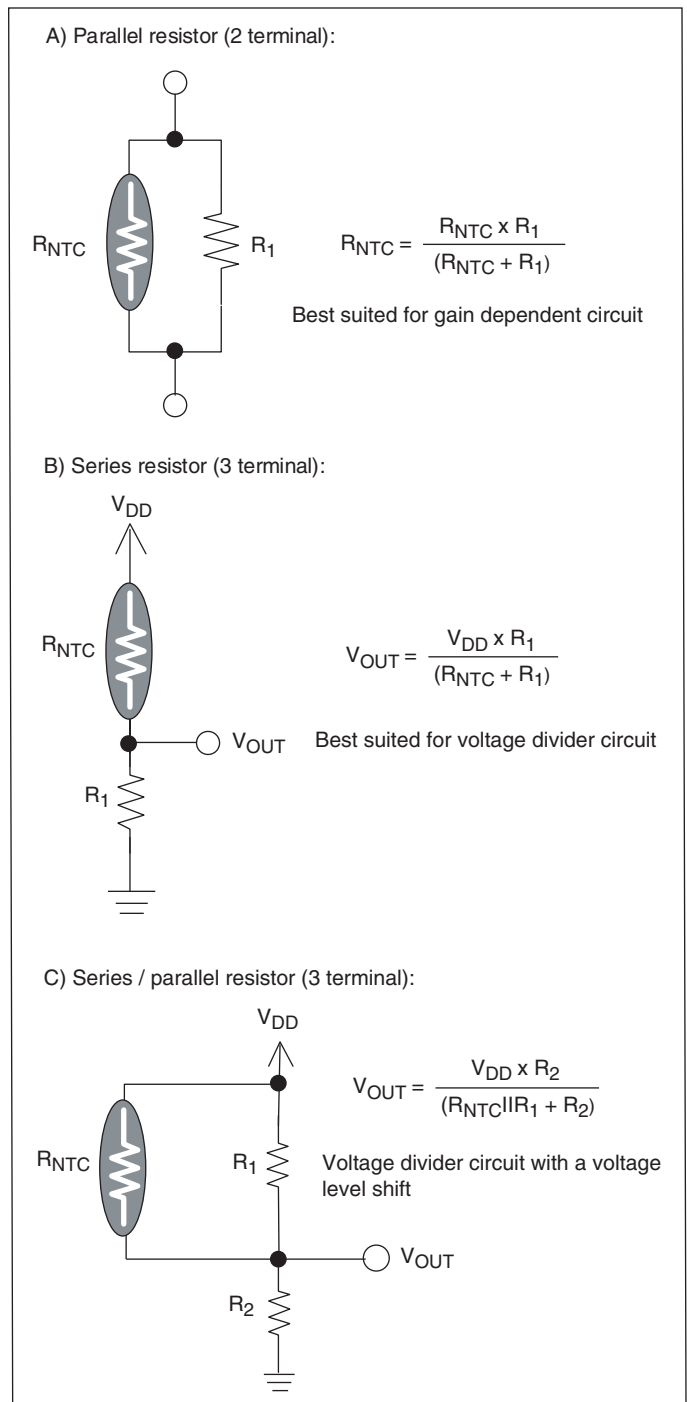

Figure 3. A thermistor can be linearized over 50°C with a standard resistor (A and B), as well as level shifted (C) to match the input requirements of the TC647B.



For more information, please visit www.microchip.com

The Microchip name and logo are registered trademarks of Microchip Technology Inc. in the U.S.A. and other countries. FanSense is a trademark of Microchip Technology Inc. in the U.S.A. © 2003 Microchip Technology Inc.