

Atmel®

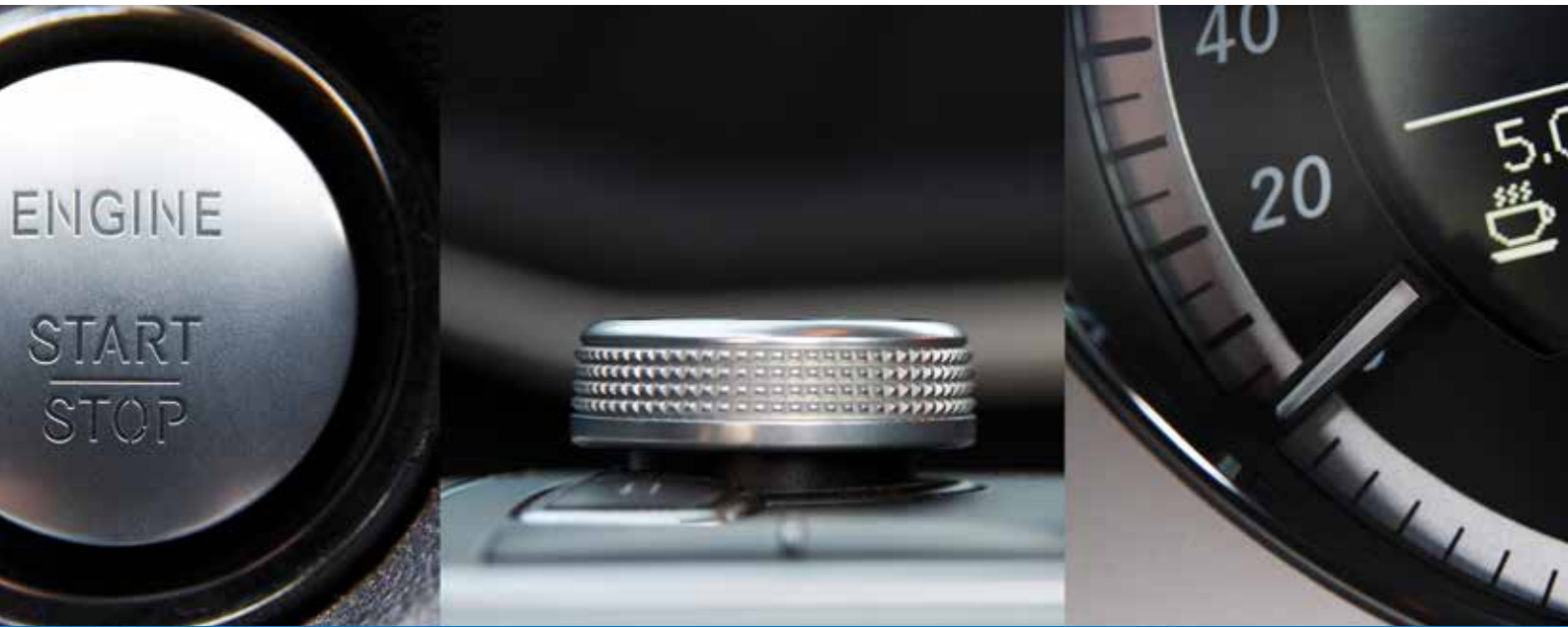

Atmel Automotive Solutions



The Atmel Automotive Commitment

As a global manufacturer of innovative integrated circuits, Atmel has about 30 years of automotive electronics design expertise and is a market leader in numerous automotive areas. Atmel develops a broad array of automotive-dedicated technologies, such as BCDMOS, Bipolar/CMOS/DMOS-on-Silicon On Insulator (BCD-on-SOI) and non-volatile CMOS. Automotive-qualified fabs (ISO 9001:2000, ISO TS 16949:2002, and ISO 14001:2004) enable Atmel to provide high-end products that not only meet strict automotive quality demands but also make vehicles safer, more economical and more convenient. Design-ins are supported by our application engineers, demonstration and evaluation kits, reference boards, software, and detailed documentation.

Atmel Automotive Products

Multiplexing and Standard Microcontrollers

- Atmel® AVR® 32-bit microcontrollers
- 8-bit AVR microcontrollers
- Networking (LIN, CAN)
- Capacitive touch microcontrollers

Body Electronics and Powertrain

- In-vehicle networking (IVN, including LIN, CAN and microcontrollers)
- Motor control (drivers, high temperature solutions, motor-driver system basis chips, microcontrollers)
- Watchdog ICs
- Li-ion battery management and replacement of standard lead-acid batteries

Automotive RF Solutions

- Car access

Car Radio Solutions

Serial EEPROMs

- 2-wire/I²C bus
- 3-wire/microwire bus
- SPI bus

Innovative Atmel AVR Microcontroller Solutions for Automotive Applications

Increasing consumer demands for comfort, safety, and reduced fuel consumption are driving rapid growth in the market for automotive electronics. All the new functions designed to meet these demands require local intelligence and control, which can be optimized by the use of small, powerful microcontrollers.

Atmel leverages its unsurpassed experience in embedded flash memory microcontrollers to bring innovative solutions for automotive applications. These include a wide range of AVR microcontrollers for everything from sensor or actuator control to more sophisticated networking applications. Atmel microcontrollers are fully engineered to fulfill the quality requirements of OEMs in their drive towards zero defects.

+150°C Qualified

Atmel AVR® microcontrollers are qualified for operation up to +150°C ambient temperature (AEC-Q100 Grade 0). These devices enable designers to distribute intelligence and control functions directly into or near gearboxes, transfer cases, engine sensors actuators, turbochargers and exhaust systems.

Automotive AVR solutions available in Grade 0 are the Atmel ATtiny45, ATtiny87/167, ATtiny261/ 461/861, ATmega88/168, ATmega16M1, ATmega32M1, ATmega32C1, ATmega64M1, and ATmega64C1.

Automotive AVR microcontrollers are available in two different temperature ranges to serve various applications:

- AEC-Q100 Grade 1 Z: -40°C to +125°C
- AEC-Q100 Grade 0 D, T2: -40°C to +150°C

Automotive: A Completely Distributed Architecture

Carmakers are continuously adding comfort and safety features to modern vehicles, resulting in the need for more embedded computing power. As cost-effective microcontrollers become available, carmakers now have the ability to design distributed architectures with scattered and reprogrammable 8-bit microcontrollers. Alternatively, they can merge all functions into one powerful 32-bit microcontroller with multiple peripherals and networking connections.

Atmel AVR Architecture Benefits: 8-/32-bit RISC Core: High Performance, Low-power Consumption

The AVR 8- and 32-bit architectures have reached a high level of acceptance in many market segments because they provide:

- Highest system integration with a large number of analog and digital peripherals
- Highest CPU performance with executing instructions in a single clock cycle
- Highest code density with high-level C-language optimization
- Dedicated Digital Signal Processor (DSP) and Floating Point Instructions (32-bit)
- Self-programming memory
- Product compatibility for both code and features
- Complete and low-cost tool set
- Brown-out detection and flash corruption security

AVR 8-bit microcontrollers are perfectly suited for distributed architectures. They feature on-chip analog interfaces for signal conditioning or programmable I/Os for actuator signaling, and Controller Area Network (CAN), Local Interconnect Network (LIN) or Pulse Wave Modulation (PWM) networking connections to the Electronic Control Unit (ECU).

Centralized architectures benefit from AVR 32-bit microcontrollers with their rich peripheral sets and multiple CAN and LIN connections.



Atmel Capacitive Touch Solutions

For HMI and Car Infotainment Applications

Capacitive touch solutions are entering the automotive market in integrated centerstacks, touch panels, navigation systems and radio HMI solutions. Atmel offers hardware and software library solutions for touch buttons, sliders and wheels as well as a sophisticated touchscreen controller portfolio addressing screens and pads of all common sizes up to 12 inches and more.

All touch controllers are based on Atmel's market-leading and patented charge transfer technology. They provide dedicated functionalities that meet the specific automotive requirements, such as high-temperature behavior, reliable operation in harsh environments and gloved operation.

The maXTouch® family comprises 4 touchscreen controllers with 143 to 768 nodes addressing different screen sizes, aspect ratios and sensor pitches. They deliver the X/Y coordinates of up to 16 touches via the I²C interface.

Atmel Automotive Solutions

mXT143E/ mXT224E Key Features

- Automotive grade 3: -40°C to +85°C
- 143 and 224 channels
- 12-bit resolution
- Support up to 7" screens
- Additional up to 32 channels touch keys
- Unintended touch suppression
- No additional parts needed
- Response time < 10ms from idle
- I²C host interface
- TQFP48 package

mXT540E/ mXT768E Key Features

- Automotive grade 2: -40°C to +105°C
- 540 and 768 channels
- 12-bit resolution
- Support up to 12" screens
- Additional up to 64 channels touch keys
- Unintended touch suppression
- No additional parts needed
- Response time < 10ms from idle
- I²C host interface
- TQFP100 package

Part Number	Description	Package
QT1110	11-channel Touch Controller for Touch Buttons	TQFP32 (7x7mm)
mXT143E-A	143-channel Touchscreen Controller, Automotive Grade 3, I ² C Interface	TQFP48 (7x7mm)
mXT224E-A	224-channel Touchscreen Controller, Automotive Grade 3, I ² C Interface	TQFP48 (7x7mm)
mXT540E-A	540-channel Touchscreen Controller, Automotive Grade 2, I ² C Interface	TQFP100 (14x14mm)
mXT768E-A	768-channel Touchscreen Controller, Automotive Grade 2, I ² C Interface	TQFP100 (14x14mm)

Meeting Customer Expectations

Features	Meeting Expectations
Capacitive touch technology supports proximity detection, touch buttons, slider, wheels and touchscreens	<ul style="list-style-type: none"> • On-stop shop • Totally integrated HMI
Unlimited, unambiguous touch identification, tracking and reporting	<ul style="list-style-type: none"> • Multi-touch support
Smart processing with integrated 32-bit MCU and DSP engine	<ul style="list-style-type: none"> • Integrated gesture calculation • Suppressing unintended touches
Embedded post-processing algorithms	<ul style="list-style-type: none"> • Adjacent key suppression • Noise filtering • Improved EMI/ESD behavior
Very fast response time < 10ms	<ul style="list-style-type: none"> • Supports character recognition
High SNR (signal-to-noise ratio): 80:1	<ul style="list-style-type: none"> • Fingertip, back of finger touches supported • Gloved finger operation



Standard Automotive Atmel AVR 8-bit Microcontrollers

Atmel Part Number	Flash (KB)	EEPROM (Bytes)	SRAM (Bytes)	I/O Pins	Vcc (V)	10-bit A/D Channels	Analog Comparator	Motor Ctl. Timer	16-bit Timer	8-bit Timer	Ext. Interrupts
CAN											
AT90CAN32	32	1024	2048	53	2.7-5.5	8	Yes		2	2	8
AT90CAN64	64	2048	4096	53	2.7-5.5	8	Yes		2	2	8
AT90CAN128	128	4096	4096	53	2.7-5.5	8	Yes		2	2	8
megaAVR											
ATmega48PA	4	256	512	23	2.7-5.5	8	Yes		1	2	26
ATmega88PA	8	512	1024	23	2.7-5.5	8	Yes		1	2	26
ATmega88V	8	512	1024	23	1.8-3.6	8	Yes		1	2	26
ATmega16M1	16	512	1024	27	2.7-5.5	11	4	1	1	1	27
ATmega164P	16	512	1024	32	2.7-5.5	8	Yes		1	2	32
ATmega168PA	16	512	1024	23	2.7-5.5	8	Yes		1	2	26
ATmega169P	16	512	1024	54	2.7-5.5	8	Yes		1	2	17
ATmega32C1	32	1024	2048	27	2.7-5.5	11	4		1	1	27
ATmega32M1	32	1024	2048	27	2.7-5.5	11	4	1	1	1	27
ATmega324P	32	1024	2048	32	2.7-5.5	8	Yes		1	2	32
ATmega328PA	32	1024	2048	23	2.7-5.5	8	Yes		1	2	26
ATmega644P	64	2048	4096	32	2.7-5.5	8	Yes		1	2	32
ATmega64C1	64	2048	4096	27	2.7-5.5	11	4		1	1	27
ATmega64M1	64	2048	4096	27	2.7-5.5	11	4	1	1	1	27
tinyAVR											
ATtiny1634	16	256	1024	18	2.7-5.5	12	Yes		1	1	18
ATtiny24	2	128	128	12	2.7-5.5	8	Yes		1	1	12
ATtiny25	2	128	128	6	2.7-5.5	4	Yes		--	2	7
ATtiny261	2	128	128	16	2.7-5.5	11	Yes		1	1 (10bit)	16
ATtiny44	4	256	256	12	2.7-5.5	8	Yes		1	1	12
ATtiny44V	4	256	256	12	1.8-3.6	8	Yes		--	1	12
ATtiny45	4	256	256	6	2.7-5.5	4	Yes		--	2	7
ATtiny45V	4	256	256	6	1.8-3.6	4	Yes		1	2	7
ATtiny461	4	256	256	16	2.7-5.5	11	Yes		1	1 (10bit)	16
ATtiny84	8	512	512	12	2.7-5.5	8	Yes		--	1	12
ATtiny85	8	512	512	6	2.7-5.5	4	Yes		--	2	7
ATtiny85V	8	512	512	6	1.8-3.6	4	Yes		1	2	7
ATtiny861	8	512	512	16	2.7-5.5	11	Yes		1	1 (10bit)	16
ATtiny87	8	512	512	16	2.7-5.5	11	Yes		1	1	16
ATtiny88	8	64	512	28	2.7-5.5	8	Yes		1	1	28
ATtiny167	16	512	512	16	2.7-5.5	11	Yes		1	1	16

All devices have a programmable brown-out controller, on-chip 8MHz RC oscillator and a watchdog. The maximum frequency is 16MHz.

Atmel Automotive Solutions

Hardware Multiplier	PWM Channels	RTC	Self Program Memory	CAN (Mess. Obj.)	SPI	TMI	UART (LIN/HW)	Packages	Max. Temp (°C)
Yes	8	Yes	Yes	1 (15)	Yes	--	2	VQFN64, LQFP64	125
Yes	8	Yes	Yes	1 (15)	Yes	--	2	VQFN64, LQFP64	125
Yes	8	Yes	Yes	1 (15)	Yes	--	2	VQFN64, LQFP64	125
Yes	6	Yes	Yes		1 + USART	Yes	1	TQFP32, VQFN32	125
Yes	6	Yes	Yes		1 + USART	Yes	1	TQFP32, VQFN32	125
Yes	6	Yes	Yes		1 + USART	Yes	1	TQFP32, VQFN32	85
Yes	10	--	Yes	1 (6)	Yes	--	1 (Y)	TQFP32, VQFN32	125
Yes	6	Yes	Yes		1 + USART	Yes	2	VQFN44, TQFP44	125
Yes	6	Yes	Yes		1 + USART	Yes	1	TQFP32, VQFN32	125
Yes	4	Yes	Yes		Yes	USI	1	VQFN64, TQFP64	85
Yes	4	--	Yes	1 (6)	Yes	--	1 (Y)	TQFP32, VQFN32	125
Yes	10	--	Yes	1 (6)	Yes	--	1 (Y)	TQFP32, VQFN32	125
Yes	6	Yes	Yes		1 + USART	Yes	2	VQFN44, TQFP44	125
Yes	6	Yes	Yes		1 + USART	Yes	1	TQFP32, VQFN32	125
Yes	6	Yes	Yes		1 + USART	Yes	2	VQFN32, TQFP44	125
Yes	4	--	Yes	1 (6)	Yes	--	1 (Y)	TQFP32, VQFN32	125
Yes	10	--	Yes	1 (6)	Yes	--	1 (Y)	TQFP32, VQFN32	125
--	4	--	Yes		1 + USI	2 (N)		VQFN20, TSSOP20	125
--	4	--	Yes		USI	USI	--	VQFN20, SOIC14	125
--	4	--	Yes		USI	USI	--	VQFN20, SOIC8	125
--	6	--	Yes		Yes	USI	--	VQFN32, VQFN20, SOIC20, TSSOP20	125
--	4	--	Yes		USI	USI	--	VQFN20, SOIC14	125
--	4	--	Yes		USI	USI	--	VQFN20, SOIC14	85
--	4	--	Yes		USI	USI	--	VQFN20, SOIC8	125
--	4	--	Yes		USI	USI	--	VQFN20, SOIC8	85
--	6	--	Yes		Yes	USI	--	VQFN32, VQFN20, SOIC20, TSSOP20	125
--	4	--	Yes		USI	USI	--	VQFN20	125
--	4	--	Yes		USI	USI	--	VQFN20, SOIC8	125
--	4	--	Yes		USI	USI	--	VQFN20, SOIC8	85
--	6	--	Yes		Yes	USI	--	VQFN32, VQFN20, SOIC20, TSSOP20	125
--	3	Yes	Yes		1 + USI	No	1 (Y)	VQFN32, SOIC20, TSSOP20	125
--	4	--	Yes		Yes	Yes		TQFP32, VQFN32	125
--	3	Yes	Yes		1 + USI	No	1 (Y)	VQFN32, SOIC20, TSSOP20	125



Automotive Atmel AVR 8-bit Microcontrollers Grade 0 (150°C)

Atmel Part Number	Flash (KB)	EEPROM (Bytes)	SRAM (Bytes)	I/O Pins	V _{CC} (V)	10-bit A/D Channels	Analog Comparator	Motor Ctrl. Timer	16-bit Timer	8-bit Timer	Ext. Interrupts
megaAVR											
ATmega88PA	8	512	1024	23	2.7-5.5	8	Yes		1	2	26
ATmega16M1	16	512	1024	27	2.7-5.5	11	4	1	1	1	27
ATmega168PA	16	512	1024	23	2.7-5.5	8	Yes		1	2	26
ATmega32C1	32	1024	2048	27	2.7-5.5	11	4		1	1	27
ATmega32M1	32	1024	2048	27	2.7-5.5	11	4	1	1	1	27
ATmega64C1	64	2048	4096	27	2.7-5.5	11	4		1	1	27
ATmega64M1	64	2048	4096	27	2.7-5.5	11	4	1	1	1	27
tinyAVR											
ATtiny261	2	128	128	16	2.7-5.5	11	Yes		1	1 (10bit)	16
ATtiny45	4	256	256	6	2.7-5.5	4	Yes		--	2	7
ATtiny461	4	256	256	16	2.7-5.5	11	Yes		1	1 (10bit)	16
ATtiny87	8	512	512	16	2.7-5.5	11	Yes		1	1	16
ATtiny861	8	512	512	16	2.7-5.5	11	Yes		1	1 (10bit)	16
ATtiny167	16	512	512	16	2.7-5.5	11	Yes		1	1	16

All devices have a programmable brown-out controller, on-chip 8MHz RC oscillator and a watchdog. The maximum frequency is 16MHz.

Automotive Atmel AVR 32-bit Microcontrollers

Atmel Part Number	Core (DMIPS)	Flash (KB)	SRAM (KB)	DMA	I/O Pins	V _{CC} (V)	ADC Channels	DAC Channels
UC3C0128	AVR32 (68)	128	32	16c & event system	123	3.0-3.6 / 4.5-5.5	12b 16c	12b 4c
UC3C1128	AVR32 (68)	128	32	16c & event system	81	3.0-3.6 / 4.5-5.5	12b 16c	12b 4c
UC3C2128	AVR32 (68)	128	32	16c & event system	45	3.0-3.6 / 4.5-5.5	12b 11c	12b 4c
UC3C0256	AVR32 (68)	256	64	16c & event system	123	3.0-3.6 / 4.5-5.5	12b 16c	12b 4c
UC3C1256	AVR32 (68)	256	64	16c & event system	81	3.0-3.6 / 4.5-5.5	12b 16c	12b 4c
UC3C2256	AVR32 (68)	256	64	16c & event system	45	3.0-3.6 / 4.5-5.5	12b 11c	12b 4c
UC3C0512	AVR32 (68)	512	64	16c & event system	123	3.0-3.6 / 4.5-5.5	12b 16c	12b 4c
UC3C1512	AVR32 (68)	512	64	16c & event system	81	3.0-3.6 / 4.5-5.5	12b 16c	12b 4c
UC3C2512	AVR32 (68)	512	64	16c & event system	45	3.0-3.6 / 4.5-5.5	12b 11c	12b 4c
UC3A0512	AVR32 with MPU (91)	512	64	15c	109	3.0-3.6 (5V tolerant)	10b 8c	Audio DAC

All devices have a programmable brown-out controller, on-chip 8MHz RC oscillator and a watchdog. The maximum frequency is 66MHz (UC3A0512) and 50MHz (all others).

Atmel Automotive Solutions

Hardware Multiplier	PWM Channels	RTC	Self Program Memory	CAN (Mess. Obj.)	SPI	TWI	UART (LIN HW)	Packages	Max. Temp. (°C)
Yes	6	Yes	Yes		1 + USART	Yes	1	TQFP32, VQFN32	150
Yes	10	--	Yes	1 (6)	Yes	--	1 (Y)	TQFP32, VQFN32	150
Yes	6	Yes	Yes		1 + USART	Yes	1	TQFP32, VQFN32	150
Yes	4	--	Yes	1 (6)	Yes	--	1 (Y)	TQFP32, VQFN32	150
Yes	10	--	Yes	1 (6)	Yes	--	1 (Y)	TQFP32, VQFN32	150
Yes	4	--	Yes	1 (6)	Yes	--	1 (Y)	TQFP32, VQFN32	150
Yes	10	--	Yes	1 (6)	Yes	--	1 (Y)	TQFP32, VQFN32	150
--	6	--	Yes		Yes	USI	--	VQFN32, VQFN20, SOIC20, TSSOP20	150
--	4	--	Yes		USI	USI	--	VQFN20, SOIC8	150
--	6	--	Yes		Yes	USI	--	VQFN32, VQFN20, SOIC20, TSSOP20	150
--	3	Yes	Yes		1 + USI	No	1 (Y)	VQFN32, SOIC20, TSSOP20	150
--	6	--	Yes		Yes	USI	--	VQFN32, VQFN20, SOIC20, TSSOP20	150
--	3	Yes	Yes		1 + USI	No	1 (Y)	VQFN32, SOIC20, TSSOP20	150

Analog Comparator	16-bit Timer	Extended Timers	Ext. Interrupts	DSP Instructions	RTC	CAN (Mailboxes)	Ethernet	USB	USART (LIN HW)	SPI	TWI	I ² S	EBI	Package	Max. Temp. (°C)
4	6	20b 4c motor control	8	Y & FPU	Y	2 (16)	1	FS	5 (5)	2	3	1	Y	LQFP144	125
4	6	20b 4c motor control	8	Y & FPU	Y	2 (16)	1	FS	5 (5)	2	3	1	-	TQFP100	125
2	3	20b 4c motor control	8	Y & FPU	Y	2 (16)	1	FS	4 (4)	1	2	1	-	TQFP64/QFN64	125
4	6	20b 4c motor control	8	Y & FPU	Y	2 (16)	1	FS	5 (5)	2	3	1	Y	LQFP144	125
4	6	20b 4c motor control	8	Y & FPU	Y	2 (16)	1	FS	5 (5)	2	3	1	-	TQFP100	125
2	3	20b 4c motor control	8	Y & FPU	Y	2 (16)	1	FS	4 (4)	1	2	1	-	TQFP64/QFN64	125
4	6	20b 4c motor control	8	Y & FPU	Y	2 (16)	1	FS	5 (5)	2	3	1	Y	LQFP144	125
4	6	20b 4c motor control	8	Y & FPU	Y	2 (16)	1	FS	5 (5)	2	3	1	-	TQFP100	125
2	3	20b 4c motor control	8	Y & FPU	Y	2 (16)	1	FS	4 (4)	1	2	1	-	TQFP64/QFN64	125
-	3	20bit 7c PWM	8	Y	Y	-	1	FS-OTG	4 (0)	2	1	1	Y	LQFP144	85

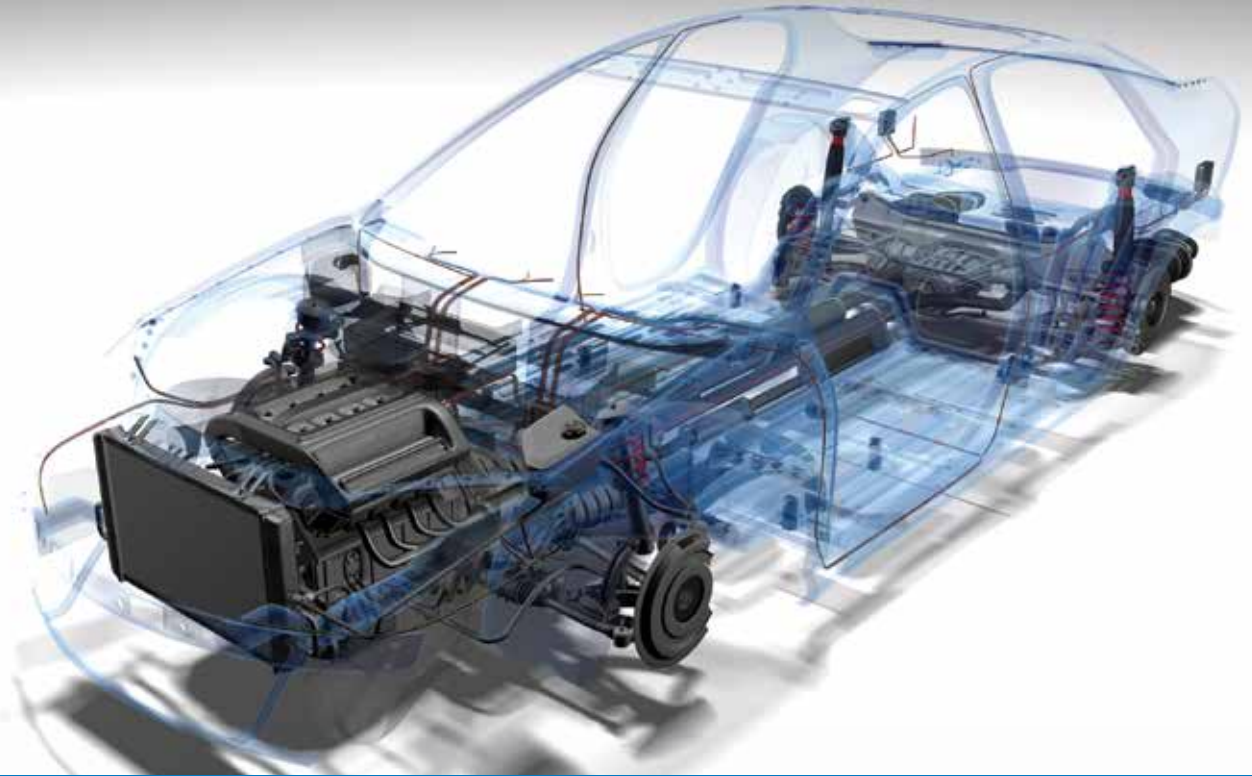

Body Electronics and Powertrain

With 30 years experience in body electronic and powertrain designs, Atmel is a market leader in numerous areas. In the ever-growing LIN bus system segment, Atmel offers products at all integration levels—from simple transceiver ICs to complex system basis chips (SBC). At higher integration levels, Atmel provides complete System-in-Package (SIP) solutions, including an Atmel AVR microcontroller, LIN transceiver, voltage regulator and watchdog in one single package.

The advantages of silicon on insulator (SOI) technology make it possible to develop ICs with outstanding electromagnetic immunity (EMI and ESD). Atmel is committed to offering its customers optimal LIN solutions as the LIN area continues to develop and evolve. Atmel driver ICs are capable of handling environmental temperatures of 150°C and junction temperatures of 200°C, making their use possible in most high-temperature automotive applications.

With few external components, Atmel driver ICs with LIN communication and AVR microcontrollers combine to create cost-efficient motor driver modules complete with LIN functionality, which can equally be used in harsh automotive conditions.

- In-Vehicle Networking (IVN, including LIN, CAN, and microcontrollers)
- Standard and high-temperature drivers, motor-driver system basis chips
- Watchdogs
- Li-ion battery management and replacement of standard lead-acid batteries

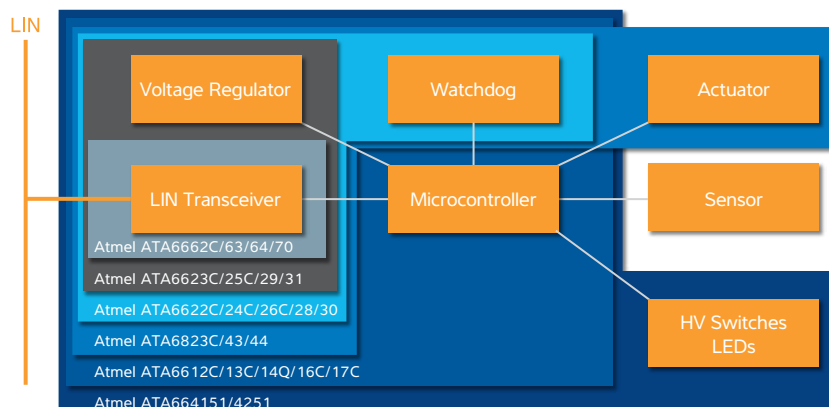

In-Vehicle Networking ICs

The modular Atmel LIN family includes simple transceiver ICs (Atmel ATA6662C/63/64/70), complex system basis chips (Atmel ATA6622C/23C/24C/25C/26C/28/29/30/31) and system-in-package modules (Atmel ATA6612C/13C/14Q/16C/17C) with complete system integration and advanced LIN ASSPs (ATA664151/4251) as well as system basis chips for motor-driver applications (ATA6823C/43/44).

LIN Family ICs

Part No.	Description	Package
ATA6612C	Atmel AVR LIN SiP, ATmega88 Microcontroller with LIN Transceiver, 5V Voltage Regulator, and Window Watchdog in Single Package	QFN48
ATA6613C	Atmel AVR LIN SiP, ATmega168 Microcontroller with LIN Transceiver, 5V Voltage Regulator, and Window Watchdog in Single Package	QFN48
ATA6614Q	AVR LIN SiP, ATmega328P Microcontroller with LIN Transceiver, 5V Voltage Regulator, and Window Watchdog in Single Package	QFN48
ATA6616C	Atmel AVR LIN SiP, ATtiny87 Microcontroller with LIN Transceiver, 5V Voltage Regulator, Window Watchdog and Hardware LIN UART in Tiny Single Package	QFN32
ATA6617C	Atmel AVR LIN SiP, ATtiny167 Microcontroller with LIN Transceiver, 5V Voltage Regulator, Window Watchdog and Hardware LIN UART in Tiny Single Package	QFN32
ATA6622C	LIN System Basis Chip with LIN Transceiver, Integrated 3.3V/50mA Voltage Regulator and Window Watchdog	QFN20
ATA6623C	LIN System Basis Chip with LIN Transceiver and Integrated 3.3V/50mA Voltage Regulator	SO8
ATA6624C	LIN System Basis Chip with LIN Transceiver, Integrated 5V/50mA Voltage Regulator and Window Watchdog	QFN20
ATA6625C	LIN System Basis Chip with LIN Transceiver and Integrated 5V/50mA Voltage Regulator	SO8
ATA6626C	LIN System Basis Chip Including LIN Transceiver without TxD Time-out Timer, Integrated 5V/50mA Voltage Regulator and Window Watchdog	QFN20
ATA6628	LIN System Basis Chip with LIN Transceiver, Integrated 3.3V/50mA Voltage Regulator and Window Watchdog	QFN20
ATA6629	LIN System Basis Chip with LIN Transceiver and Integrated 3.3V/50mA Voltage Regulator	SO8
ATA6630	LIN System Basis Chip with LIN Transceiver, Integrated 3.3V/50mA Voltage Regulator and Window Watchdog	QFN20
ATA6631	LIN System Basis Chip with LIN Transceiver and Integrated 3.3V/50mA Voltage Regulator	SO8
ATA664151	LIN System Basis Chip with LIN Transceiver, 5V Regulator, Watchdog, 8-channel High Voltage Switch/LED Interface with High-voltage Current Sources, 16-bit SPI	QFN32
ATA664251	16K Flash Microcontroller with LIN Transceiver, 5V Regulator, Watchdog, 8-channel High Voltage Switch / LED Interface with High-voltage Current Sources, 16-bit SPI	QFN48
ATA6662C	LIN Transceiver, Physical Layer According to Specification 2.1	SO8
ATA6663	LIN Transceiver, Physical Layer According to Specification 2.1	SO8, DFN8
ATA6664	LIN Transceiver, Physical Layer According to Specification 2.1, without Time-out Feature	SO8
ATA6670	Fully Integrated Dual-LIN Transceiver Complying to LIN Specification 2.0, 2.1 and SAEJ2602, with Advanced EMI/ESD Performance and TXD-dominant Time-out Feature	DFN14
ATA6823C	LIN System Basis Chip with H-bridge DC Motor Driver. Integrated 3.3V/5V/100mA Power Supply, LIN Transceiver, Watchdog	QFN32
ATA6843	30V BLDC Motor System Basis Chip, LIN Interface, Window Watchdog and Voltage Regulator, Coast Function	QFN48
ATA6844	30V BLDC Motor System Basis Chip, LIN Interface, Window Watchdog and Voltage Regulator, T _{junction} up to 200°C, Coast Function	QFN48

High-Temperature Drivers

Atmel driver ICs are available for high-temperature applications in mechatronic solutions such as turbocharger or exhaust gas recirculation systems. Many flaps have to be controlled by DC motor driver ICs, which are located very close to the hot engine. Due to the advantages of our proprietary Silicon-on-Insulator (SOI) technology (Atmel SMART-I.S.®), these driver ICs can withstand ambient temperatures up to 150°C/302°F and chip temperatures up to 200°C/392°F.



High-Temperature Drivers

Part No.	Description	Package
ATA6824	H-bridge DC Motor Driver System Basis Chip. Integrated 3.3V/5V / 100mA Power Supply, Window Watchdog and Serial Interface	QFN32, TQFP32
ATA6832	Triple Half-bridge Driver with 3 High-side and 3 Low-side Drivers, 1000mA Current Limitation and PWM > 20kHz	QFN18
ATA6844	30V BLDC Motor System Basis Chip with 3 Half-bridge Gate Drivers, LIN Interface, Window Watchdog and Voltage Regulator, T _{junction} up to 200°C, Coast Function	QFN48

Standard Driver ICs

Part No.	Description	Package
ATA6823	LIN System Basis Chip with H-bridge DC Motor Driver. Integrated 3.3V/5V/100mA Power Supply, LIN Transceiver, Watchdog, 2 High-side and 2 Low-side Gate Drivers	QFN32
ATA6826	Triple Half-bridge Driver with Serial Input Control, 3 High-side and 3 Low-side Drivers, 1000mA Current Limitation	SO14
ATA6831	Triple Half-bridge Driver with Serial Input Control and 25-kHz PWM Input, 3 High-side and 3 Low-side Drivers, 1000mA Current Limitation	QFN18
ATA6836	Hex Half-bridge Driver with Serial Input Control, 6 High-side and 6 Low-side Drivers, 650mA Current Limitation	SO28, QFN24
ATA6838	Hex Half-bridge Driver with Serial Input Control, 6 High-side and 6 Low-side Drivers, 950mA Current Limitation	QFN24
ATA6843	30V BLDC Motor System Basis Chip, LIN Interface, Window Watchdog and Voltage Regulator, Coast Function	QFN48



Battery Solutions

Li-ion Battery Management

With the ATA6870, Atmel provides a measurement and monitoring circuit designed for high-cell-count Li-ion battery systems in industrial and automotive applications such as electrical and hybrid electrical vehicles, ebikes or uninterruptible power supplies. It monitors the battery-cell voltage and the battery-cell temperature with a 12-bit ADC. The circuit also provides active and passive charge-balancing capability for each battery cell. Up to 16 circuits (96 cells) can be cascaded in one string.

Intelligent Battery Sensor

The Atmel megaAVR® ATmega32HVE2 and ATmega64HVE2 MCUs improve the performance and longevity of 12V standard lead-acid batteries. Designed for intelligent battery sensor applications, the devices determine the state of charge and state of health for 12V standard lead-acid batteries by measuring the battery voltage, current and temperature. For cars with idle-stop-go function, this feature is mandatory to retain sufficient battery energy for a guaranteed engine start. Combined with the Atmel ATA6870 Li-ion battery monitor IC, it forms an ideal system solution for replacing 12V standard lead-acid batteries with Li-ion batteries.

Part No.	Description	Package
ATA6870	Battery-cell Measuring, Power Supply and Charge Balancing Circuit for Multi-cell Li-ion Battery Stacks	QFN48
ATmega32HVE2/ ATmega64HVE2	Intelligent Battery Sensor System with Two 17/18bit $\Sigma\Delta$ ADCs, Programmable Gain Amplifier, Power Supply, LIN Trx, 8bit AVR Core with 32bit Math. Extension and 32k/64k Flash Memory	QFN48

Stand-alone Body Electronic ICs

Watchdog ICs

Part No.	Description	Package
ATA6020	Watchdog IC, Programmable via Metal Mask (Based on the Atmel ATAR080 Microcontroller)	SO20
ATA5021	Watchdog Timer, Active and Sleep Mode, 1 Wake-up Input, Enable Output	SO8



Automotive RF Solutions

Car Access

Having launched its first dedicated car access Atmel continues to recognize the importance of security in the automotive area. Atmel offers a comprehensive range of car access solutions from immobilizers to full-duplex transceivers perfect for the prevention of automotive theft. The Atmel automotive safety

portfolio also features extremely secure Passive Entry Go (PEG) solutions. In fact, Atmel provides all the devices needed to design a complete car access system. Customers have the flexibility to create their own dedicated designs using the low-power Atmel transmitter IC, receiver IC, and microcontroller families.

Uni-directional System

RF link for the keyless entry function to open or lock the doors. The immobilizer system is built with a bi-directional Low Frequency (LF) link operating with the AUT64 crypto algorithm.

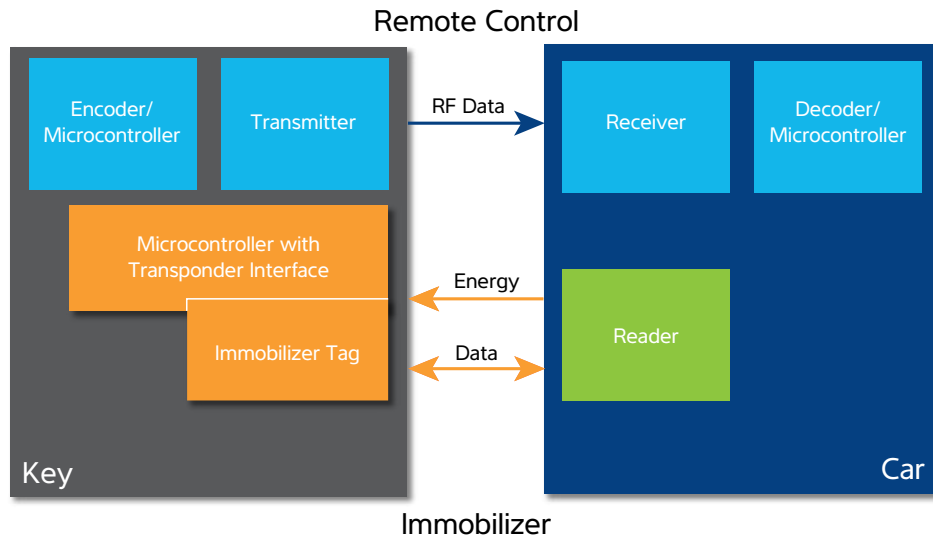

Bi-directional System and Wake-up Channel for Passive EntryGo Solution

RF link for the Remote Keyless Entry (RKE) function as well as for the extremely secure duplex RF link in a Passive Entry Go system. The LF link is used for the wake-up channel in a PEG system as well as for the immobilizer function to start the RF communication.

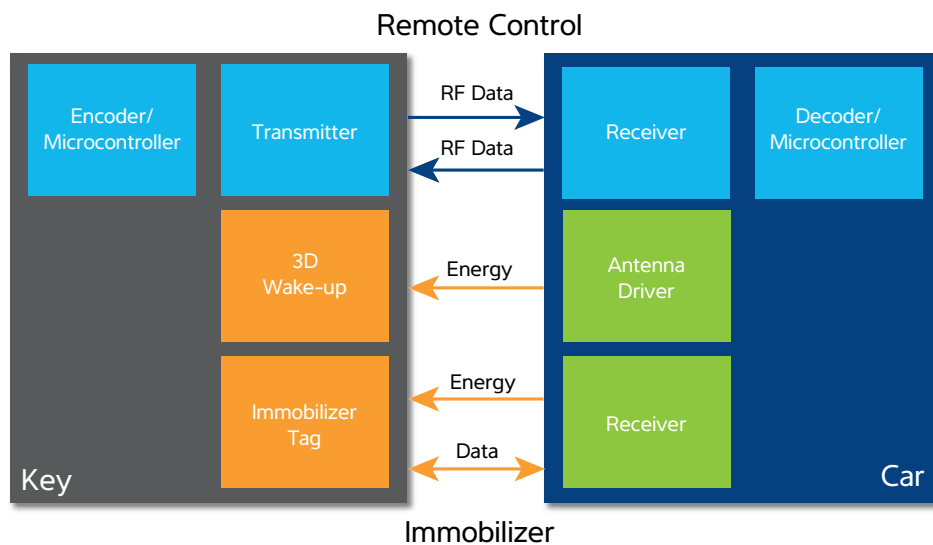



Car Access Devices

Part No.	Frequency Range	Modulation	Description	Package
ATA5279C	105–155kHz	ASK/FSK	Six-fold LF Antenna Driver IC	QFN48
ATA5580	125kHz	Bi-phase, Manchester, QPLM	AES-128-based Read/Write Immobilizer Transponder Incorporating Low-power AVR MCU	Plastic/Brick
ATA5723C	315MHz	ASK/FSK	UHF Remote Control Receiver, 300kHz Bandwidth RSSI Pin Compatible to ATA5724, ATA5728	SSO20
ATA5724C	433MHz	ASK/FSK	UHF Remote Control Receiver, 300kHz Bandwidth, RSSI Pin Compatible to ATA5723, ATA5728	SSO20
ATA5728C	868MHz	ASK/FSK	UHF Remote Control Receiver, 600kHz Bandwidth, RSSI Pin Compatible to ATA5723, ATA5724	SSO20
ATA5745C ATA5746C	433MHz 315MHz	ASK/FSK	Transparent UHF Receiver IC with Fast RKE/TPMS Switching Rate, Suited to 1 to 20Kbits/s Manchester FSK with 4 Programmable Bit-rate Ranges, High FSK Sensitivity (–114dBm at 2.4Kbits/s), High Blocking Capability	QFN24
ATA5749C	315–433MHz	ASK/FSK	Low-current Fully Integrated Fractional-N PLL Transmitter with Scalable Output Power (–0.5 to 12.5dBm)	TSSOP10
ATA5756C ATA5757C	315MHz 433MHz	ASK/FSK	UHF Transmitter ICs with Low Settling Time and Active Current Consumption	TSSOP10
ATA5771C ATA5773C ATA5774C	868–928MHz 315MHz 433MHz	ASK/FSK	AVR Microcontroller-based RF Transmitter Family	QFN24
ATA5780N	310–318MHz, 418–477MHz, 836–928MHz	ASK/FSK	Highly Sensitive UHF ASK/FSK Receiver	QFN32
ATA5790N	125kHz	BPLM*/ QPLM**/ Manchester/ Biphase	AES-128-based Passive Entry Go (PEG) IC for the Key, Including an Embedded Ultra-low-power AVR 8-bit Microcontroller, an LF Hardware AES Module for Immobilization, and a 3D LF Receiver Module	QFN38
ATA5791	315MHz, 433MHz	ASK/FSK Manchester	AES-128-based Embedded AVR Microcontroller Including RF Transmitter and Complete LF Functionality for Passive Entry/ Passive Start Keys	QFN38
ATA5795C	125kHz 315–433 MHz	BPLM*/ QPLM**/ Manchester/ Biphase ASK/FSK	AES-128-based Remote Keyless Entry (RKE) IC for the Key, Including an Embedded Ultra-low-power AVR 8-bit Microcontroller, the Dedicated RF Transmitter ATA5749C and the LF Hardware AES Module for Immobilization in a Single Package	QFN32
ATA5811C ATA5812C	433.868MHz 315MHz	ASK/FSK	UHF Transceiver IC with Extremely Low Current Consumption and Small Size	QFN48
ATA5823C ATA5824C	312.5–317.5MHz 433–868MHz	ASK/FSK	UHF Multi-channel Half-/Full-duplex Transceiver with Low Power Consumption	QFN48
ATA5830N	310–318MHz, 418–477MHz, 836–928MHz	ASK/FSK	Highly Sensitive UHF ASK/FSK Transceiver, Maximum Power-down Current 600nA	QFN32
ATA5831 ATA5832 ATA5833	433.92MHz	ASK/FSK	MCU-based RF Transceiver ICs Featuring Lowest Power Consumption and High Sensitivity	QFN32
T5750C T5753C T5754C	868–928MHz 310–330MHz 429–439MHz	ASK/FSK	UHF Transmitter IC with High Output Power and Wide Temperature Range (–40°C/F to +85°C/185°F, +125°C/257°F)	TSSOP8

*BPLM = Binary Pulse Length Modulation **QPLM = Quad Pulse Length Modulation

Serial EEPROMs

Atmel automotive-grade serial EEPROM products were first introduced in 1996. Over the years, Atmel has integrated rigorous quality and reliability systems into every step of the automotive manufacturing flow, while continuing to provide highly competitive solutions and keep pace with customers' demand. This enables Atmel to maintain the premier quality and delivery standards mandated by international automotive

customers. Within its extensive product portfolio, Atmel offers automotive-grade serial products in 2-wire, 3-wire, and Serial Programming Interface (SPI) bus protocols in Small-Outline Integrated Circuit (SOIC), Thin Shrink Small Outline Package (TSSOP), and Plastic Dual In-Line Packages (PDIP), all available in environmentally friendly versions.

Safety	2-wire Bus	3-wire Bus	SPI Bus
Airbags		AT93C46DN-SP25-T AT93C46-10TQ-2.7 AT93C56B-SSPD-T AT93C56B-XPDP-T AT93C66B-SSPD-T AT93C66B-XPDP-T AT93C86A-10SQ-2.7 AT93C86A-10TQ-2.7	AT25020B-SSPD-T AT25020B-XPDP-T AT25040B-SSPD-T AT25040B-XPDP-T AT25080B-SSPD-T AT25080B-XPDP-T AT25160B-SSPD-T AT25160B-XPDP-T AT25320B-SSPD-T AT25320B-XPDP-T AT25640B-SSPD-T AT25640B-XPDP-T AT25128B-SSPD-T AT25128B-XPDP-T AT25256B-SSPD-T AT25256B-XPDP-T
Anti-lock Brake Systems	AT24C02C-SSPD-T AT24C02C-XPDP-T AT24C04C-SSPD-T AT24C04C-XPDP-T	AT93C46DN-SP25-T AT93C46-10TQ-2.7 AT93C56B-SSPD-T AT93C56B-XPDP-T AT93C66B-SSPD-T AT93C66B-XPDP-T AT93C86A-10SQ-2.7 AT93C86A-10TQ-2.7	AT25040B-SSPD-T AT25040B-XPDP-T AT25080B-SSPD-T AT25080B-XPDP-T AT25160B-SSPD-T AT25160B-XPDP-T AT25320B-SSPD-T AT25320B-XPDP-T AT25640B-SSPD-T AT25640B-XPDP-T AT25128B-SSPD-T AT25128B-XPDP-T AT25256B-SSPD-T AT25256B-XPDP-T
Engine Control		AT93C56B-SSPD-T AT93C56B-XPDP-T AT93C66B-SSPD-T AT93C66B-XPDP-T AT93C86A-10SQ-2.7 AT93C86A-10TQ-2.7	AT25040B-SSPD-T AT25040B-XPDP-T AT25080B-SSPD-T AT25080B-XPDP-T AT25160B-SSPD-T AT25160B-XPDP-T AT25128B-SSPD-T AT25128B-XPDP-T AT25256B-SSPD-T AT25256B-XPDP-T



Serial EEPROMs (Continued)

Safety	2-wire Bus	3-wire Bus	SPI Bus
TPMS System	AT24C01C-SSPD-T AT24C01C-XPDP-T AT24C02C-SSPD-T AT24C02C-XPDP-T AT24C04C-SSPD-T AT24C04C-XPDP-T AT24C08C-SSPD-T AT24C08C-XPDP-T AT24C16C-SSPD-T AT24C16C-XPDP-T	AT93C46DN-SP25-T AT93C46-10TQ-2.7 AT93C56B-SSPD-T AT93C56B-XPDP-T AT93C66B-SSPD-T AT93C66B-XPDP-T AT93C86A-10SQ-2.7 AT93C86A-10TQ-2.7	AT25010B-SSPD-T AT25010B-XPDP-T AT25020B-SSPD-T AT25020B-XPDP-T AT25040B-SSPD-T AT25040B-XPDP-T
Accessories	2-wire Bus	3-wire Bus	SPI Bus
Audio	AT24C08C-SSPD-T AT24C08C-XPDP-T AT24C16C-SSPD-T AT24C16C-XPDP-T AT24C32D-SSPD-T AT24C32D-XPDP-T AT24C64D-SSPD-T AT24C64D-XPDP-T	AT93C46DN-SP25-T AT93C46-10TQ-2.7 AT93C56B-SSPD-T AT93C56B-XPDP-T AT93C66B-SSPD-T AT93C66B-XPDP-T AT93C86A-10SQ-2.7 AT93C86A-10TQ-2.7	
Dashboard	AT24C01C-SSPD-T AT24C01C-XPDP-T AT24C02C-SSPD-T AT24C02C-XPDP-T AT24C04C-SSPD-T AT24C04C-XPDP-T AT24C08C-SSPD-T AT24C08C-XPDP-T AT24C16C-SSPD-T AT24C16C-XPDP-T	AT93C46DN-SP25-T AT93C46-10TQ-2.7 AT93C56B-SSPD-T AT93C56B-XPDP-T AT93C66B-SSPD-T AT93C66B-XPDP-T AT93C86A-10SQ-2.7 AT93C86A-10TQ-2.7	AT25020B-SSPD-T AT25020B-XPDP-T AT25040B-SSPD-T AT25040B-XPDP-T AT25080B-SSPD-T AT25080B-XPDP-T AT25128B-SSPD-T AT25128B-XPDP-T AT25160B-SSPD-T AT25160B-XPDP-T
Driver Information and Assistance	AT24C01C-SSPD-T AT24C01C-XPDP-T AT24C02C-SSPD-T AT24C02C-XPDP-T AT24C04C-SSPD-T AT24C04C-XPDP-T AT24C08C-SSPD-T AT24C08C-XPDP-T AT24C16C-SSPD-T AT24C16C-XPDP-T	AT93C46DN-SP25-T AT93C46-10TQ-2.7 AT93C56B-SSPD-T AT93C56B-XPDP-T AT93C66B-SSPD-T AT93C66B-XPDP-T AT93C86A-10SQ-2.7 AT93C86A-10TQ-2.7	AT25010B-SSPD-T AT25010B-XPDP-T AT25020B-SSPD-T AT25020B-XPDP-T AT25040B-SSPD-T AT25040B-XPDP-T AT25080B-SSPD-T AT25080B-XPDP-T AT25160B-SSPD-T AT25160B-XPDP-T
TPMS System	AT24C08C-SSPD-T AT24C08C-XPDP-T AT24C16C-SSPD-T AT24C16C-XPDP-T AT24C32D-SSPD-T AT24C32D-XPDP-T AT24C64D-SSPD-T AT24C64D-XPDP-T AT24C128C-SSPD-T AT24C128C-XPDP-T AT24C256C-SSPD-T AT24C256C-XPDP-T	AT93C46DN-SP25-T AT93C46-10TQ-2.7 AT93C56B-SSPD-T AT93C56B-XPDP-T AT93C66B-SSPD-T AT93C66B-XPDP-T AT93C86A-10SQ-2.7 AT93C86A-10TQ-2.7	AT25080B-SSPD-T AT25080B-XPDP-T AT25160B-SSPD-T AT25160B-XPDP-T AT25320B-SSPD-T AT25320B-XPDP-T AT25640B-SSPD-T AT25640B-XPDP-T AT25128B-SSPD-T AT25128B-XPDP-T AT25256B-SSPD-T AT25256B-XPDP-T



Atmel Car Radio Solutions

Atmel has over 30 years experience in designing broadcast radio solutions. The company's in-depth know-how and high quality standards (ISO9001 and ISO16949) make it possible to achieve the stringent quality and performance requirements of the car radio market.

Today, Atmel is recognized for offering IC solutions with maximum performance, flexibility and integration levels required for the rapidly expanding AM/FM active antenna market. Atmel antenna devices can be used in any antenna regardless of design type—pole, shark fin, short pole or glass/window antenna.

Active Antenna ICs

Part No.	Description	Package
ATR4251	Low-noise AM/FM Antenna Amplifier with AGC Function at AM and FM, and Large AM Frequency Range	SSO20 QFN24
ATR4252	All-in-one IC Solution for Active Antennas	QFN28
ATR4253	Integrated Circuit Solution for Active Antennas (FM, DAB, DVB-T, ISDB-T)	QFN16



Atmel Corporation 1600 Technology Drive, San Jose, CA 95110 USA **T:** (+1)(408) 441.0311 **F:** (+1)(408) 436.4200 | **www.atmel.com**

© 2013 Atmel Corporation. All rights reserved. / Rev.: Atmel-4622K-AutoSolutionsBrochure_E_A4_0213

Atmel®, Atmel logo and combinations thereof, and others are registered trademarks or trademarks of Atmel Corporation or its subsidiaries. Other terms and product names may be trademarks of others.

Disclaimer: The information in this document is provided in connection with Atmel products. No license, express or implied, by estoppel or otherwise, to any intellectual property right is granted by this document or in connection with the sale of Atmel products. EXCEPT AS SET FORTH IN THE ATMEL TERMS AND CONDITIONS OF SALES LOCATED ON THE ATMEL WEBSITE, ATMEL ASSUMES NO LIABILITY WHATSOEVER AND DISCLAIMS ANY EXPRESS, IMPLIED OR STATUTORY WARRANTY RELATING TO ITS PRODUCTS INCLUDING, BUT NOT LIMITED TO, THE IMPLIED WARRANTY OF MERCHANTABILITY, FITNESS FOR A PARTICULAR PURPOSE, OR NON-INFRINGEMENT. IN NO EVENT SHALL ATMEL BE LIABLE FOR ANY DIRECT, INDIRECT, CONSEQUENTIAL, PUNITIVE, SPECIAL OR INCIDENTAL DAMAGES (INCLUDING, WITHOUT LIMITATION, DAMAGES FOR LOSS AND PROFITS, BUSINESS INTERRUPTION, OR LOSS OF INFORMATION) ARISING OUT OF THE USE OR INABILITY TO USE THIS DOCUMENT, EVEN IF ATMEL HAS BEEN ADVISED OF THE POSSIBILITY OF SUCH DAMAGES. Atmel makes no representations or warranties with respect to the accuracy or completeness of the contents of this document and reserves the right to make changes to specifications and products descriptions at any time without notice. Atmel does not make any commitment to update the information contained herein. Unless specifically provided otherwise, Atmel products are not suitable for, and shall not be used in, automotive applications. Atmel products are not intended, authorized, or warranted for use as components in applications intended to support or sustain life.