

## ***i*Coupler<sup>®</sup> Isolation in RS-232 Applications**

by Sean Clark and Ronn Kliger

### **INTRODUCTION**

The RS-232 bus standard is one of the most popular serial communication bus designs. RS-232 was originally specified by the Electronics Industry Association (EIA) in 1962 to communicate between computing equipment and modems. The RS-232 standard is still widely used as an intersystem serial communication link.

The RS-232 standard is a serial data, point-to-point design, with a signal line dedicated for communication in each direction. These two dedicated unidirectional lines result in full-duplex communication.

Although no maximum cable length is specified, maximum practical cable length is approximately 16 meters. The RS-232's simplicity and flexibility coupled with its long legacy contribute to its continued popularity for intersystem connections.

Because the RS-232 standard is typically used as an intersystem connection, isolation between the bus and each system connected is critical. Digital isolation provides crucial isolation and protection from overvoltage transients between the RS-232 cable bus and the systems connected to it. Digital isolation also eliminates ground loops on the RS-232 bus. Digitally isolating the RS-232 bus from the systems connected to the bus reduces signal distortion and errors, and provides system and component protection from system and bus voltage and ground mismatches.

The intention of this application note is to give the user a brief overview of the RS-232 bus physical layer, as well as an understanding of why isolation is so important to the system. This application note details how to implement isolation for a RS-232 bus using Analog Devices' *i*Coupler products.

### **RS-232 OVERVIEW**

RS-232 is more properly known as EIA232, but is commonly referred to by the older "Recommended Standard" 232 designation. RS-232 uses single-ended (unbalanced) point-to-point signaling, with signals referenced to ground.

RS-232 specifies a maximum data rate of 20 kbps. The TIA/EIA562 standard, a low voltage version of RS-232, is specified to operate to 64 kbps.

The RS-232 specification does not define a maximum cable length. However, RS-232 specifies a maximum line capacitance of 2,500 pF, and a load impedance of 3 k $\Omega$  to 7 k $\Omega$ . These specifications result in a typical maximum usable cable length of approximately 16 meters.

The standard specifies driver output levels as  $-5$  V to  $-15$  V for a Logic 1 and  $+5$  V to  $+15$  V for Logic 0. Receivers are specified to read input levels of  $-3$  V to  $-15$  V as a Logic 1, and levels of  $+3$  V to  $+15$  V as a Logic 0. Voltage levels between  $-3$  V and  $+3$  V are undefined. This wide voltage swing and center undefined voltage region ensure a high level of noise immunity, and allow valid signal levels to be received at maximum cable lengths.

The RS-232 standard has been revised several times since its introduction. Letter designations denote the various revisions. The RS-232C is the revision commonly used by the PC industry. The fourth revision, RS-232D, added three additional test lines and defined the maximum line capacitance of 2,500 pf.

As of this writing, the most recent revision is EIA232E, introduced in 1991. This revision officially changed the name designation to EIA232. Additionally, some signal lines were renamed and a protective ground conductor was defined.

The RS-232 specification defines the physical layer only. Signal protocol is defined by the user, or standards that define the protocol and specify RS-232 for the physical layer.

The RS-232 specification defines the pinout for a 25-pin D connector with 20 signal lines. However, a 9-pin connector, 8-signal configuration as defined by EIA574 is more commonly used.

Only one line in each direction is for data transmission in the RS-232 system. All other lines are designated for signal communications protocol. These signal lines give the designer multiple options for configuring the RS-232 protocol. The system can be designed for asynchronous operation utilizing the 8 signals in the commonly used 9-pin connector. At its simplest, RS-232 can be implemented using just three lines: Tx (data), Rx (data), and GND.

The 25-pin connector specified in the RS-232 standard defines 11 signals not used in the 9-pin connector. These additional signals include a clock line for each data direction to allow the use of synchronous data protocols.

Of particular interest in this application note discussion is the inclusion of the protective ground line in the 25-pin connection. This line is designed as an equipment safety ground, and is typically connected to power ground of the serial adapter or chassis ground. This ground should not be connected to the signal ground. Furthermore, it is not recommended that this ground be connected between the two systems, particularly in long cable line applications. Connection of these grounds together, or to both systems, can create ground loops.

## RS-232 PIN CONNECTIONS

The RS-232 standard divides equipment connected to the serial port into two categories. These are DCE (data communications equipment) and DTE (data terminal equipment). These designations are a legacy of the computer and modem heritage of the standard, which defined data terminal equipment as the computer or computer terminal, and data communications equipment as the modem. In practical application terms, the DCE and DTE designations define which lines are connected to each system as inputs and which lines are outputs.

Although the RS-232 specification does not define a signal protocol, a typical implementation uses asynchronous signaling utilizing eight signal lines and a ground (Figure 1).

As mentioned above, systems can be configured using less than all six of the handshaking signal lines. Although the hardware may run with just Tx, Rx, and ground connected, some driver software will continue to wait for one of the handshaking lines to go to the correct level. Depending on the signal state, this may or may not work.

For reliability, the unused handshake signals should be looped back and connected to the request to send (RTS) signal. When the lines are handshake-looped, the RTS output from the processor or controller immediately activates the clear to send (CTS) input. In this configuration, the transmitting system effectively controls its own handshaking. Alternatively, some of these signals, such as the data terminal ready (DTR), can be hardwired to a valid signal level, effectively signaling that the system is always ready to receive data.

For a more detailed explanation of connections using the RS-232 protocol, see the AN-375 Application Note at [http://www.analog.com/UploadedFiles/Application\\_Notes/527881158649405705232480454AN375.pdf](http://www.analog.com/UploadedFiles/Application_Notes/527881158649405705232480454AN375.pdf).

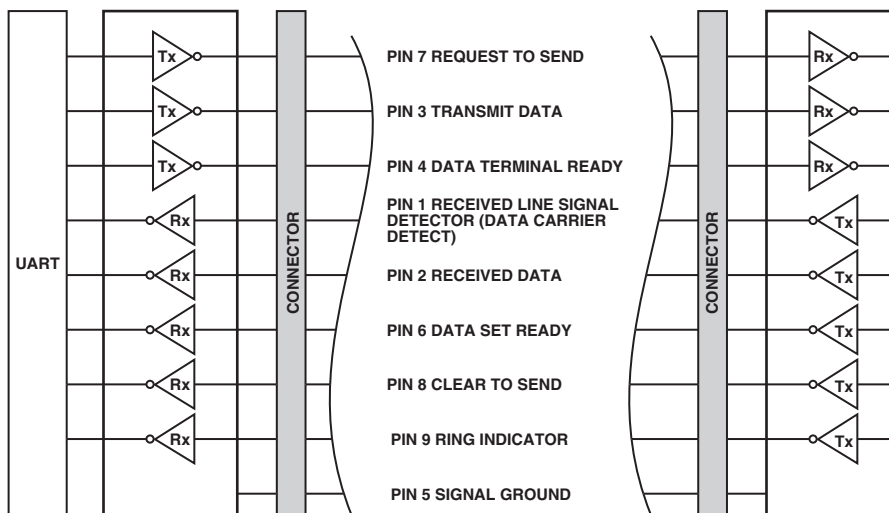

Figure 1. RS-232 8-Signal Network Configuration

## SYSTEM ISOLATION OVERVIEW

Unwanted currents and voltages on a cable bus connecting two systems have the potential to cause severe problems. High voltages and currents can destroy components connected to the bus. These unwanted voltages and currents come primarily from two sources: ground loops and electrical line surges.

Ground loops occur when a bus or system utilizes multiple ground paths. It cannot be assumed that two system grounds connected to the bus and separated by several meters or more will be at the same potential. Because these grounds are unlikely to be at the same potential, current will flow between these points, and this unintended current flow can damage or destroy components.

Electrical surges can be caused by many sources. These surges are the result of currents coupled onto cable lines through induction. Long cable lines and systems in industrial environments are especially susceptible to this phenomenon. The operation of equipment switching large currents, such as electric motors, causes rapid changes in the ground potential. These changes can generate a current flow through any nearby lines to equalize the ground potential. Other induction surge sources include electrostatic discharge (ESD) and lightning strikes. These induced surges can result in hundreds or even thousands of volts of potential on the line, and manifest themselves as transient current and voltage surges.

Thus, the cable end node may receive a switching signal superimposed on a high voltage level with respect to its local ground. These uncontrolled voltages and currents can corrupt the signal, and can be catastrophic to the device and system, causing damage or destruction of the components connected to the bus, and resulting in system failure. Because RS-232 systems run over cables of up to 16 meters and interconnect two systems, they are susceptible to these events.

To protect against this potentially destructive energy, all devices on the bus and the systems connected to the bus must be referenced to only one ground. Isolating the RS-232 system devices from each of the systems connected to the bus prevents ground loops and electrical surges from destroying circuits.

Isolation prevents ground loops because the systems connected to RS-232 cable bus, and each RS-232 circuit, has a separate and isolated ground. By referencing each RS-232 circuit only to one ground, ground loops are eliminated.

Isolation also allows the RS-232 circuit reference voltage levels to rise and fall with any surges that appear on the cable line. Allowing the circuit voltage reference to move with surges, rather than being clamped to a fixed ground, prevents devices from being damaged or destroyed.

To accomplish system isolation, both the RS-232 signal lines and power supplies must be isolated. Power isolation is obtained through the use of an isolated dc to dc power supply. Signal isolation is typically accomplished with optocouplers, or with Analog Devices' innovative *iCouplers*.

## ISOLATION IMPLEMENTATION

The implementation of isolation is not overly complex. However, the designer must consider several important factors when implementing the isolation circuitry.

Because digital isolators do not support the RS-232 signal standard, it is not possible to insert a digital isolator between the RS-232 transceivers and the RS-232 cable. Theoretically, transformers could be used to supply isolation at that location. However, the very slow speeds of the bus would require large transformers, making this solution impractical.

RS-232 signal path isolation is accomplished by designing isolators into the digital signal path between the RS-232 transceiver and the local system. The system side RS-232 transceivers utilize digital logic level signals of 0 V to 5 V or 0 V to 3 V, and typically connect to a universal asynchronous receiver/transmitter (UART) or processor. The *iCoupler* isolator contains input and output circuits that are electrically isolated from one another. Placing an *iCoupler* in this location electrically isolates the RS-232 cable bus signals from each system connected to it.

To complete the isolation of the RS-232 circuits from the local system, a dc to dc isolated power converter is required. The isolated power supply is used to supply power to the local RS-232 transceiver and RS-232 side of the isolator. The isolated power supply is typically supplied from the local system.

The combination of digital isolators and an isolated dc to dc power supply creates an effective protection against surge damage, and eliminates ground loops. Figures 2 and 3 illustrate system isolation design in typical RS-232 signal configurations using *iCoupler* integration.

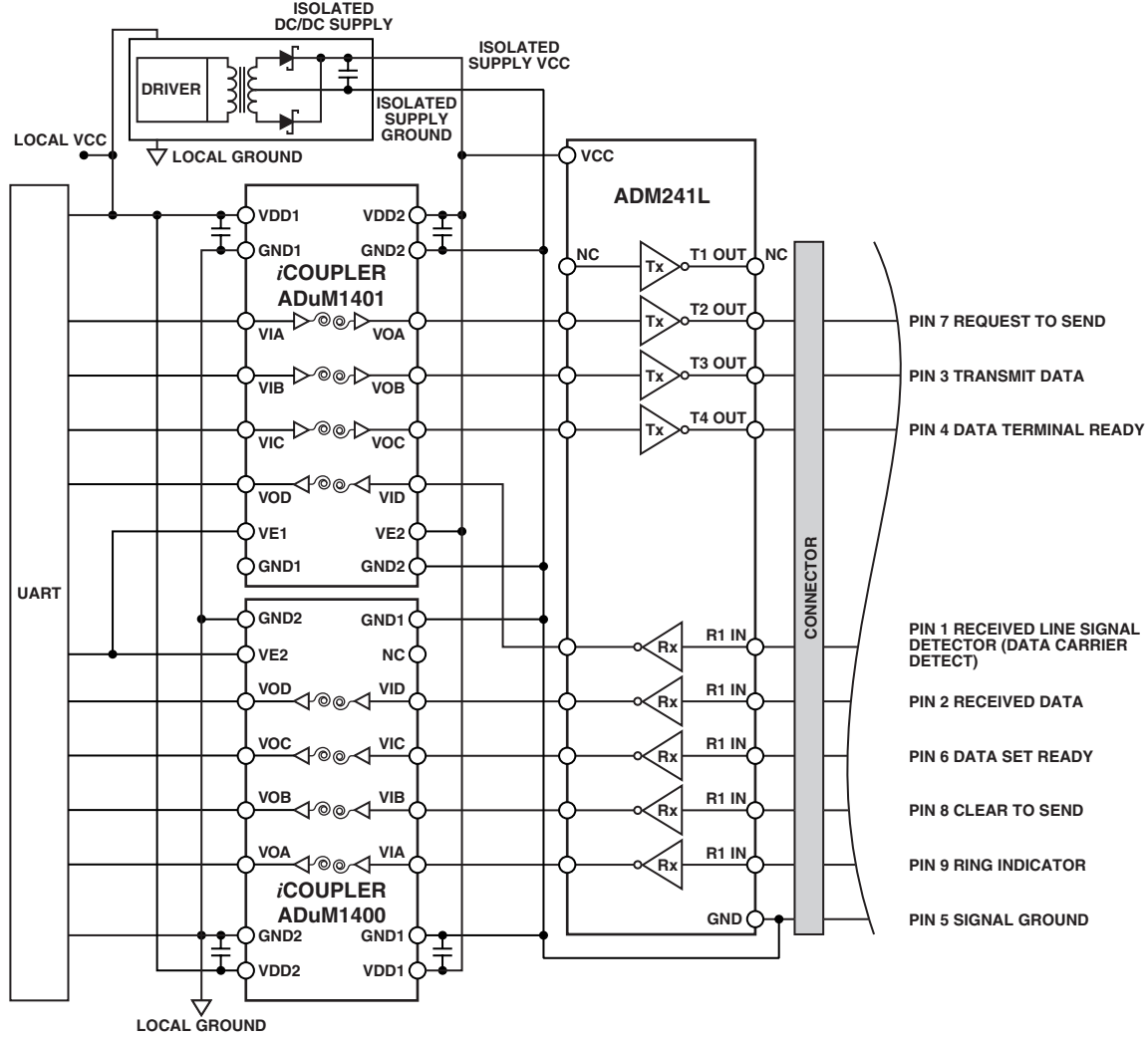

Figure 2. Isolated RS-232 8-signal circuit (DTE side illustrated). The iCoupler signal isolator is placed between the system UART and the RS-232 transceiver. The system uses an isolated dc supply to power the RS-232 transceiver and the transceiver side of the iCoupler. Note that Tx1 of the ADM241L RS-232 transceiver is not used in the 8-signal configuration.

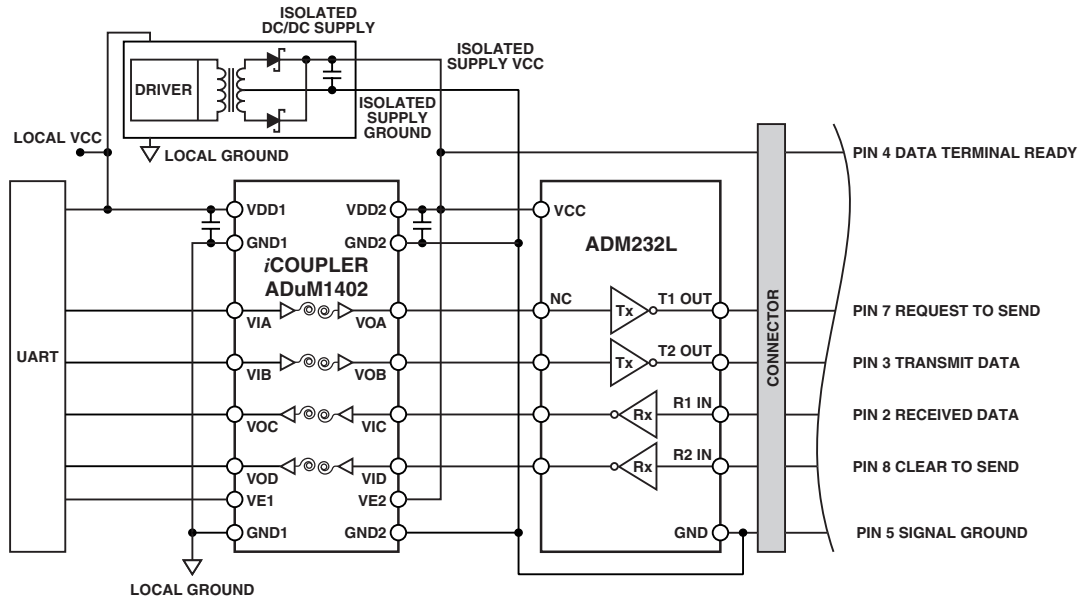

Figure 3. Isolated RS-232 5-signal circuit (DTE side illustrated). This design minimizes the signals used in the RS-232 bus. The iCoupler signal isolator is placed between the system UART and the RS-232 transceiver. The system uses an isolated dc supply to power the RS-232 transceiver and the transceiver side of the iCoupler.

### ISOLATION DEVICE SELECTION

System performance requirements will have the most impact on the selection of an isolation device. Other considerations include space constraints and cost.

### DATA RATE REQUIREMENTS

System data rate requirements are likely to be the single most important parameter for device selection.

Although the RS-232 specification defines data rates to 20 kbps, many newer RS-232 transceivers have the capability to run at much higher data rates. These include low voltage RS-232 transceivers that are compatible with the newer TIA/EIA562 low voltage version of RS-232. As noted, this specification defines operation to 64 kbps. Some low voltage RS-232 transceivers have the capability to operate at even higher data speeds. The ADM3312E specifies a data rate of 460 kbps. These higher data rates extend the usability of the RS-232 specification, and give system designers numerous options.

The use of high data rates in a system will narrow the selection of possible isolation devices to the high performance products available. Fortunately, all iCoupler products operate up to data rates of 1 Mbps. The iCoupler products portfolio also includes devices that operate up to data rates of 25 Mbps and 100 Mbps.

Device cost typically rises in proportion to data rate performance. Therefore, a designer should take care not to specify a device with more performance than is required. However, low performance device selection can make future system performance upgrades more costly and involved, because all devices not compatible with upgraded system data speeds will require replacement.

### SPACE REQUIREMENTS

Space constraints are a second area of concern that can also limit a designer's choices. Maximum dimension requirements are a concern for virtually all applications. However, some implementations can be severely space limited. Fortunately, there are now solutions for these situations.

Solutions for systems where space is an issue include the combination of one ADuM1401 iCoupler and one ADuM1400 iCoupler for isolation of an 8-signal RS-232 network (see Figure 2). The ADuM140x are 4-channel isolation devices in a 16-lead SOIC package; each device takes the place of four optocouplers and associated circuitry.

### COST REQUIREMENTS

Cost constraints and concerns are a reality in virtually all system design work. Cost considerations can have an affect on the design choices for a system. As noted above, isolator device cost rises in proportion with data rate performance. Specifying a device with only the system performance required can reduce costs.

Other cost issues include a consideration of the number of devices used. The iCoupler device cost increases with channel count. However, the cost per channel decreases as the device channel count increases.

Additional cost benefits of integrating as many channels into one device as possible include reduction in board space and assembly costs. A lower device count results in smaller boards. Also, lower device count typically results in a less complex board layout. The combination of smaller boards and less complex layout reduces board costs. In addition, circuit board assembly costs typi-

cally decrease proportionally as the number of devices required for the board assembly process decreases. Therefore, designing with fewer devices results in lower manufacturing costs.

## ANALOG DEVICES' *i*COUPLER PRODUCTS

Analog Devices' *i*Coupler device technology has enabled products that possess distinct advantages for the system designer in comparison to other available isolation options.

The unique *i*Coupler technology results in a new option for implementing isolation. The *i*Coupler products provide superior performance, lower power consumption, higher reliability, and lower component count, with cost characteristics that are comparable with optocouplers.

## *i*COUPLER TECHNOLOGY OVERVIEW

ADI's *i*Coupler technology provides isolation based on-chip scale transformers rather than the LEDs and photodiodes used in optocouplers. By fabricating the transformers directly on-chip using wafer level processing, *i*Coupler channels can be integrated with each other and other semiconductor functions at low cost (see Figure 4).

The technology used in *i*Coupler design eliminates the inefficient electro-optical conversions that take place in optocouplers. This is because *i*Couplers eliminate the LEDs used in optocouplers. Also, because channels are fabricated entirely with wafer level processing, multiple *i*Coupler channels can be easily integrated within a single package. *i*Coupler technology provides increased performance, reduced power consumption, smaller size, increased reliability, and cost benefits.

Another distinct advantage of *i*Couplers over optocouplers is the elimination of external components. In

addition to bypass capacitors, optocouplers require external discrete devices to bias the output transistors and drive the LEDs. *i*Coupler devices require no external components other than decoupling capacitors. The *i*Coupler solution results in less circuit complexity and lower cost.

The *i*Coupler products also incorporate unique refresh and watchdog circuits. In the absence of logic transitions at the input for more than 2  $\mu$ s, a periodic set of refresh pulses indicative of the correct input state is generated to ensure dc correctness at the output. If the *i*Coupler output side circuit receives no internal pulses for more than about 5  $\mu$ s, the input side circuit is assumed to be unpowered or nonfunctional, in which case the isolator output is forced to a default state by the watchdog timer.

## *i*COUPLER PRODUCT SELECTION

The *i*Coupler family comprises a broad portfolio of products, allowing the system designer to select a product ideally suited for the design. The *i*Coupler device portfolio has 1-channel through 4-channel options and include devices designed for bidirectional communication and enhancing flow through board design. *i*Coupler devices are also available for a range of data rate performances, allowing the designer to select the perfect product for the application.

ADI's *i*Coupler portfolio of features and options allows the design of a system with fewer devices, and a better match for the system data performance requirements (see Table 1).

As noted, ADI offers a wide selection of *i*Coupler products. The combination of performance and channel configuration allows the system designer options for optimizing system and device match. Table 1 shows a comparison of product options, including the number of channels as well as data speed performance.

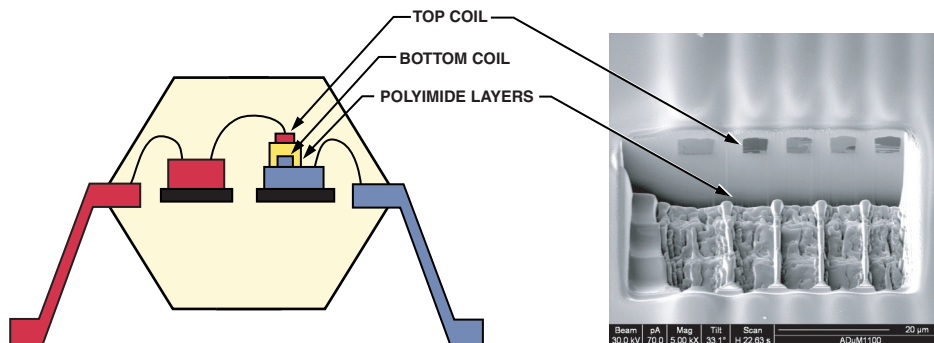

Figure 4. Cross Section of *i*Coupler Configuration



## BYPASS CAPACITORS

The *iCoupler* products need no external components other than bypass capacitors. A bypass capacitor is strongly recommended for the input and output supply pins. The bypass capacitor value should be between 0.01  $\mu$ F and 0.1  $\mu$ F. The total lead length between both ends of the capacitor and the power supply pins should not exceed 20 mm.

## OUTPUT ENABLE CONTROL

Many of the *iCoupler* products have output enable control pins to allow outputs to be placed into a high impedance state. The outputs are in an active logic state when the output enable pins are high or floating. The outputs are disabled when the output enable pin is low. It is recommended that the output enable pins be pulled to a known logic level, either high or low, in noisy applications.

## SUMMARY

The flexibility and high noise immunity of the RS-232 specification make this design very popular for intersystem communication. However, intersystem communication cable systems are highly susceptible to interference or damage from overvoltage transients and ground loops.

Digitally isolating the RS-232 bus from the systems connected to the bus reduces signal distortion and errors, and provides system and component protection from system and bus voltage and ground mismatches.

Analog Devices' *iCoupler* family of products covers a broad range of performance, channel counts, and configurations. The combination of performance and channel configuration give the system designer multiple options, allowing system design optimization. The *iCoupler* products provide a cost effective method for including critical isolation into a system design.

**Table 1. *iCoupler* and Isolated RS-485 Transceiver Products**

Product	Model	Number of Channels	Channel Configuration*	UL Insulation Rating (kV)	Max Data Rate, 5 V (Mbps)	Max Prop. Delay, 5 V (ns)	Max Operating Temp. (°C)	Package
ADuM1100	ADuM1100AR	1	1/0	2.5	25	18	105	8-Lead Narrow Body SOIC
	ADuM1100BR	1	1/0	2.5	100	18	105	8-Lead Narrow Body SOIC
	ADuM1100UR	1	1/0	2.5	100	18	125	8-Lead Narrow Body SOIC
ADuM120x	ADuM1200AR	2	2/0	2.5	1	150	105	8-Lead Narrow Body SOIC
	ADuM1200BR	2	2/0	2.5	10	50	105	8-Lead Narrow Body SOIC
	ADuM1200CR	2	2/0	2.5	25	45	105	8-Lead Narrow Body SOIC
	ADuM1201AR	2	1/1	2.5	1	150	105	8-Lead Narrow Body SOIC
	ADuM1201BR	2	1/1	2.5	10	50	105	8-Lead Narrow Body SOIC
	ADuM1201CR	2	1/1	2.5	25	45	105	8-Lead Narrow Body SOIC
ADuM130x	ADuM1300ARW	3	3/0	2.5	1	100	105	16-Lead Wide Body SOIC
	ADuM1300BRW	3	3/0	2.5	10	50	105	16-Lead Wide Body SOIC
	ADuM1300CRW	3	3/0	2.5	90	32	105	16-Lead Wide Body SOIC
	ADuM1301ARW	3	2/1	2.5	1	100	105	16-Lead Wide Body SOIC
	ADuM1301BRW	3	2/1	2.5	10	50	105	16-Lead Wide Body SOIC
	ADuM1301CRW	3	2/1	2.5	90	32	105	16-Lead Wide Body SOIC
ADuM140x	ADuM1400ARW	4	4/0	2.5	1	100	105	16-Lead Wide Body SOIC
	ADuM1400BRW	4	4/0	2.5	10	50	105	16-Lead Wide Body SOIC
	ADuM1400CRW	4	4/0	2.5	90	32	105	16-Lead Wide Body SOIC
	ADuM1401ARW	4	3/1	2.5	1	100	105	16-Lead Wide Body SOIC
	ADuM1401BRW	4	3/1	2.5	10	50	105	16-Lead Wide Body SOIC
	ADuM1401CRW	4	3/1	2.5	90	32	105	16-Lead Wide Body SOIC
	ADuM1402ARW	4	2/2	2.5	1	100	105	16-Lead Wide Body SOIC
	ADuM1402BRW	4	2/2	2.5	10	50	105	16-Lead Wide Body SOIC
ADuM1402CRW	4	2/2	2.5	90	32	105	16-Lead Wide Body SOIC	

\*Channel configuration refers to the directionality of the isolation channels. For example, 2/1 means two channels communicate in one direction while the third channel communicates in the reverse direction.

