

## Using the AD9709, AD9763, AD9765, AD9767 Dual DAC Evaluation Board

By Steve Reine and Dawn Ostenberg

### GENERAL DESCRIPTION

The AD9709, AD9763, AD9765 and AD9767 are high-speed, high-performance dual DACs (8-, 10-, 12-, 14-bits) designed for I/Q transmit applications and for applications where board space is at a premium. The evaluation board allows the user to take full advantage of the various modes in which the AD976x can operate. This includes operation as dual DACs with their own individual digital inputs, as well as interleaved DACs where data is alternately written from digital input Port 1 to either of the two DACs. Information on how to operate the evaluation board is included in this application note. However, for more detailed performance information, the reader should consult the individual data sheets for the AD9709, AD9763, AD9765, and AD9767.

The 8-, 10-, 12-, and 14-bit DACs in this family are all pin-for-pin-compatible and are MSB justified. Therefore, the same evaluation board can be used to evaluate all four parts.

### EVALUATION SETUP

To evaluate the performance of the AD976x dual DAC family, a small set of measurement and signal generation equipment is needed. Figure 1 shows a typical test setup. Power supplies capable of driving from 3 V to 5 V are needed for both analog and digital circuitry on the evaluation board. A signal generator and digital word generator are needed to provide the data and clock inputs. On the output, an oscilloscope or spectrum analyzer may be needed, depending on the type of performance being analyzed.

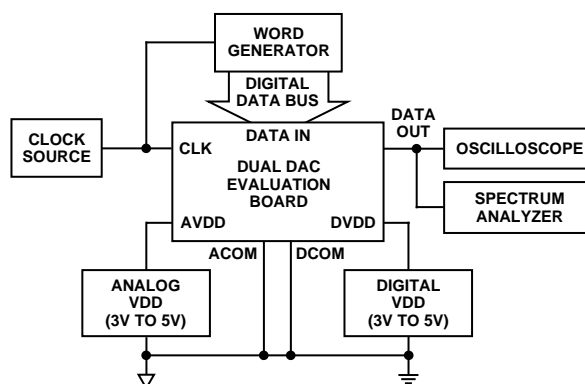

Figure 1. Typical Test Setup to Evaluate Performance of AD976x Dual DAC Using Evaluation Board

### POWER CONNECTIONS

The AD9709, AD9763, AD9765, AD9767 dual DACs all have separate digital and analog power and ground pins. Analog and digital power and ground have their own banana-style connectors on the dual DAC evaluation board. The best performance when using the evaluation board is achieved when analog and digital power and ground are connected to separate power supplies.

Figure 2 shows the power supply, grounding, and decoupling connections for the evaluation board and for the DAC itself. Note that for best noise rejection on the power supplies, the high value bulk capacitors are placed at the external power connectors, while the smaller value capacitors, needed for high frequency rejection, are located close to the DAC.

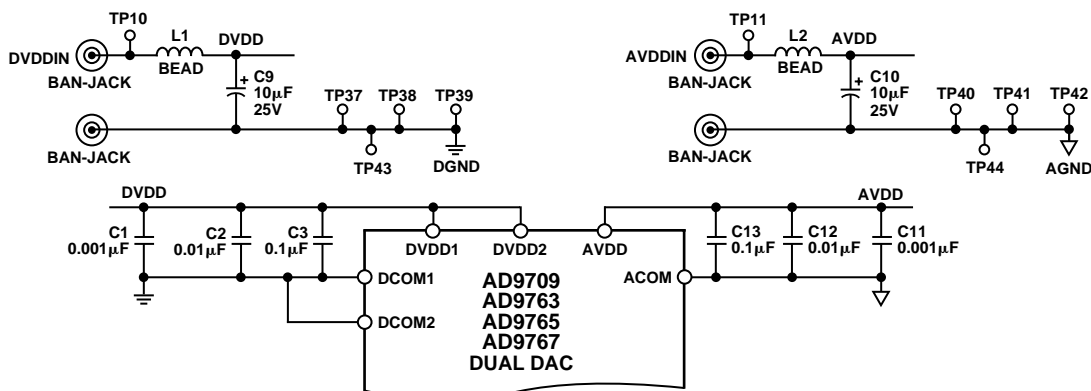

Figure 2. Analog and Digital Power Connections on Dual DAC Evaluation Board

Analog and digital supplies can be run at either 3 V or 5 V, and do not have to run from the same supply voltage. Regardless of supply voltage, the digital input data can be safely run from 3 V or 5 V logic levels, as long as the proper resistor packs are placed in the digital input data path (see Digital Inputs section).

## DIGITAL INPUTS

The digital inputs on the dual DAC evaluation board are designed to accept inputs from any generic word generator. However, when running the DAC at high sample rates, the quality of the digital data can have an impact on the performance of the DAC. As an example, if the edges of the digital information are slow, or the edges of the various bits are skewed from each other in time, specifications such as SNR and SINAD may be degraded.

The digital input path on the evaluation board includes both pull-up and pull-down plug-in resistor packs. The pull down resistors allow the user to apply digital logic at 5 V levels when the DAC digital supply is operating at 3 V, and the pull-ups allow 3 V logic levels when the DAC is run from a 5 V digital supply. The digital input signal path is shown in Figure 3.

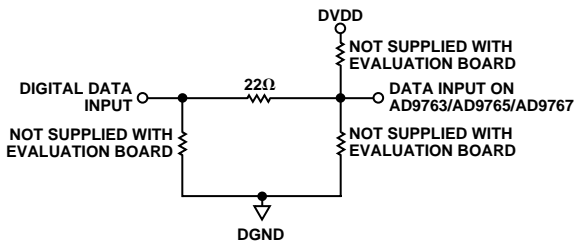

Figure 3. Input Structure of Digital Input Signal Path on Dual DAC Evaluation Board

## CLOCK INPUTS

SMA connectors S1 to S4 are intended to be used as clock and control lines for the AD976x, and are 50 Ω terminated. The selection of JP9 also allows the user to select a clock generated on the same digital data bus as the input data.

Jumpers JP1 to JP7, JP9, and JP16 control the clock inputs for the various clock modes in which the dual DACs can operate. It is recommended that the clock source be a square wave with minimal overshoot and undershoot. Overshoot and undershoot beyond the supply rails can inject noise onto the clock, which may result in jitter and reduced DAC performance. The dual DACs can operate with a sine wave clock, but dynamic performance will be degraded. Figure 4 shows the clock input section and jumper options for the dual DAC evaluation board.

## MODES OF OPERATION

The AD976x dual DAC family is designed to operate either as two completely separate DACs in dual DAC mode, or with a single digital input port in which the input data is alternately sent to either of the two DACs (interleaving mode).

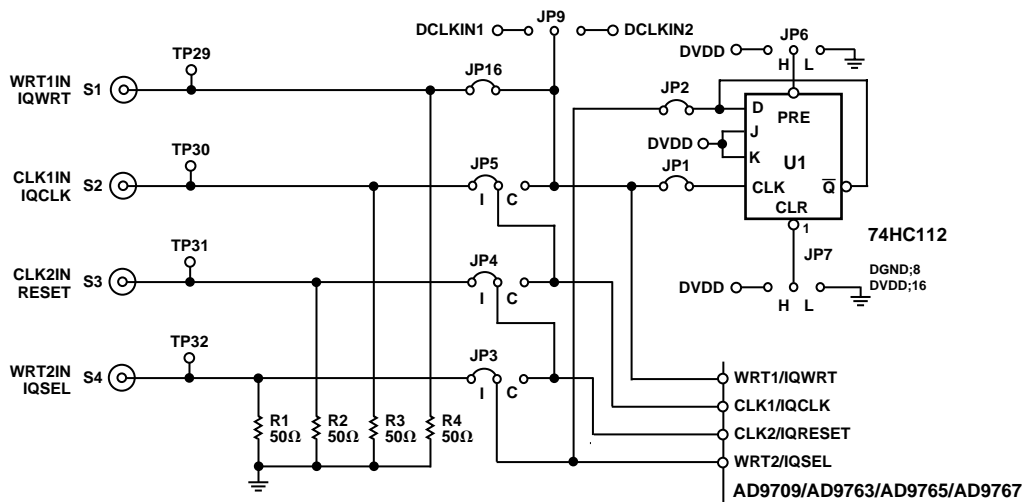

Figure 4. Jumper Options for Clock Input Section on Dual DAC Evaluation Board

## DUAL DAC MODE

Jumper J8 controls the logic level of the MODE pin on the AD976x dual DAC. With this jumper in the D position, the mode pin is pulled to a high logic level and the AD976x is in dual DAC mode.

The simplest method for operating the dual DAC evaluation board in the dual DAC mode is to select a common clock for WRT1, WRT2, CLK1, and CLK2. An external clock generator can be selected by inserting JP16, or a clock from the word generator can be selected by inserting JP9. By inserting JP3, JP4, and JP5 all in the C position, the selected clock can be applied to all four clock inputs.

Different combinations of JP3, JP4, and JP5 allow multiple options if the user desires to drive the WRT and CLK inputs from separate clocks.

In the dual mode, jumpers JP1 and JP2 should be removed. The state of Jumpers JP6 and JP7 does not matter in this mode.

Table I illustrates the jumper positions required to operate in the dual DAC mode of operation.

**Table I. Jumper Options for Dual DAC Mode**

Jumper	Position	Description
JP1, JP2, JP6, JP7	Removed	These are only used in interleaved mode.
JP3, JP4, JP5	C	With these in the B position, the evaluation board can be run with one common clock.
JP8	D	Enables Dual DAC Mode.
JP9	Optional	Selects clock from word generator. Remove JP9 if clock source is from S1/JP16.
JP16	Optional	Selects clock from connector S1. Remove JP16 if clock source is from JP9/JP16/DCLK1, DCLK2.

## INTERLEAVING MODE

With jumper JP8 in the I position, the MODE pin on the AD976x is pulled to a logic low level and the DAC is in interleaving mode. In this mode, a single stream of digital data drives Port 1 on the DAC. This stream of data contains alternating bits from two data channels. By using the correct clock and control signals, data in the two channels will be separated and sent to the correct DAC outputs. This is typical of an I/Q application.

In interleaving mode, the definitions for the four clock inputs change. WRT1, WRT2, CLK1, and CLK2 become IQWRT, IQCLK, IQRESET, and IQSEL, respectively. For

detailed information on the functions of these inputs, as well as the DAC input and output timing, see the AD9709, AD9763, AD9765, and AD9767 data sheets.

Operation with a single clock can be achieved by selecting JP16 or JP9 for the clock source and inserting JP5 in the C position, and removing JP3. JP4 can be used to control IQRESET, but for most evaluations can simply be tied low (Position I).

In interleaving mode, digital data present at input Port 1 is written into the Port 1 or Port 2 input buffers internal to the DAC on the rising edge of IQWRT. The port into which data is written depends on the state of IQSEL at the time of the IQWRT rising edge. If IQSEL is high when the rising edge occurs, data will be written to input Port 1. If IQSEL is low at that time, data will be written to input Port 2.

U1 on the evaluation board provides an alternating IQSEL signal by toggling on every falling edge of IQWRT. To enable this function, insert JP1 and JP2 and remove JP3. JP6 and JP7 are used to synchronize the input data stream with the IQSEL pin. To perform this synchronization, power up the evaluation board with the IQWRT and input data clocks disabled and at logic low. If the first word in the digital data stream is meant for Channel 1, preset U1 by inserting JP7 in the H position, temporarily insert JP6 in the L position, then permanently in the H position. If the first word in the data stream is intended for Channel 2, reset U1 by inserting JP6 in the H position, insert JP7 temporarily in the L position, then permanently in the H position.

Table II illustrates the jumper positions required to operate in the dual DAC mode of operation.

**Table II. Jumper Options for Interleaved Mode**

Jumper	Position	Description
JP1, JP2	Inserted	These enable U1 to generate the alternating logic signal for IQSEL.
JP3	Remove	If the IQSEL logic is to be generated by U1, this is not needed.
JP4	I	Use to allow S3 control of IQRESET pin.
JP5	C	Allows IQWRT and IQCLK to be driven by a common clock.
JP6, JP7		These are used to preset the IQSEL pin before the data clock is enabled. See text for description of use.
JP8	I	Enables Interleaved Mode.
JP9	Optional	Selects clock from word generator. Remove JP9 if clock source is from S1/JP16.
JP16	Optional	Selects clock from Connector S1. Remove JP16 if clock source is from JP9/DCLK1, DCLK2.

## CLOCK TIMING/PERFORMANCE

To ensure that specified setup-and-hold times are met, the digital data inputs should change state on the falling edge of the clock. However, due to timing skews and delays inherent in some circuits, this does not always happen. If the timing of the data transition and the rising edge of the clock violates the setup-and-hold times, SNR performance will be seriously degraded. Figure 5 shows the valid window during the clock cycle in which the digital input data can transition with no degradation in SNR performance.

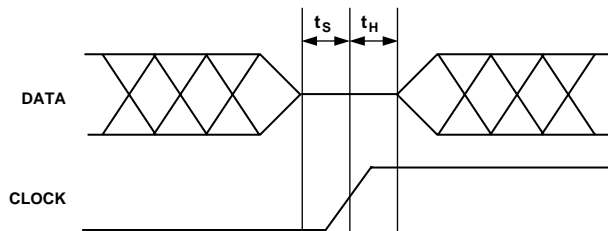

Figure 5. Valid Window for Data Transition During Clock Cycle

Correct timing can be verified by generating a word pattern that repeatedly toggles the LSBs between Logic 1 and Logic 0. The user will also need a digital oscilloscope with persistence capability.

Place one probe from the scope on the clock input of the DAC. The sensitivity of this measurement is in the tenths of nanoseconds, so the probe should be placed as close as possible to the DAC itself. In addition, the scope should be set to trigger from this channel. Place a second probe from the oscilloscope on the LSB input of the DAC, again as close as possible to the DAC itself. The barrels of both probes should be grounded to the evaluation board, as close to the measurement point as possible. A convenient way of doing this is to wrap a piece of bus wire around the barrel and then solder the other end of the bus wire to the PCB. Figure 6 illustrates a typical oscilloscope display for this test, as well as the proper way to use the scope probes.

For the most accurate results, identical high input impedance, low input capacitance probes should be used. If possible, they should also be calibrated.

The data setup time can be measured by placing a variable delay between the clock generator and the clock input of the word generator. This is most often done by using a pulse generator. By adjusting the delay of the digital data, place the data transition point on the falling edge of the clock. At this point, SNR should be optimized. Increase the amount of delay for the digital data, moving the transition point closer to the rising edge. As the data transition gets close to the rising edge, SNR will begin to degrade. At this point, on the oscilloscope, measure the time difference between the data transition and the midpoint of the rising edge. This is the measured data setup time.

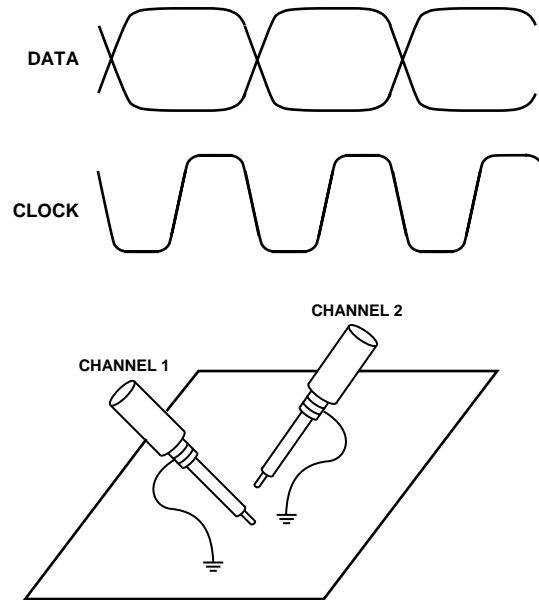

Figure 6. Verifying Clock/Data Timing on Evaluation Board, Proper Use of Scope Probes

To measure the input data hold time, perform the same operation, but start with the data transition occurring at the midpoint of the clock transition. SNR at this point will be completely degraded. Increase the digital input delay until the SNR is optimized. At this point, again measure the time difference between the data transition and the midpoint of the rising edge. This is the measured data hold time.

## REFERENCE OPERATION

The AD9709, AD9763, AD9765, AD9767 contain a single 1.2 V reference that is shared by both of the DACs on the chip. This reference drives two control amplifiers that independently control the full-scale output currents in each of the two DACs. Using the 1.2 V reference and the control amplifier, reference currents are produced for each DAC in an external resistor attached to FSADJ1 (DAC1) and to FSADJ2 (DAC2). The relationship between the external resistor current and the full-scale output current is:

$$I_{OUTFS} = 32 \times \text{Reference Current}$$

Using the internal reference, this can also be expressed as:

$$I_{OUTFS} = 38.4 \div R_{EXT}$$

On the evaluation board, R9 and R10 are the two external resistors that define the full-scale current.

An external reference can also be used simply by driving the REFIO pin on the dual DAC (TP36) with an external reference. The input impedance of the REFIO pin is very high, minimizing any loading of the external reference. However, because some references behave poorly when driving capacitive loads, the bypass capacitor on

REFIO (C14) may need to be removed under these conditions. Figures 7 and 8 show the internal and external reference configurations for the AD9709, AD9763, AD9765, and AD9767.

When using an external reference in this way, the full-scale output current for each DAC can be defined by;

$$I_{OUTFS} = 32 \times V_{REF}/R_{EXT}$$

Note that in the internal reference configuration, any additional load on the reference should be buffered with an external amplifier. This external amplifier is not included on the evaluation board.

For more detailed information on the operation of the reference section of the DACs, see page 9 of the data sheet.

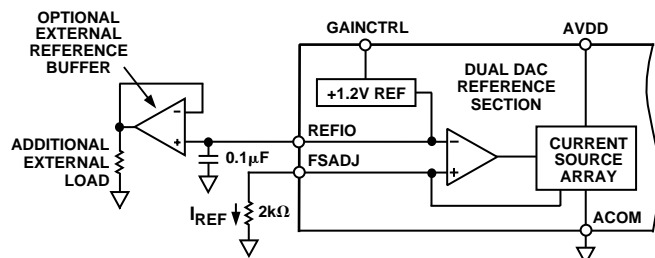

Figure 7. Internal Reference Configuration

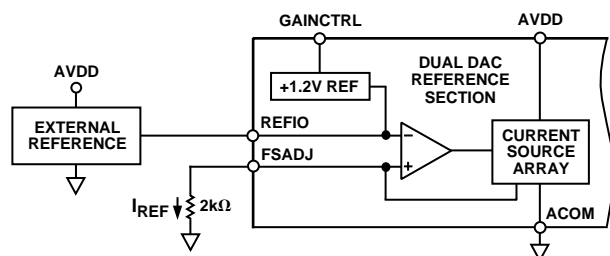

Figure 8. External Reference Configuration

#### MASTER/SLAVE RESISTOR MODE, GAINCTRL

The AD9709, AD9763, AD9765, AD9767 all allow the gain of each channel to be independently set by connecting one  $R_{SET}$  resistor to FSADJ1 and another  $R_{SET}$  resistor to FSADJ2. To add flexibility and reduce system cost, a single  $R_{SET}$  resistor can be used to set the gain of both channels simultaneously.

When GAINCTRL is low (i.e., connected to AGND), the independent channel gain control mode using two resistors is enabled. In this mode, individual  $R_{SET}$  resistors should be connected to FSADJ1 and FSADJ2. When GAINCTRL is high (i.e., connected to AVDD), the master/slave channel gain control mode using one resistor is

enabled. In this mode, a single  $R_{SET}$  resistor is connected to FSADJ1 and the resistor on FSADJ2 can be removed.

Note: Only parts with date code of 9930 or later have the Master/Slave GAINCTRL function. For parts prior to this date code, Pin 42 must be connected to AGND, and the part will operate in the two resistor, independent gain control mode.

#### OUTPUT CONFIGURATION

The AD9709, AD9763, AD9765, AD9767 have been designed to achieve optimum performance with the outputs used differentially. A transformer on the evaluation board (Mini-Circuits T1-1T) allows the conversion of the differential outputs to a single-ended signal. The bandwidth of this transformer allows low distortion operation from 350 kHz to well past the Nyquist bandwidth of the DAC when operating at its highest sampling rate.

Figure 9 shows a typical DAC output configuration. Both outputs drive a 50  $\Omega$  resistor as well as a transformer. The grounded centertap on the primary of the transformer causes the output of the DAC to swing around ground, allowing for wider p-p swing while still remaining within the output voltage compliance range of the DAC. On the evaluation board, these resistors are R5, R6, R7, and R8. This provides a full-scale differential output voltage of 0.67 V p-p when operating with  $I_{OUTFS} = 20$  mA and the transformer terminated with 50  $\Omega$ .

If the secondary of the transformer is terminated with 50  $\Omega$ , the DAC will then be capable of driving 0.5 dBm into this load at full-scale out.

C4, C5, C6, and C15 (10 pF) on the evaluation board, working together with the 50  $\Omega$  output resistors, form a low-pass filter which gives some amount of image rejection at higher output frequencies. In applications where an amplifier is used in place of the transformer, it is important that the capacitor values be chosen to limit the output slew rate of the DAC. If the output of the amplifier becomes slew rate limited, severe distortion can result.

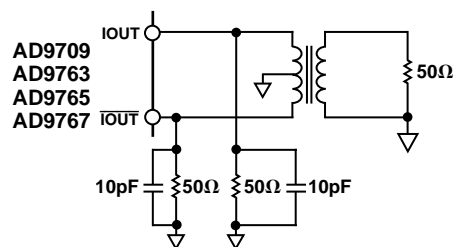

Figure 9. Typical DAC Output Configuration

## TROUBLESHOOTING

The dual DAC evaluation board has been designed to allow optimum performance from the AD9709, AD9763, AD9765, AD9767. However, many factors can contribute to suboptimal performance. The following is a list of potential problems and their likely sources.

### **Problem—No signal or reduced signal on the output.**

Is power applied correctly? Use an oscilloscope to verify that the input data pins are switching and that the clock is present on the input. Make sure that the output transformer is in place. Do the data input logic levels match the DVDD being applied (3 V or 5 V)? Does the clock pass through the input threshold, roughly one-half of DVDD? If the internal reference is being used, make sure that 1.2 V is present at FSADJ1, FSADJ2 and REFIO. Make sure that R9 and R10 are in place next to these test points.

### **Problem—Signal and images appear at the DAC output at twice or half the expected frequency.**

The DAC is in the incorrect mode (Dual DAC or Interleaving). Make sure that the mode select jumper in the top right corner of the eval board is set to the correct position. This jumper must be in one position or the other and cannot be allowed to float.

### **Problem—Unusually high amount of noise on the output.**

With an oscilloscope, verify the relative timing between the data transition and the clock input as described in the Clock Timing Performance section. Check to make sure that the clock for the data source is synchronized with the clock input to the DAC.

### **Problem—Can not match noise specifications from data sheet.**

Is a low jitter clock being used? When generating a single tone, does the spectrum analyzer show skirting around the tone at the noise floor? This is a symptom of clock jitter.

### **Problem—Can not match distortion spec.**

Is the output signal from the DAC seeing 50  $\Omega$ ? Is the voltage on the output of the DAC within the compliance range of  $\pm 1$  V? Is the DAC output overdriving the spectrum analyzer input? Try increasing the spectrum analyzer input attenuation to see if the distortion products drop. If they do, the analyzer is being overdriven.

POWER DECOUPLING AND INPUT CLOCKS

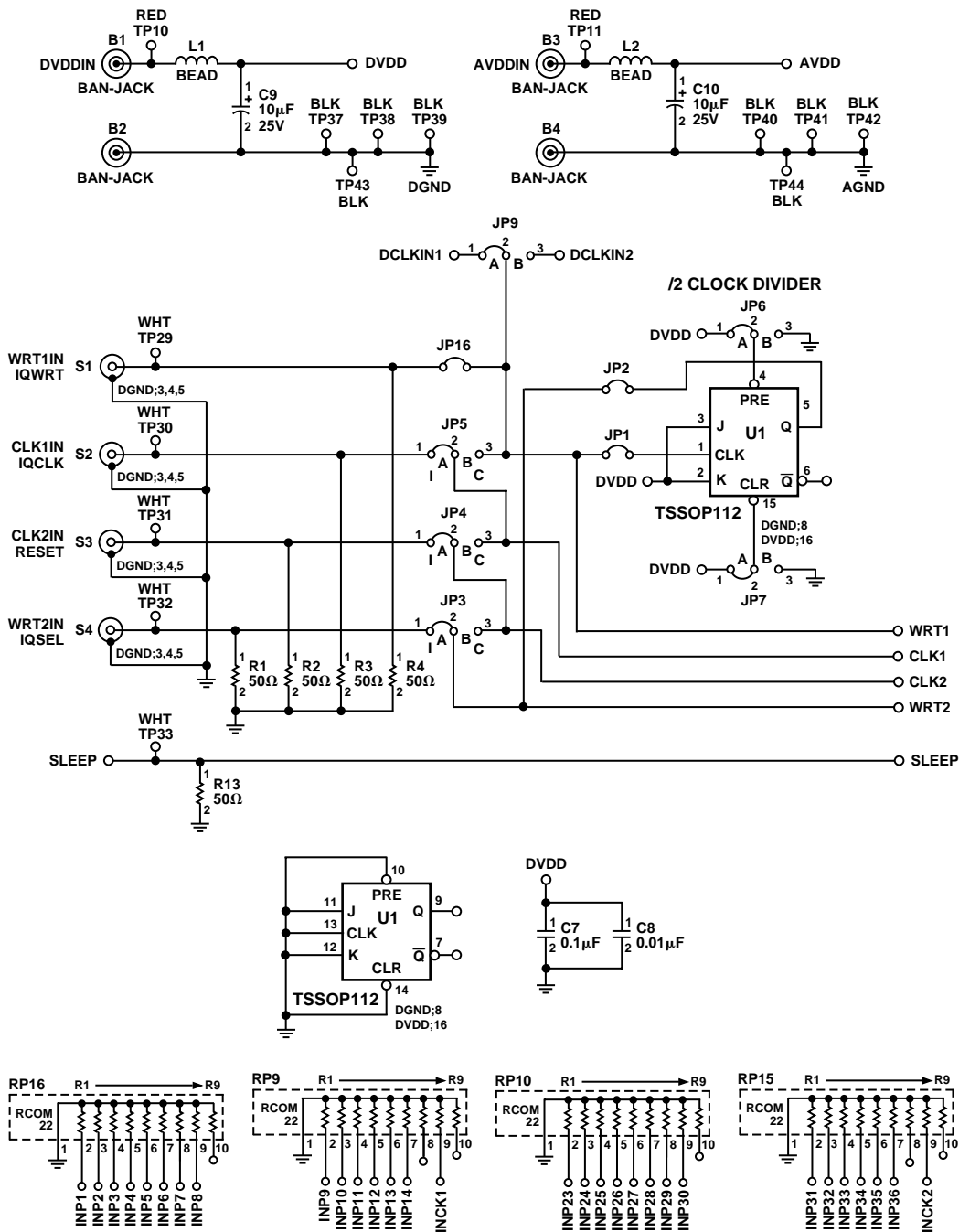

Figure 10. Power Decoupling and Clocks on Dual DAC Evaluation Board

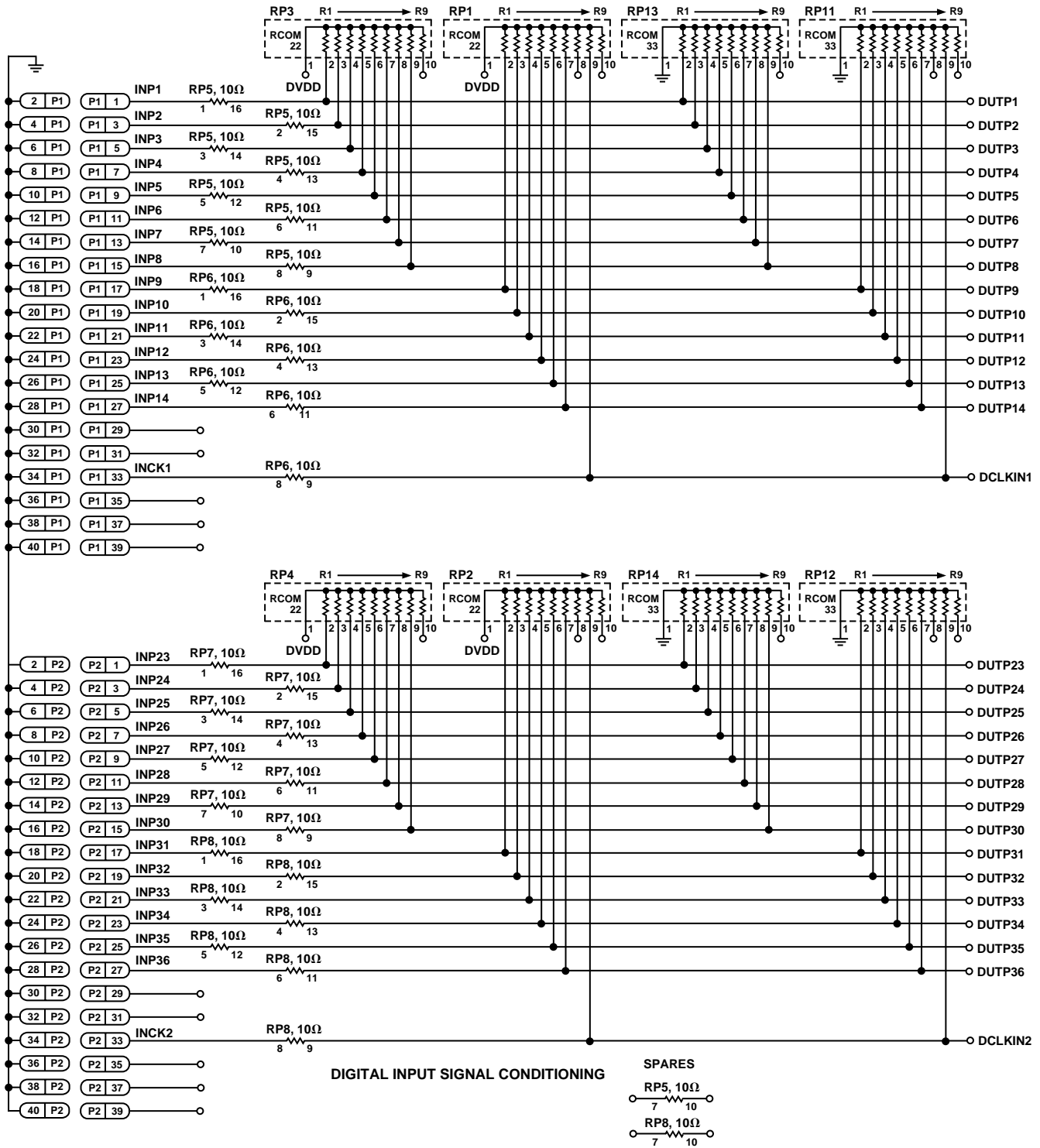
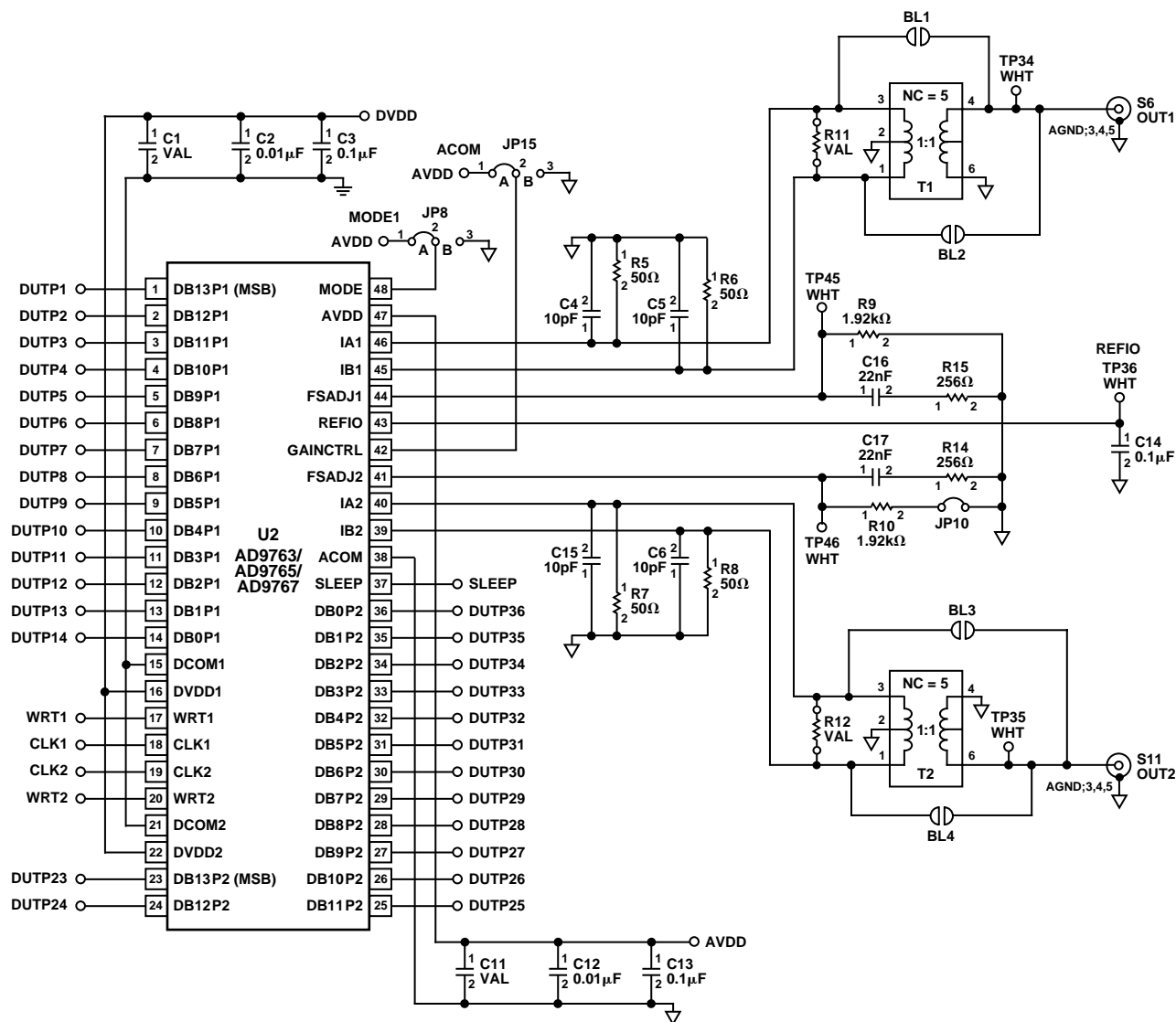

Figure 11. Digital Input Signal Conditioning





DUT AND ANALOG OUTPUT SIGNAL CONDITIONING

Figure 12. Output Signal Conditioning

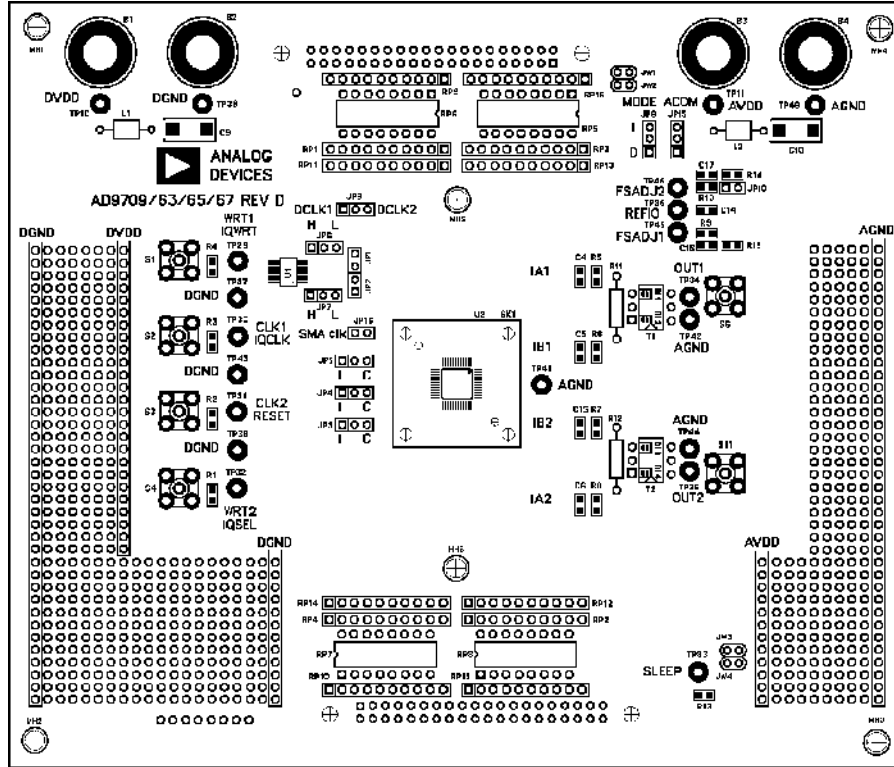

Figure 13. Assembly, Top Side

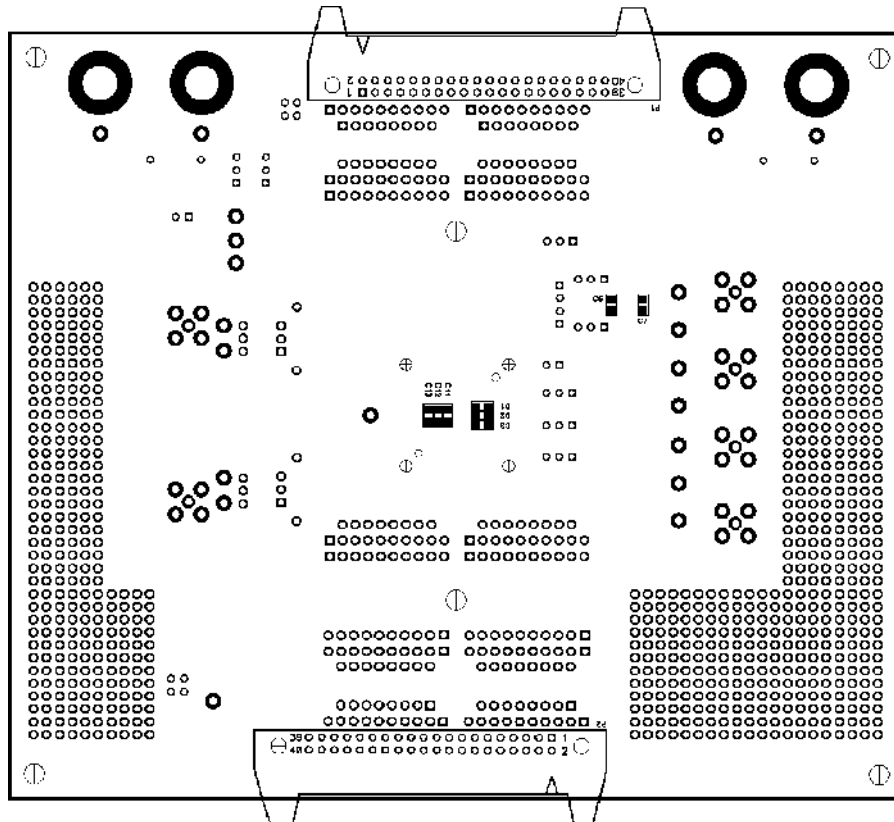

Figure 14. Assembly, Bottom Side

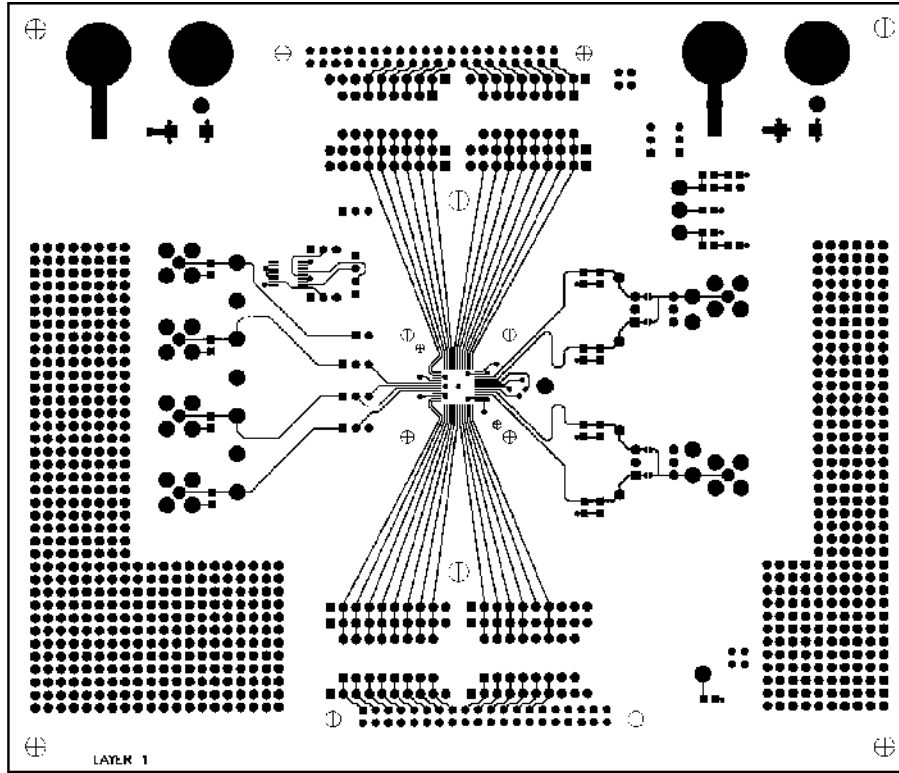

Figure 15. Layer 1, Top Side

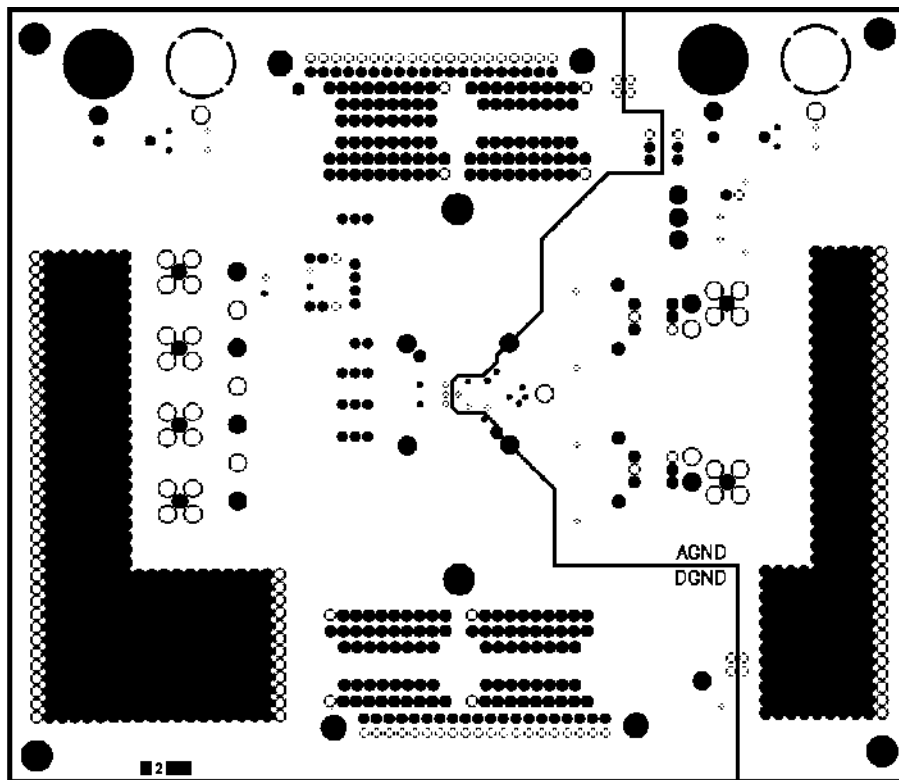

Figure 16. Layer 2, Ground Plane

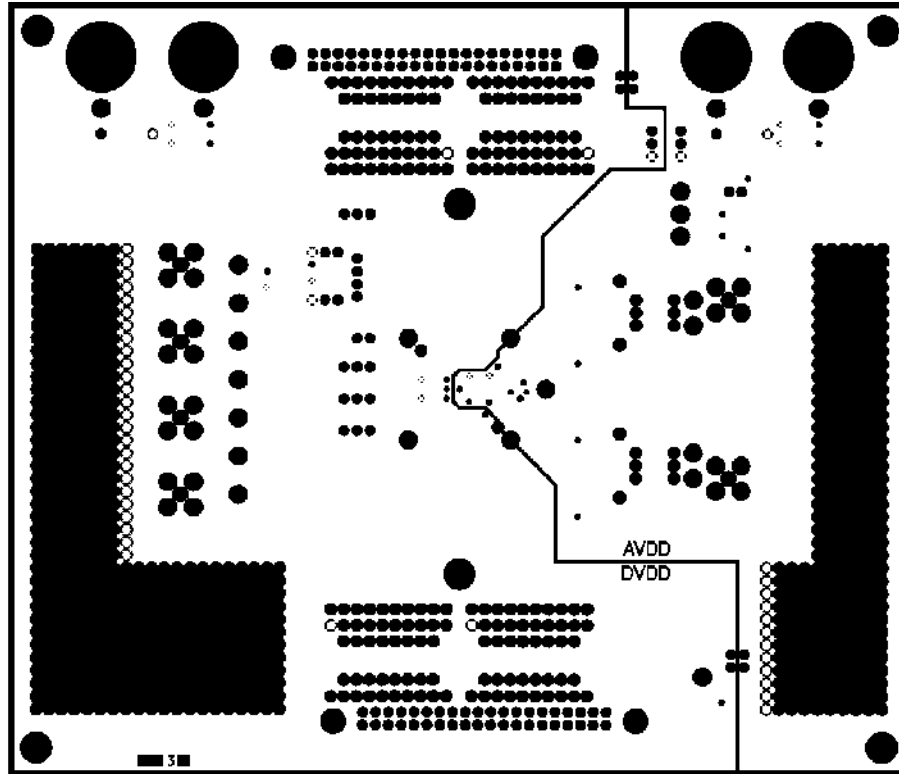

Figure 17. Layer 3, Power Plane

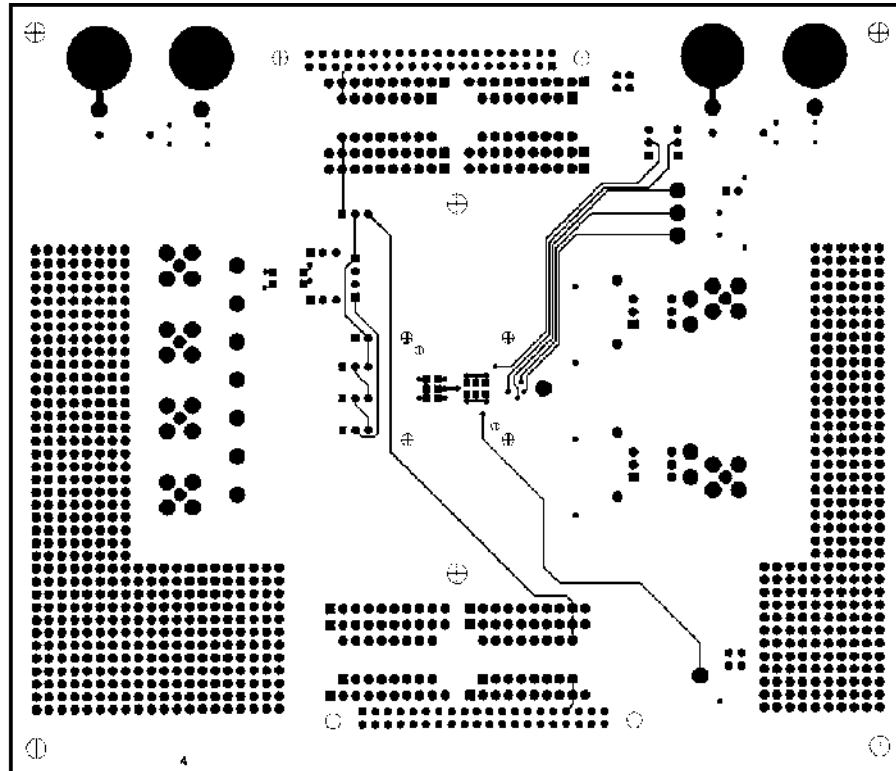

Figure 18. Layer 4, Bottom Side