

## Differential and Multiplying D/A Converter Applications

### INTRODUCTION

The introduction of low-cost monolithic D/A converters has simplified data acquisition and control system design. This application note describes several new applications using the multiplying capability and dual complementary current outputs of the Analog Devices DAC-08.

- CMOS, TTL, DTL, HTL, ECL, PMOS COMPATIBLE 2μA LOGIC INPUTS
- 85NSEC SETTLING TIME TO ±1/2LSB
- DUAL COMPLEMENTARY OUTPUTS WITH HIGH IMPEDANCE AND -10V TO +18V VOLTAGE COMPLIANCE
- HIGH SPEED MULTIPLYING REFERENCE INPUT
- ±4.5V TO ±18V 33mW AT ±5V
- EXTERNAL COMPENSATION FOR MAXIMUM BANDWIDTH
- ADJUSTABLE LOGIC INPUT THRESHOLD V<sub>TH</sub> = V<sub>LC</sub> + 1.4V

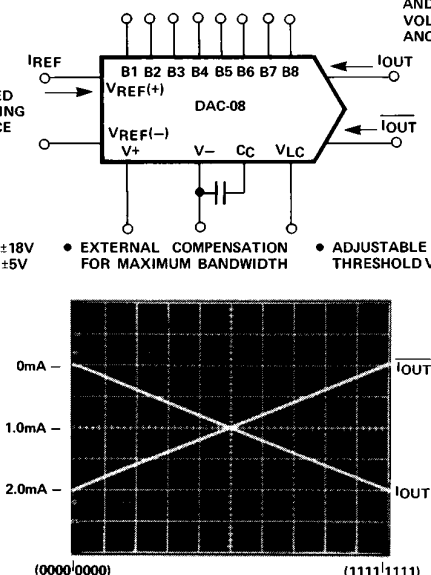

Figure 1. The Universal DAC

### MULTIPLYING DAC BASICS

A multiplying DAC has an analog output which is the product of a digital input word and a reference voltage and can be expressed as:

$$(1.) E_O = E_{REF} \left( \frac{A_1}{2} + \frac{A_2}{4} + \frac{A_3}{8} + \frac{A_4}{16} + \frac{A_5}{32} + \frac{A_6}{64} + \frac{A_7}{128} + \frac{A_8}{256} \right)$$

For a current reference, current output DAC, the expression becomes:

$$(2.) I_O = I_{REF} \left( \frac{A_1}{2} + \frac{A_2}{4} + \frac{A_3}{8} + \frac{A_4}{16} + \frac{A_5}{32} + \frac{A_6}{64} + \frac{A_7}{128} + \frac{A_8}{256} \right)$$

The DAC-08 has complementary/differential current outputs, and  $\bar{I}_O$  has a complement expressed as:

$$(3.) \bar{I}_O = I_{FS} - I_O \text{ for all input logic states.}$$

The relationship of  $I_{REF}$  to  $I_O$  and  $\bar{I}_O$  is illustrated in Figure 2 and in Figure 3, the basic DC reference connections. References may be either positive or negative, and a bipolar output voltage may be achieved using the high compliance current outputs alone or with an output operational amplifier. The simplest form of a multiplying DAC accepts a unipolar varying reference input.

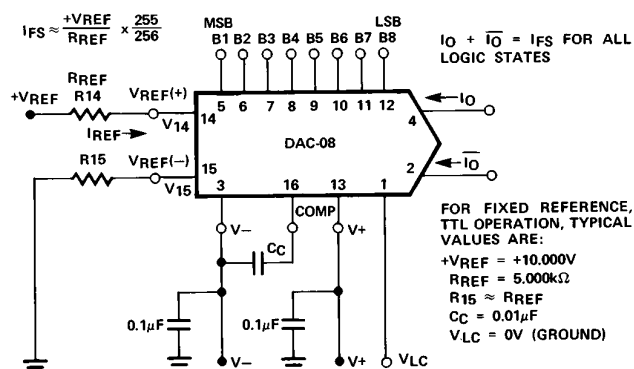

- NOTES:
1. R<sub>REF</sub> SETS I<sub>FS</sub>. R<sub>15</sub> IS FOR BIAS CURRENT CANCELLATION.
  2. PINS 14 AND 15 ARE OP AMP INPUTS, SO V<sub>14</sub> ≈ V<sub>15</sub>.

Figure 2. Positive Reference Connection

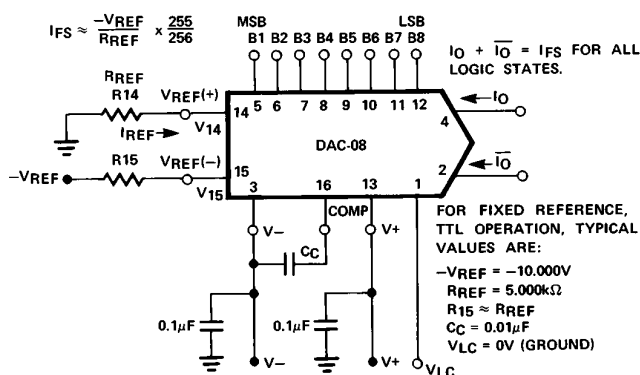

- NOTES:
1. R<sub>REF</sub> SETS I<sub>FS</sub>. R<sub>15</sub> IS FOR BIAS CURRENT CANCELLATION.
  2. PINS 14 AND 15 ARE OP AMP INPUTS, SO V<sub>14</sub> ≈ V<sub>15</sub>.

Figure 3. Negative Reference Connection

## BIPOLAR REFERENCES

Operation with bipolar references is achieved by modulating  $I_{REF}$  as shown in Figure 5. To aid in understanding bipolar operation, see the equivalent circuit in Figure 4. The reference inputs of the DAC-08 are op amp inputs —  $V_{REF(+)}$  being the inverting input and  $V_{REF(-)}$  being the noninverting input. Excellent gain linearity of the reference amplifier allows multiplying operation over a range of  $I_{REF}$  of  $4\mu A$  to  $4mA$  with monotonic operation from less than  $100\mu A$  to  $4mA$ .

## REFERENCE AMPLIFIER COMPENSATION

AC reference applications will require the reference amplifier to be compensated using a capacitor from Pin 16 to  $V_-$ . The value of this capacitor depends on the impedance presented to Pin 14: for  $R_{IN}$  values of 1.0, 2.5 and 5.0k $\Omega$ , minimum values of  $C_C$  are 15, 37, and 75pF. Larger values of  $R_{IN}$  require proportionately increased values of  $C_C$  for proper phase margin.

## FAST PULSED OPERATION

For fastest multiplying response, low values of  $R_{IN}$  enabling small  $C_C$  values should be used. For  $R_{IN}=1k\Omega$  and  $C_C=15pF$ ,

the reference amplifier slews at  $4mA/\mu s$  enabling a transition from  $I_{REF} = 0$  to  $I_{REF} = 2mA$  in 500ns. If  $R_{IN}$  or the parallel equivalent resistance at Pin 14 is less than  $200\Omega$ , no compensation capacitor is necessary, and a full-scale transition requires only 16ns.

## TWO-QUADRANT MULTIPLICATION

There are two forms of two-quadrant multiplication: bipolar digital, where the digital input word controls output polarity, and bipolar analog, where the analog reference input controls output polarity.

Bipolar digital two-quadrant multiplication is shown in Figure 6 with the output polarity being controlled by an offset-binary-coded digital input word.

Bipolar analog two-quadrant multiplication is shown in Figure 7. A bipolar reference voltage is connected to the upper DAC-08 and modulates the reference current by  $\pm 1.0mA$  around a quiescent current of 1.1mA. The lower DAC-08 also has a reference current of 1.1mA; due to the parallel digital inputs, the lower DAC-08 effectively subtracts out the quiescent 1.1mA of the upper DAC-08's reference current at all in-

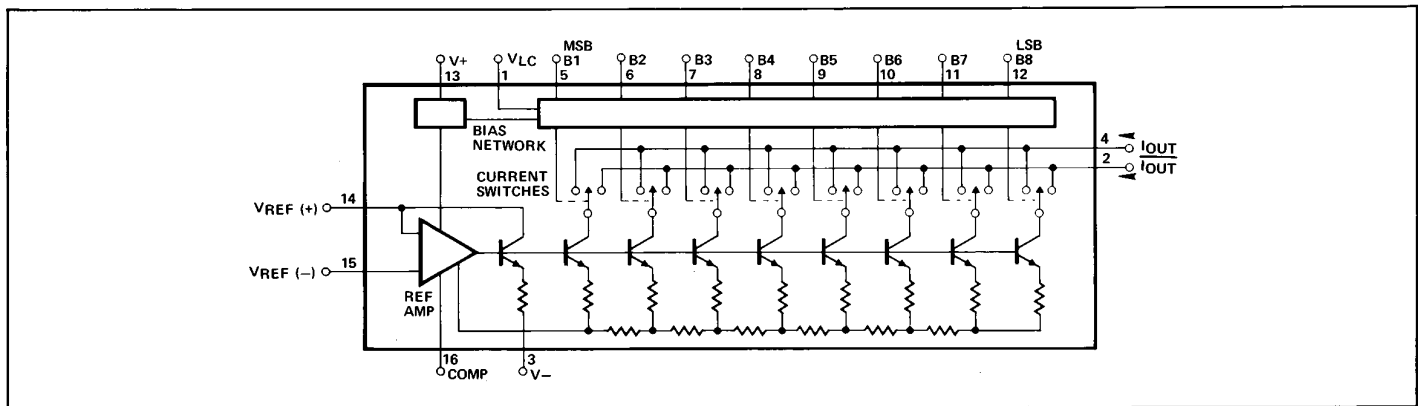

Figure 4. DAC-08 Equivalent Circuit

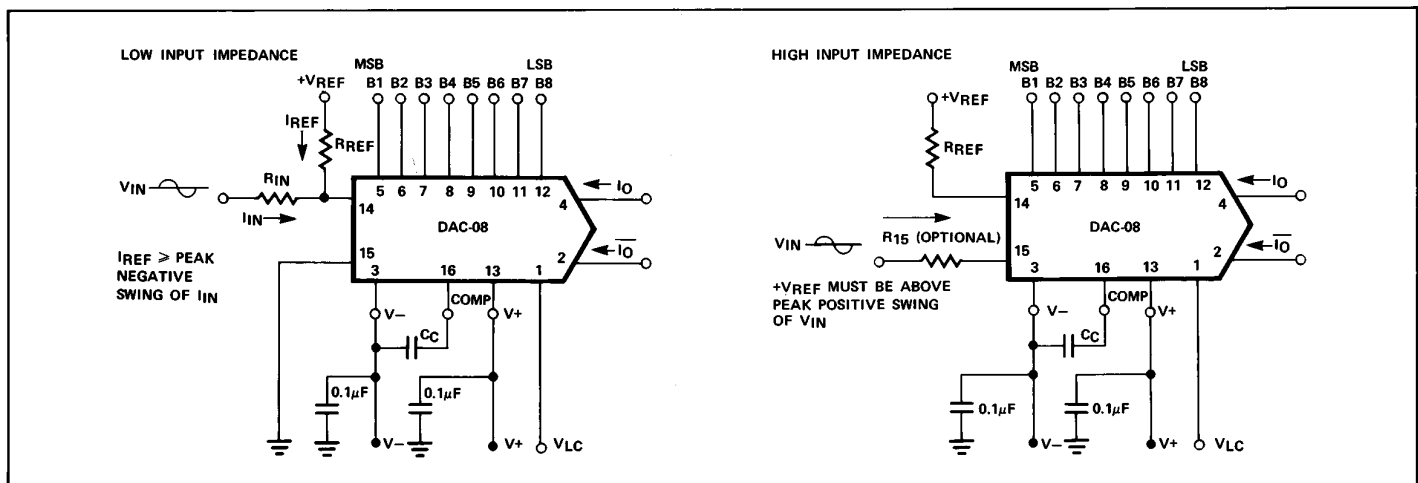

Figure 5. Bipolar Reference Connections

put codes, since the voltage across R3 varies between -10V and 0V. Thus, the output voltage,  $E_o$ , is a product of a digital input word and a bipolar analog reference voltage.

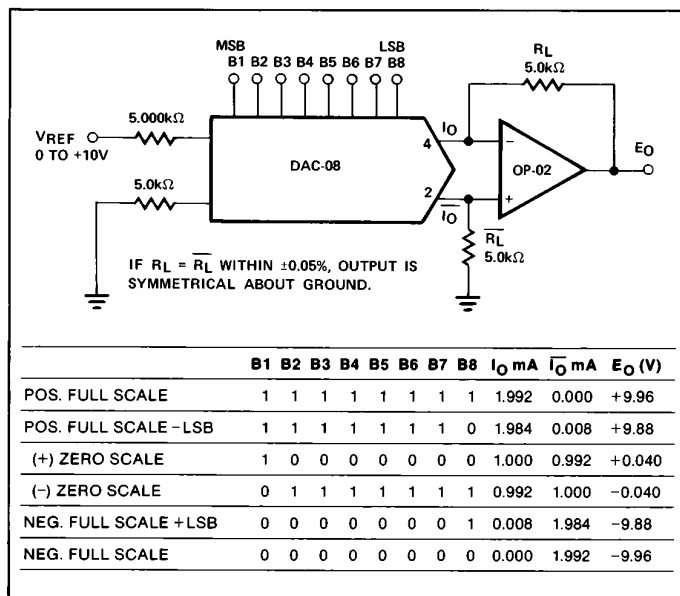

Figure 6. Bipolar Digital Two-Quadrant Multiplication (Symmetrical Offset Binary)

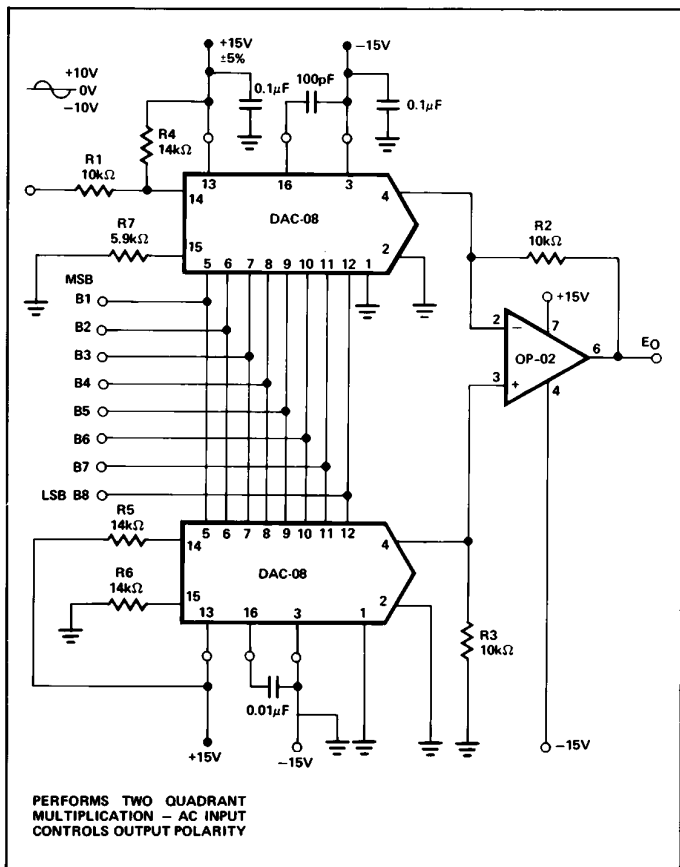

Figure 7. Bipolar Analog Two-Quadrant Multiplication (DC-Coupled Digital Attenuator)

## FOUR-QUADRANT MULTIPLICATION

Four-quadrant multiplication combines the two forms of two-quadrant multiplication. Output analog polarity is controlled by either the analog input reference or by the offset binary digital input word. One implementation of this function with the DAC-08 is shown in Figure 8 with output current values listed in Table 1.

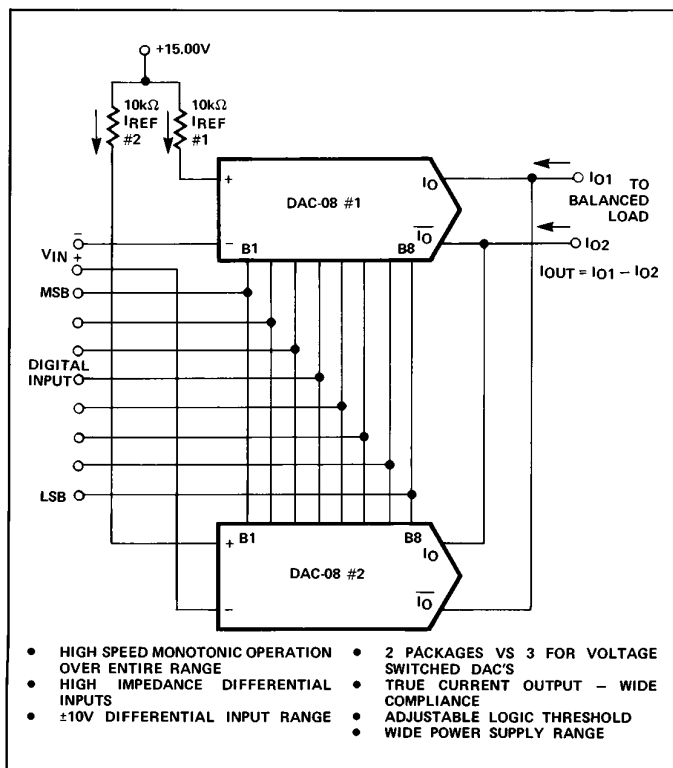

Figure 8. Four-Quadrant Multiplying DAC with Impedance Input

The four-quadrant multiplying DAC circuit shown accepts a differential voltage input and produces a differential current output. An output op amp is not shown because it is not always required; many applications are more suited for high output compliance (-10V to +18V) differential current outputs. Typical balanced loads include transformers, transducers, transmission lines, bridges and servos.

Operation of the four-quadrant multiplier may be more easily visualized by considering that if either  $V_{IN} = 0V$  or the offset binary digital input code is at midscale (corresponding to zero), then a change in the other input will not affect the output. Zero multiplied by any number equals zero.

A common mode current will be present at the output and must be accommodated by the balanced load. A pair of matched resistors may be used at the outputs to shunt most of the common mode current to ground, thus reducing the common mode voltage swing at the output.

**Table 1. Four-Quadrant Multiplying Current Values in Figure 8.**

DIGITAL INPUT	V <sub>IN(+)</sub>	V <sub>IN(-)</sub>	V <sub>IN DIFF.</sub>	I <sub>REF #1</sub> (mA)	I <sub>REF #2</sub> (mA)	I <sub>O#1</sub> (mA)	I <sub>O#2</sub> (mA)	I <sub>O1</sub> (mA)	I <sub>O#2</sub> (mA)	I <sub>O#1</sub> (mA)	I <sub>O2</sub> (mA)	I <sub>OUT DIFF.</sub>
1111 1111	+5V	-5V	+10V	2.000	1.000	1.992	0	1.992	0.996	0	0.996	0.996mA
1000 0000	+5V	-5V	+10V	2.000	1.000	1.000	0.496	1.496	0.500	0.992	1.492	0.004mA
0111 1111	+5V	-5V	+10V	2.000	1.000	0.992	0.500	1.492	0.496	1.000	1.496	-0.004mA
0000 0000	+5V	-5V	+10V	2.000	1.000	0	0.996	0.996	0	1.992	1.992	-0.996mA
1111 1111	0V	0V	0V	1.500	1.500	1.494	0	1.494	1.494	0	1.494	0.000mA
1000 0000	-10V	-10V	0V	2.500	2.500	1.250	1.240	2.490	1.250	1.240	2.490	0.000mA
0111 1111	+10V	+10V	0V	0.500	0.500	0.248	0.250	0.498	0.248	0.250	0.498	0.000mA
0000 0000	0V	0V	0V	1.500	1.500	0	1.494	1.494	0	1.494	1.494	0.000mA
1111 1111	-5V	+5V	-10V	1.000	2.000	0.996	0	0.996	1.992	0	1.992	-0.996mA
1000 0000	-5V	+5V	-10V	1.000	2.000	0.500	0.992	1.492	1.000	0.496	1.496	-0.004mA
0111 1111	-5V	+5V	-10V	1.000	2.000	0.496	1.000	1.496	0.992	0.500	1.492	0.004mA
0000 0000	-5V	+5V	-10V	1.000	2.000	0	1.992	1.992	0	0.996	0.996	0.996mA

**HIGHEST SPEED FOUR-QUADRANT MULTIPLYING CONSIDERATIONS**

The configuration shown in Figure 10 makes use of the DAC-08's ability to operate in a fast-pulsed reference mode without compensation capacitors. This technique provides lowest full-scale transition times. An internal clamp allows quick recovery of the reference amplifier from a cutoff (I<sub>REF</sub> = 0) condition. This connection yields a reference slew rate of 16mA/μs which is relatively independent of R<sub>IN</sub> and V<sub>IN</sub> values.

Input resistances are not limited to 10kΩ. For example, 100kΩ resistors for R<sub>IN1</sub> and R<sub>IN2</sub> allow ±100V reference voltage inputs making this connection especially useful in high common mode voltage environments. Except for different reference treatment, operation and digital input coding are identical in the circuits shown in Figure 8 and in Figure 10; both have the transfer function shown in Figure 9.

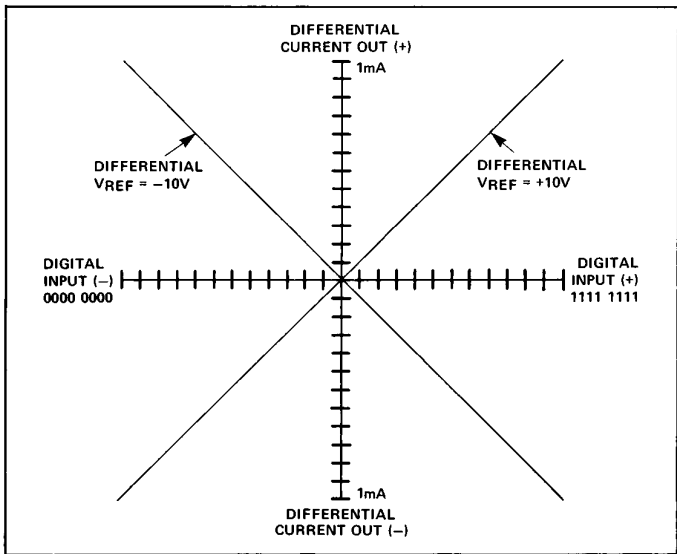

**Figure 9. Four-Quadrant Multiplying DAC Transfer Function**

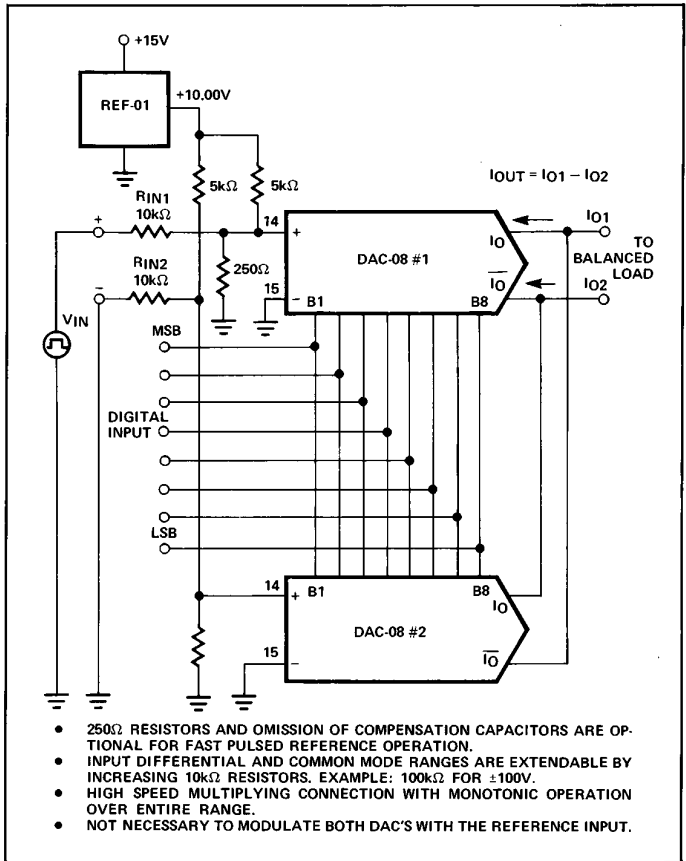

**Figure 10. Four-Quadrant Multiplying DAC with Extendable Input Range and Highest Speed**

**AC-COUPLED MULTIPLICATION**

Some multiplying DAC applications are more easily achieved with AC coupling. At the same time, a high impedance input is often required to avoid loading a relatively high source impedance. Both requirements are met by the circuits shown in Figure 11 and Figure 12 which use the compensation

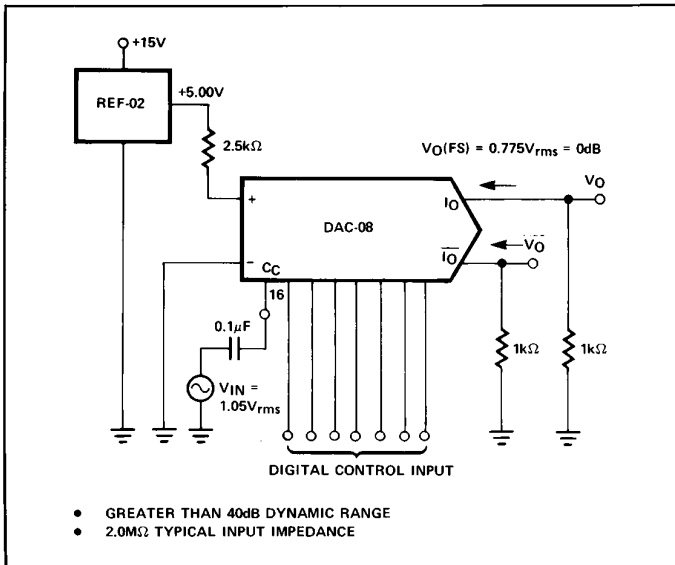

**Figure 11. High Input Impedance AC-Coupled Multiplication (Audio Frequency Digital Attenuator)**

capacitor terminal (C<sub>C</sub>) as an input. This is possible because C<sub>C</sub> is the base of a transistor whose emitter is one diode drop (0.7V) away from the R-2R ladder network common baseline internal to the DAC-08.

With a full-scale input code the output, V<sub>O</sub>, is flat to >200kHz and is 3dB down at approximately 1.0MHz making this type of multiplying connection useful even beyond the audio frequency range. Such a connection is illustrated in Figure 12 operating at 455kHz, the highest recommended operating frequency in this connection.

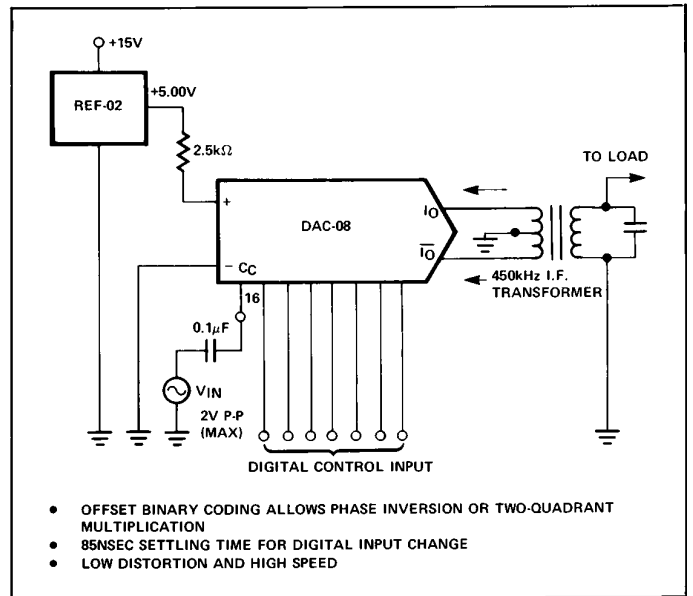

**Figure 12. High Input Impedance AC-Coupled Multiplication (I.F. Amplifier/Digital Attenuator)**

### DIFFERENTIAL AND RATIOMETRIC A/D CONVERSION

Complementary/differential current-source outputs and multiplying capability allow the DAC-08 to be used in differential and ratiometric A/D converter designs directly without signal conditioning amplifiers. This group of applications begins with the basic differential A/D converter and ratiometric A/D converter connections followed by more specific applications.

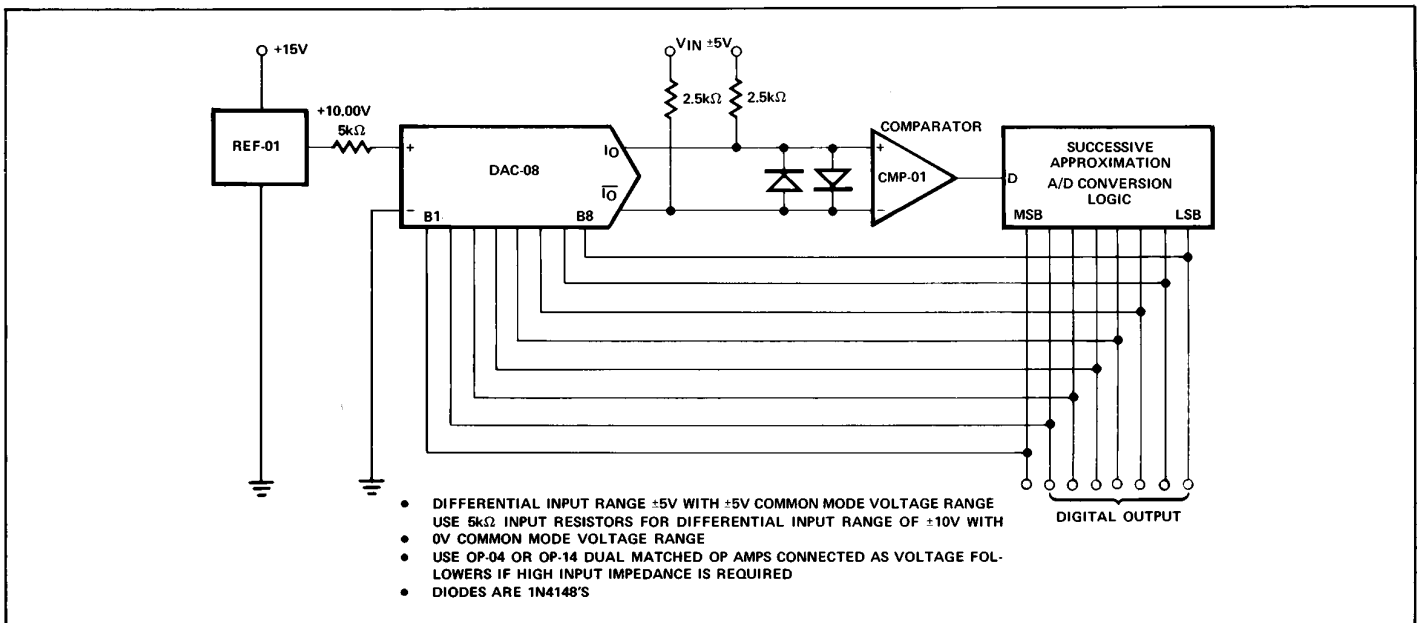

**Figure 13. Differential Input A/D Conversion Basic Connections**

These are extremely cost-effective designs due to their low parts count and simplicity. Alternative designs performing identical functions require instrumentation amplifiers for the differential-to-single-ended input signal conditioning and analog multipliers or dividers for the arithmetic functions.

### DIFFERENTIAL A/D CONVERSION

The circuit in Figure 13 uses the high voltage compliance current output capability of the DAC-08 and the high common mode voltage rejection of the CMP-01 to construct a differential input ADC without input signal conditioning.

A successive approximation ADC is constructed with four ICs: a REF-01 +10V reference, a 2502-type successive approximation register, a CMP-01 precision voltage comparator, and a DAC-08. As shown, the circuit converts an analog input in less than 2.0 $\mu$ s. For lower speed requirements, the A/D conversion logic can be the tracking or servo type consisting of up/down counters.

### FOUR-QUADRANT RATIOMETRIC A/D CONVERSION

Ratiometric A/D conversion with fully differential X and Y inputs is accomplished with the circuit in Figure 14. Here, one set of inputs,  $V_X$ , is connected in a manner similar to the circuit in Figure 13, and the other set of inputs  $V_Y$ , is connected in a multiplying fashion. Operation is as follows:  $I_{REF}$  for both the upper and the lower DAC-08 is modulated between 1mA and 3mA; and the resulting output currents are dif-

ferentially transformed into voltages by the 5k $\Omega$  resistors at the comparator's inputs and compared with the  $V_X$  differential input. When the conversion process is complete (comparator inputs differentially nulled to less than 1/2 LSB) a digital output is available which corresponds to the quotient of  $V_X/V_Y$ . Thus, four-quadrant ratiometric A/D conversion is achieved with four ICs and without instrumentation amplifiers.

### BRIDGE TRANSDUCER NULL

In many control systems, bridges must be nulled, and a digital representation of the bridge's error must be provided for computer monitoring and control. The circuit in Figure 15 accomplishes both tasks by using the DAC-08 complementary/differential current outputs to null the bridge with the DAC-08 connected in a tracking differential A/D converter configuration. The REF-02 reference voltage source provides both the bridge excitation voltage and the positive reference voltage for the DAC-08. Some of the advantages of this circuit are listed at the bottom of Figure 15.

### POWER MONITOR

Another differential current-input ADC is shown in Figure 16 with a transformer-coupled input. An up/down counter, a precision high-speed comparator, and the DAC-08 form a tracking A/D converter which continuously monitors the analog input. Two precautions must be observed: the common mode voltage at the comparator's inputs must not ex-

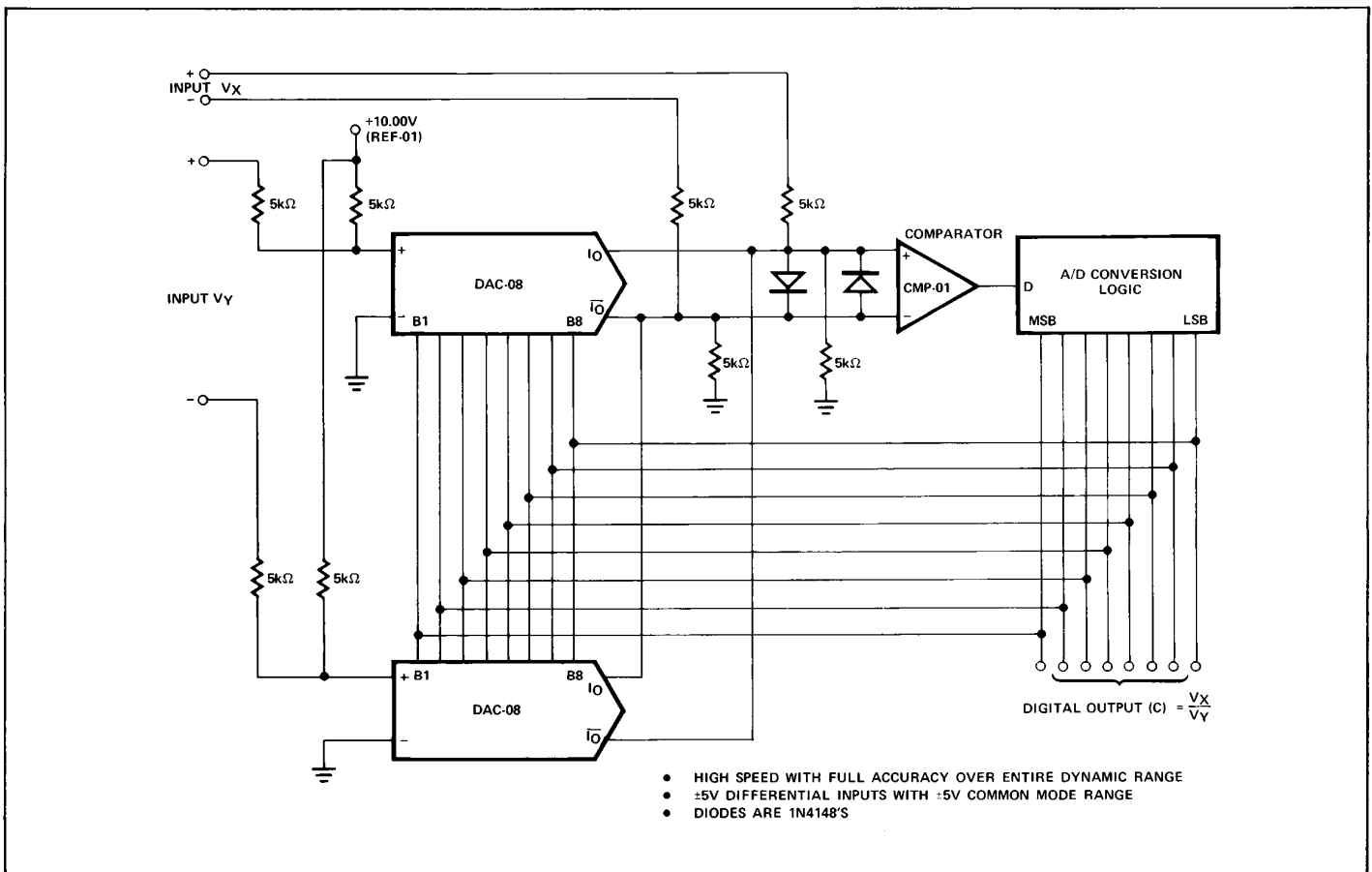

Figure 14. Four-Quadrant Ratiometric A/D Conversion Basic Connections

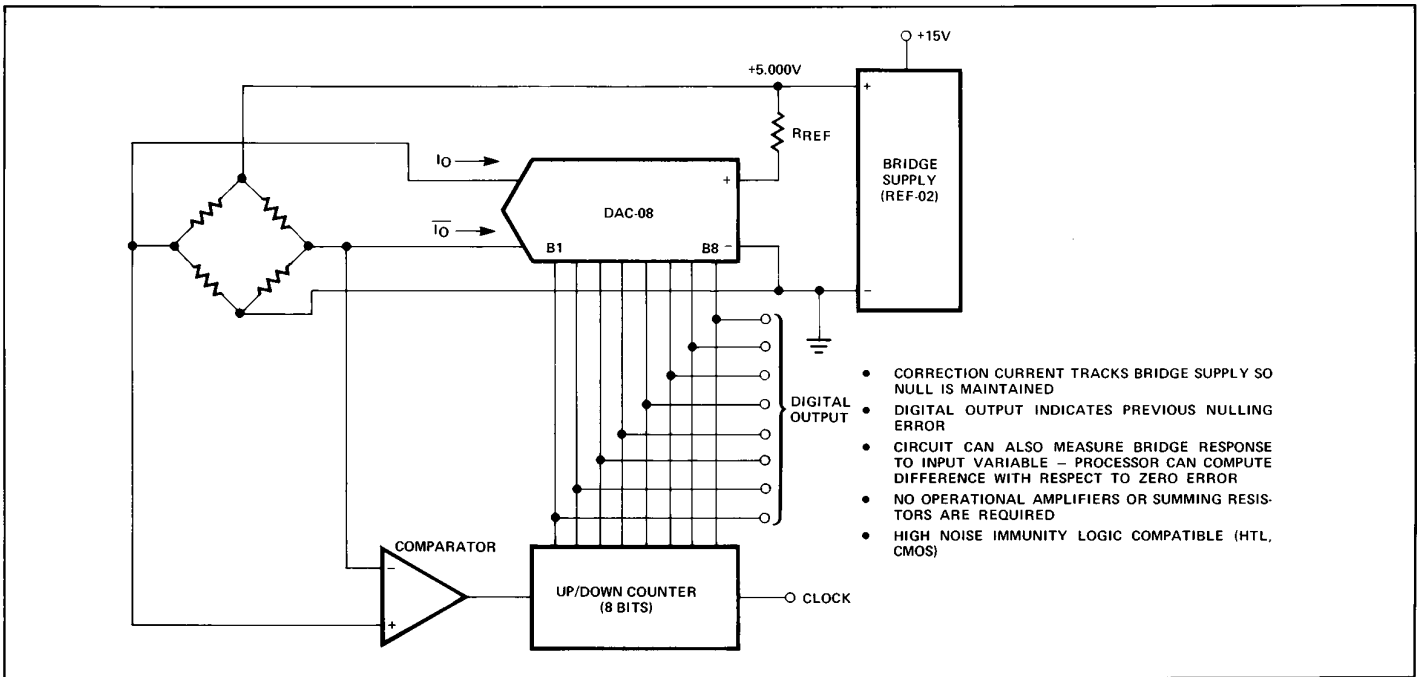

Figure 15. Bridge Transducer Null

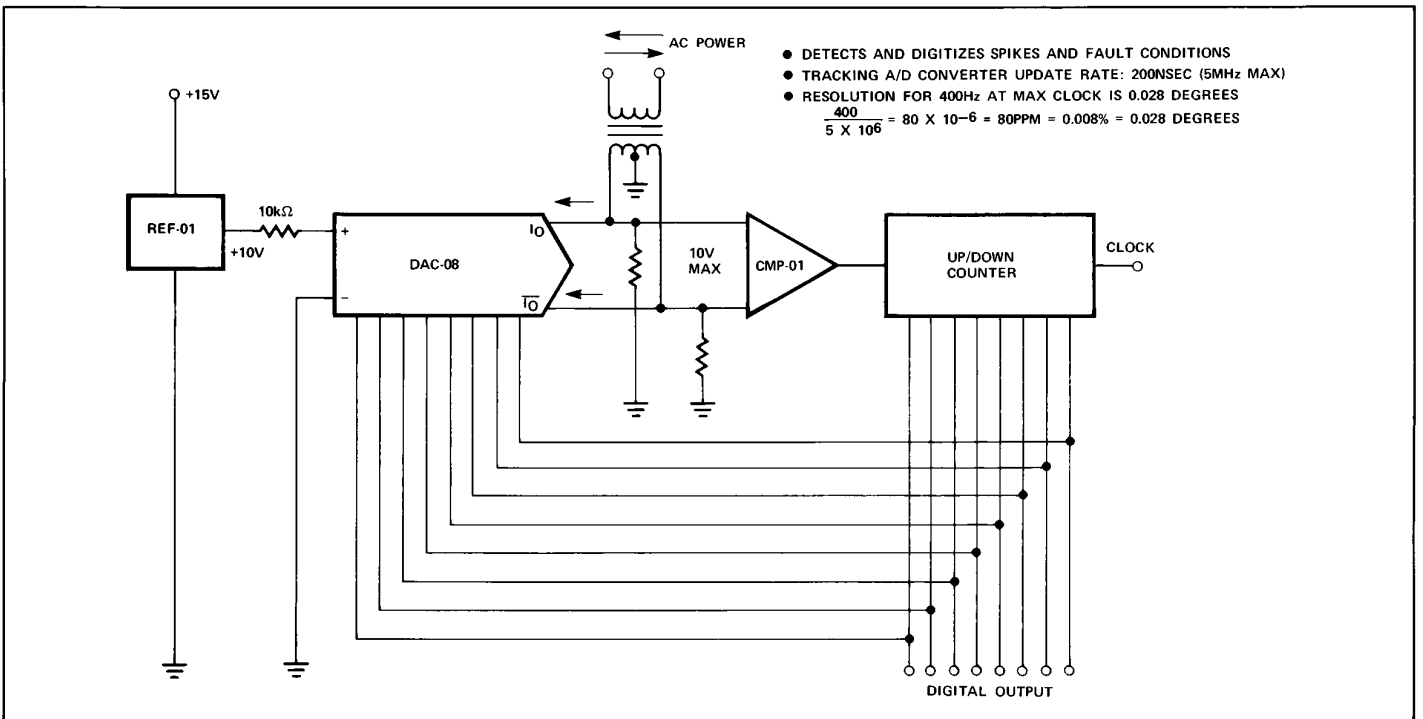

Figure 16. Power Fault Monitor and Detector

ceed  $\pm 10\text{V}$ ; and the differential voltage must not exceed 11V. Voltage-limiting resistors at the comparator's inputs are recommended.

### ALGEBRAIC DIGITAL COMPUTATION

Frequently, a digital arithmetic operation (addition, subtraction, multiplication, or division) must be performed, and an

analog output must be provided. Traditionally, the arithmetic operations are performed with several ICs, and the output drives a D/A converter. This section describes applications of the DAC-08 as an arithmetic building block, new design approaches that reduce the number of packages required in many applications. Today's low cost, versatile DACs merit a designer's consideration as arithmetic elements.

One benefit is not immediately apparent and deserves special mention. In all of these applications, the digital input words can be CMOS, TTL, DTL, NMOS, or MECL, because the DAC-08 interfaces with all of those logic families. In fact, the two input words may even be from different logic families to eliminate special level translators or interface circuitry. (See AN-17 "DAC-08 Applications Collection.")

The first arithmetic application is shown in Figure 17. Two DAC-08s perform a fast algebraic summation with a direct analog output. The circuit works by paralleling the outputs of two DAC-08s and summing their currents while driving a balanced load. The output is the algebraic sum of word "A" and word "B" in all four quadrants.

#### FOUR-QUADRANT DIGITAL MULTIPLICATION

High-speed multiplication of two 8-bit digital words with an analog output usually requires several logic packages and a D/A converter. The circuit in Figure 18 performs this function using only three ICs.

In Figure 18 DAC-08 number 1 and number 2 are connected as previously shown, and DAC-08 number 3 provides the analog reference inputs to DAC-08 number 1 and number 2. Those reference inputs are determined by digital input word "A." The circuit's output,  $I_{O1} - I_{O2}$ , is a differential current output which may be used to drive a balanced load.

Four-quadrant multiplication is thus performed by adding one more DAC-08 to the basic four-quadrant multiplying connection.

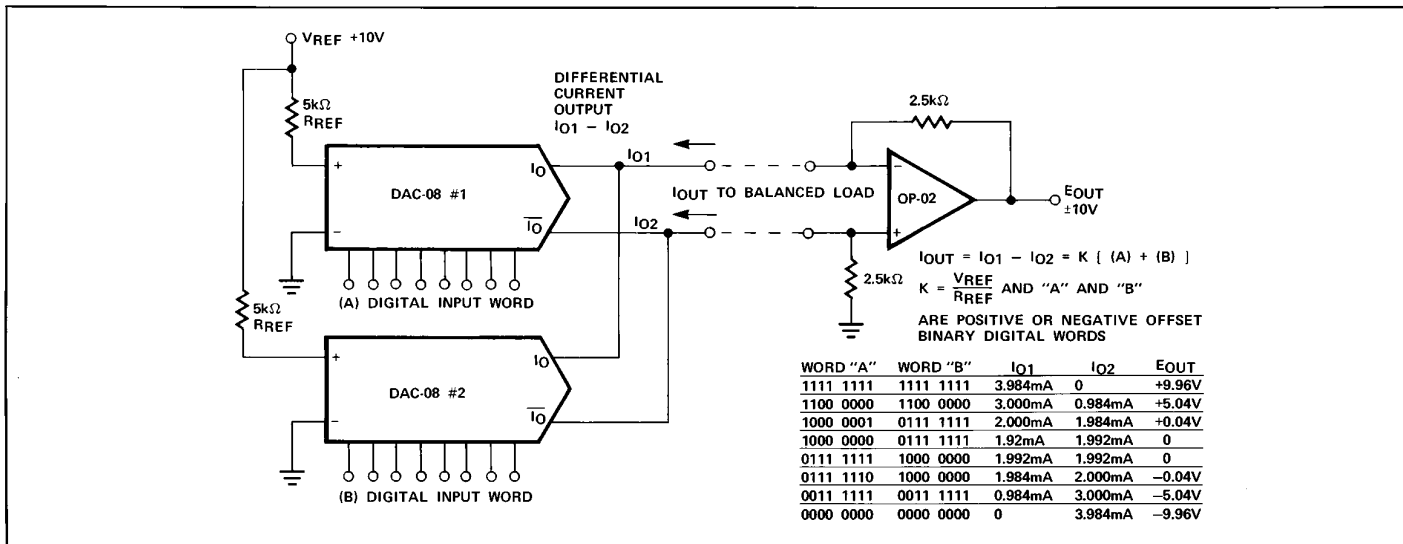

Figure 17. Four-Quadrant Algebraic Digital Computation

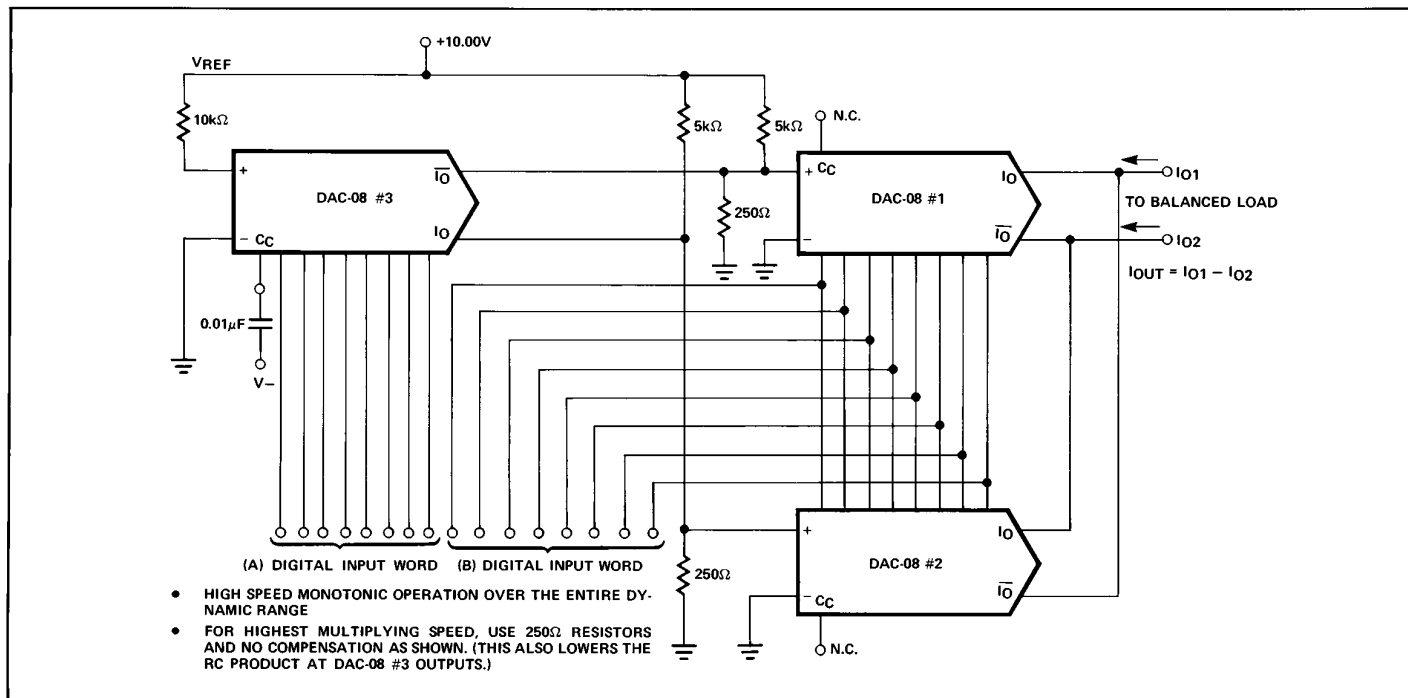

Figure 18. Four-Quadrant 8-Bit x 8-Bit Digital Multiplier