

# analog dialogue

A forum for the exchange of circuit technology: Analog and Digital, Monolithic and Discrete

NEW 3½ AND 4½-DIGIT DPM's (P. 7)  
Monolithic  $V_X V_Y / I_R$   
Complete Contents on Page 2

4½

3½

2½



system supply, thus eliminating the shielding, decoupling, etc., normally needed when the AC line must be routed near signal leads. Separate DC inputs to the converter and the display allow the OEM designer to minimize effects of display transients on conversion accuracy, economize regulated power, and by use of an external circuit, blank the display independently of the converter.

Reliability Components used in our DPM's are tested prior to and during each phase of manufacturing. Furthermore, each unit undergoes a 7-day burn-in prior to shipment to assure high reliability.

	AD2002 2½ Digit, Unipolar	AD2003 3½ Digit Differential	AD2004 4½ Digit High Performance
Full Scale Range	2½	3½	4½
Bus Current Impedance	Numitron Dashes Selectable at Input Yes	Numitron Dashes Selectable at Input Yes	Zero & Flashes Selectable at Input Yes
Overvoltage Protection without Damage	Single Ended Automatic Unipolar 0 to +1.99V 70mA typ./250mA max. (10% ohms in overload) 150V Sustained	Differential Floating Automatic 0 to +1.99V 70mA typ./250mA max. (10% ohms in overload) 150V Sustained	Floating Automatic 0 to +1.99V 70mA typ./250mA max. (10% ohms in overload) 150V Sustained
Accuracy	0.5% ±1 Digit 10mV 0°C to +50°C 1/20 digit/°C	0.1mV 0°C to +50°C 150ppm/°C	0.01% ±1 Digit 0.1mV 0°C to +50°C
Maximum Error of Reading			
Resolution			
Temperature Range Operating			
Temperature Coefficient			
Speed			
Internal Conversion/Sec			
External Conversion/Sec			
Hold & Read on Command			
Interface Signals (DTL/TTL Compatible)			
Inputs			
Externally Triggerable			
External Hold			
Bi-D Digits			
Overrange Signal			
Overload Signal			
Status Signal			
Polarity Signal			



**ANALOG DEVICES**



# Editor's Notes



## THOUGHTS ON FALL

Fall is a season of currents and crosscurrents. For some, it is the season of harvest, for others, the death of summer and a precursor of winter, for yet others, just a notch in the annual cycle. For the student, it is the beginning of a year fraught with unknown opportunities and possibilities; for the businessman, it is often also the beginning of a new year, a time for summing up, evaluating, scheming, planning, and doing.

Though the electron knows no season, we humans who reap the benefits of knowing its eternal rounds and wayward ways must still listen to the call of the calendar. And so, the time seems appropriate to look back—and ahead—while keeping our feet firmly planted in the present.

## FALL 1972

By any yardstick: sales, earnings, new products, market penetration, brand recognition, quality and quantity of products and employees, Analog Devices has prospered during Fiscal Year 1972.

Tangible evidence for readers of this journal has been profuse. From the vivid versatility of the Model 433  $[Y(Z/X)^m]$  and various modular multipliers, logarithmic and linear devices, to the successful creation of a practically bloodless revolution in digital panel meters (starting with the AD2001 last winter and inarked most recently by the two new delights noted on page 5), progress has been manifest.

But two product areas have carried the greatest burden of innovation and bread-and-butter growth during 1972; *converters*, marked by 16-bit A/D and D/A designs, reduced-cost-without-compromise-to-quality designs (ADC-10Z and ADC-12QZ), and ventures into higher speeds (DAC-10DF and MDA-11MF); and *linear integrated circuits*, distinguished by analog multiplier-dividers of ever-increasing simplicity, accuracy, and practicality (AD530, 531), op amps of decreasing drift (AD508), bias current (AD523), and response time (AD505), and instrumentation amplifiers that stand alone among IC's (AD520).

## CONVERTERS GO MONOLITHIC

Now, as the new year dawns, the monolithic revolution is coming to converters. In the next issue, we expect to describe the design, applications, and implications of a 10-bit *monolithic* digital-to-analog converter that will be pin-interchangeable with an existing hybrid type. It will be the first in a series of new products planned to bring the full benefits of IC technology to bear on the rapidly-increasing number of analog-digital interfaces, as measurement, computer, and display technology themselves grow in quantum jumps.

If you are not now on the mailing list of *Analog Dialogue*, use the reply card to ensure that you will receive future issues and share with us the continuing fruits of the marriage between analog-digital circuits and integrated-circuit technology. ▶▶▶

## AN INVITATION

dialogue 1. A conversation between two or more people. . . . 5. An exchange of ideas or opinions.<sup>1</sup> Sometimes the feeling grows that we have somehow failed in at least one aspect of the mission of *Analog Dialogue*. While the returns of reply cards and the interest in our products indicate that you are reading what we have to say, and that it probably meets your needs, it is a matter of concern to us that we have not succeeded in stimulating more than a few of our readers to seek to participate actively in the *Dialogue*.

We re-iterate our invitation to you, our readers, to take pen in hand and help us establish a "Readers' Notes" column as a regular feature. Welcomed are relevant applications ideas, "hints and kinks," puzzles (with solutions), technical queries, comments on what we've published, and suggestions for how to improve the *Dialogue*, addressed to the Editor (see below). ▶▶▶

## ON FUNCTIONS

For what useful function  $f(Z, X)$  is

$$\frac{\pi (Z/X)^{1.2125}}{2 (Z/X)^{1.2125} + 1}$$

an acceptable (within 0.75%) approximation? How would you implement it simply with analog circuit elements?

For the answers, see page 5. ▶▶▶

IN THIS ISSUE	
Editor's Notes . . . . .	2
Application Briefs	
<i>Root-Sum-of-Squares Circuits with the Model 433</i> . . . . .	3
<i>Trigonometric Operations with the 433</i> (Approximations of sin, cos, tan <sup>-1</sup> , with Non-Integral Powers) . . . . .	4-5
<i>Gate Responses Simplified</i> (for the Occasional Logic User) . . . . .	6
3½ and 4½-Digital Panel Meters . . . . .	7
Model 429 Wideband, Accurate Multiplier/Divider . . . . .	8
A ±200mA, ±15V Modular Power Supply . . . . .	8
Low-Cost High-Performance FET-Input Op Amp . . . . .	8
"Modules are at Home in Converter Manifold Boards" . . . . .	9
Monolithic Analog Multiplier/Dividers . . . . .	10,11
Two Dual Transistors and a Dual TRAK-FET . . . . .	11
"AD540 Low-Cost FET-Input IC Op Amp: A Best Buy" . . . . .	11
<i>Analog-Digital Conversion Handbook</i> (advertisement) . . . . .	12

<sup>1</sup>The American Heritage Dictionary of the English Language.

# analog dialogue

Route 1 Industrial Park, P.O. Box 280, Norwood, Mass. 02062

Published by Analog Devices, Inc., and available at no charge to engineers and scientists who use or think about I.C. or discrete analog, conversion, data handling and display circuits. Correspondence is welcome and should be addressed to Editor, *Analog Dialogue*, P.O. Box 280, Norwood, Massachusetts, U.S.A. 02062. Analog Devices, Inc., has representatives and sales offices throughout the world. For information regarding our products and their applications, you are invited to use the enclosed Business Reply card, write to the above address, or phone 617-329-4700, TWX 710-394-6577, Telex 710-394-6577, or cable ANALOG NORWOOD MASS.

# ROOT-SUM-OF-SQUARES CIRCUITS WITH THE 433

by Dan Sheingold

In Volume 6, No. 2, the Model 433\* multifunction analog module was introduced. It is a device that is characterized by the function:  $(10/V_R)Y(Z/X)^m$ , where all inputs and the output can have any value from 0 to +10V,  $V_R \cong 9V$ , and the exponent  $m$  can range from 0.2 to 5, as set by a resistance ratio. The useful jobs it can do at low cost include multiplication, division (ratios), exponentiation, rms computation, and vector sums.

In this Brief, use of the 433 for vector sums will be discussed at greater length. In a second Brief, in the following pages, we will touch on some new ideas developed by the author involving a few interesting circuits to obtain economical (but reasonably accurate) embodiments of trigonometric relationships.

## $\sqrt{X^2 + Y^2}$ : TWO WAYS

The 433 is used with two operational amplifiers to fulfill the relationship

$$(V_C + V_B)(V_C - V_B) = V_A^2 \quad (1)$$

whence  $V_C = \sqrt{V_A^2 + V_B^2}$  (2)

In concept, the equation may be embodied in two ways:

$$V_C = \frac{V_A^2}{V_C + V_B} + V_B \quad (3)$$

and 
$$V_C = \frac{V_A^2}{V_C - V_B} - V_B \quad (4)$$

In practice, the circuit embodying equation (3) leads to better results (Figure 1). The denominator is always at least as large as input  $V_A$ ; hence the closed-loop gain is  $\leq 1$ . The result is excellent stability and low noise, even for very small inputs.

Unfortunately, a circuit embodying equation (4) has appeared in some of our earlier literature through the appalling workings of Murphy's Law ("the worse of two approaches will always be published"). It can be made to work, but at the cost of large stabilizing capacitors, reduced bandwidth, and poor accuracy for low-level inputs.

Performance, adjustment, and choice of components are straight-forward. A feature of the circuit that does require some thought is the choice of input scaling, to avoid saturation of devices within the circuit. Figure 2 shows the "worst-case" situation, with specified 10V limits on all amplifier outputs. The "gating" factor is the output of amplifier A1, which takes the sum  $V_C + V_B$ . For the output of A1 to remain within

the 10V limit, the maximum values of  $V_A$  and  $V_B$  must lie within the envelope shown in the Figure. For the particular case of  $V_A = V_B$ , the inputs should not exceed 4.142V (output = 5.858V). As a practical matter, IC amplifiers are usually specified to have 12V minimum output with light loads: for both inputs at 5V (a "round" number) the output is 7.07V, and the output of A1 is 12.07V. With careful matching and adjustment, one can typically achieve errors less than 0.25% of the theoretical output for inputs from 0.1 to 10V.

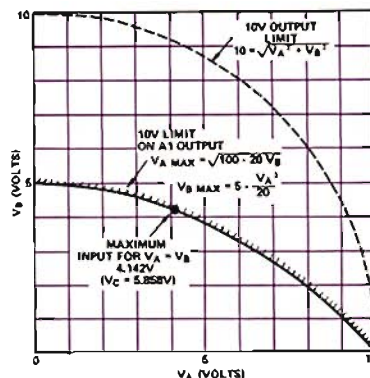

Figure 2. Input Voltage Limits (Using Amplifiers With 10V Output Specifications)

## MORE THAN TWO INPUTS

This unconventional approach to square-root of the sum-of-squares can be used for the more-general case of 3 or more input variables without the necessity of cascading operations on pairs of inputs. Simply sum  $n-1$  numerator terms, i.e.,

$$E_0 = \frac{V_1^2 + V_2^2 + \dots + V_{n-1}^2}{E_0 + V_n} + V_n \quad (5)$$

$$= \sqrt{V_1^2 + V_2^2 + \dots + V_n^2} \quad (6)$$

Figure 3 is a scheme that embodies this approach. Again, the principal constraint is imposed by the output specifications of amplifier A1. If all inputs have the same maximum value (and can have it simultaneously), for the maximum output of A1 to be less than  $E_{max}$ , that maximum input value  $V_{max}$  is

$$V_{max} = E_{max} / (1 + \sqrt{n}) \quad (7)$$

For  $E_{max} = 10V$ , corresponding values of  $n$  and  $V_{max}$  are 2: 4.14V, 3: 3.66V, 4: 3.33V, 5: 3.09V, 6: 2.90V, etc. ▶▶▶

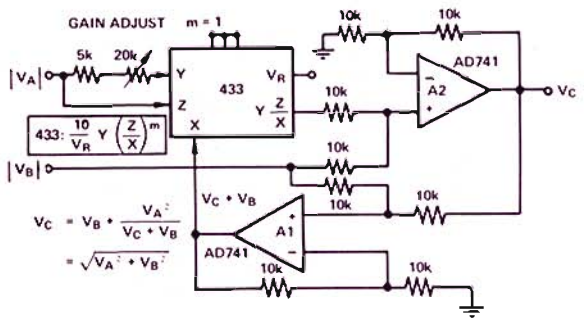

Figure 1. Preferred Circuit to Compute  $\sqrt{V_A^2 + V_B^2}$

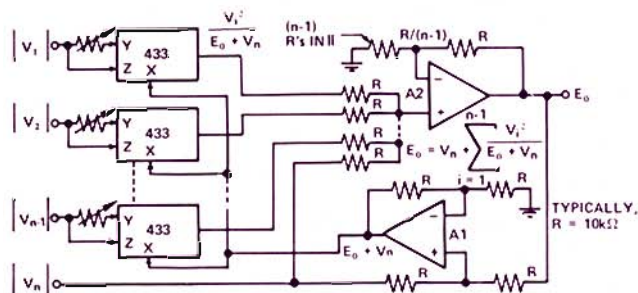

Figure 3. Extension of the Technique to  $n$  Input Signals

\*For information on the 433, Request H20.

## TRIGONOMETRIC OPERATIONS WITH THE 433 (The Powers of Non-Integral Exponents)

by Dan Sheingold

A new approximation technique appears to presage promising results in the low-cost analog simulation of trigonometric relationships. Applications include low-cost resolvers, coordinate transformations (especially Cartesian-to-polar), and generation of time functions. Further extensions of the basic idea will be useful in such applications as "linearizing" the outputs of transducers having nonlinear distortion (thermocouples and strain gages, for example) and the generation of arbitrary functions having no discontinuities (as compared to functions simulated by piecewise-linear approximations).

The results reported on are preliminary and subject to refinement by the author, as well as by readers having more considerable mathematical talents. While the application of the technique is entirely new in our experience, there may have been precursors in the literature, of which we are unaware. (We would appreciate enlightenment in this regard.)

The basic idea, the use of non-integral exponents, has been germinating in the back of our mind since the days of the obsolete (35+ watts) GAP/R K4-FG polynomial Function Generator (1951). Two important conditions were required to bring the idea to the fore:

1. The availability of a low-cost, reasonably-accurate multiplier-divider component incorporating arbitrary and easily-adjustable exponents, to wit, the present Analog Devices Model 433 (see preceding page).
2. The availability of computing devices capable of performing large numbers of transcendental computations in a short period of time, for evaluation of approximation schemes. (Bouquets to the HP-35!)

### SIN $\theta$

An example that illustrates the power of the technique is the embodiment of  $\sin \theta$ , to within  $\frac{1}{4}\%$  in a single quadrant. Most of our readers are familiar with the infinite series for  $\sin \theta$

$$\sin \theta = \theta - \frac{\theta^3}{3!} + \frac{\theta^5}{5!} - \dots \quad (1)$$

Approximations using modified coefficients allow truncation of the series to 3 terms ( $\theta^5$ ) with less than 0.02% error<sup>1</sup>, and to 2 terms with 1.35% error.

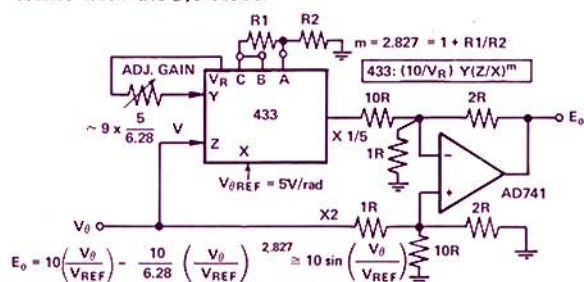

Figure 1. Basic Circuit for Approximating  $\sin \theta$

<sup>1</sup> See *Handbook of Mathematical Functions*, U.S. Department of Commerce, National Bureau of Standards, edited by Abramowitz and Stegun, 1968, available from the Superintendent of Documents, Washington, D.C. 20402 (1046 pp.).

However, by using non-integral exponents, in addition to modified coefficients, one can obtain less than 0.25% error (one quadrant) with just two terms! A reasonably close approximation is

$$\sin \theta \cong \theta - \frac{\theta^{2.827}}{6.28} \quad (0 \text{ to } \pi/2 \text{ radians}) \quad (2)$$

It can be implemented with a simple circuit composed of a 433 and a single operational amplifier. A circuit and a plot of the theoretical errors will be found in Figures 1 and 2.

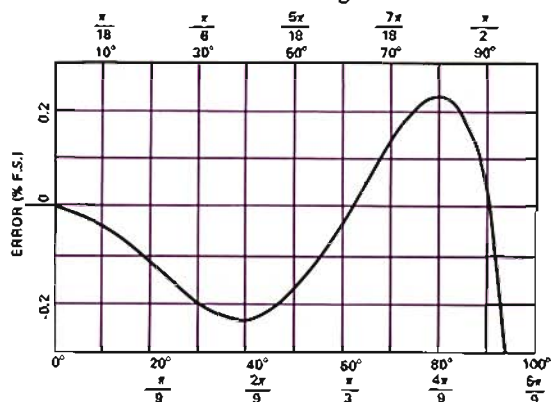

Figure 2. Theoretical Errors of  $\sin \theta$  Approximation (% F.S.)

For "round-number" scaling, one might typically choose either 5V/radian or 1V/10°. Voltage equivalents for both are given in the table.

Radians	Degrees	Volts	Degrees	Radians	Volts
0	0	0	0	0	0
0.1	5.73	0.5	10	0.1745	1
0.2	11.46	1.0	20	0.3491	2
0.3	17.19	1.5	30	0.5236	3
0.4	22.92	2.0	40	0.6981	4
0.5	28.65	2.5	45	0.7854	4.5
0.6	34.38	3.0	50	0.8727	5
0.7	40.11	3.5	60	1.047	6
0.8	45.84	4.0	70	1.222	7
0.9	51.57	4.5	80	1.396	8
1.0	57.296	5.0	90	1.5708	9
1.1	63.03	5.5	100	1.745	10
1.2	68.75	6.0			
1.3	74.48	6.5			
1.4	80.21	7.0			
1.5	85.94	7.5			
1.6	91.67	8.0			
1.7	97.40	8.5			

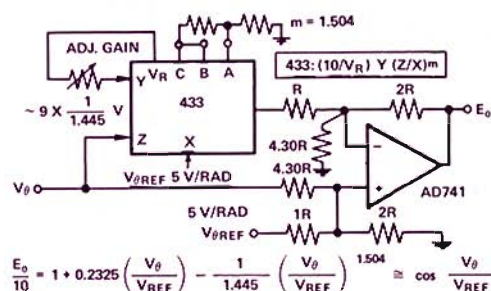

Figure 3. Basic Circuit for Approximating  $\cos \theta$



## COS $\theta$

For approximating  $\cos \theta$  to reasonable accuracy, two terms are inadequate. However, by using arbitrary exponents and a linear third term, we can get a better-than-1% approximation using only a single power term. Again, the function can be embodied with a single 433 and a single op amp. A reasonably close approximation\* is

$$\cos \theta \cong 1 + 0.2325 \theta - \frac{\theta^{1.504}}{1.445} \quad (3)$$

A circuit and a plot of the theoretical errors can be found in Figures 3 and 4.

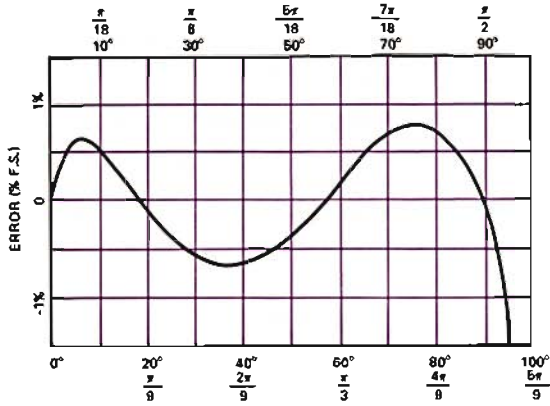

Figure 4. Theoretical Errors of  $\cos \theta$  Approximation (% F.S.)

## TAN<sup>-1</sup> ( $V_B/V_A$ )

The arctangent is inherently one of the most difficult functions to fit because of the wide dynamic range that the input ratio ideally must cover. "Building-block" approximations generally have limited feasibility because the ratio must appear explicitly as the result of a division.

Yet the function is useful: it provides the angular information in the transformation  $R = \sqrt{V_A^2 + V_B^2}$ ,  $\theta = \tan^{-1} (V_B/V_A)$ . We have already seen (p. 3) how to obtain  $R$  efficiently.

It yields under the combined assault of

1. The 433, used to obtain a non-integral exponent
2. Feedback techniques to obtain an equation which is an implicit solution for  $V_\theta$  (to a very good approximation)
3. The 433's ability to convert a widely-ranging ratio into a harmless difference of logarithms in its internal workings, without explicitly obtaining the ratio
4. Ever-present Mother Nature, who is always ready to help us, if only we will listen!

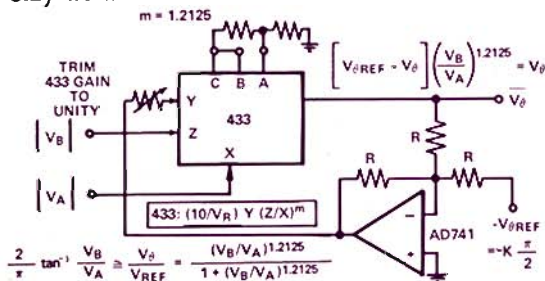

Figure 5. Basic Circuit for Approximating the Arctangent of a Ratio.

\*A more-accurate one (using 2 op amps) is

$$\cos \theta = \sin \left[ \frac{\pi}{2} - \theta \right] \cong \left[ \frac{\pi}{2} - \theta \right] - \frac{1}{6.28} \left[ \frac{\pi}{2} - \theta \right]^{2.827} \quad (3a)$$

A circuit that embodies the approximation is shown in Figure 5. The theoretical errors are plotted in Figure 6. The equation fundamentally provided by the scheme is

$$\theta = 90^\circ \frac{W^{1.2125}}{1 + W^{1.2125}} \cong \tan^{-1} W \quad (4)$$

where  $W = V_B/V_A$

The circuit solves the implicit equation

$$\theta = \left[ \frac{\pi}{2} - \theta \right] \left[ \frac{V_B}{V_A} \right]^{1.2125} \quad (5)$$

with a maximum theoretical error less than  $0.75\% \frac{\pi}{2}$  (or  $0.68^\circ$ ).

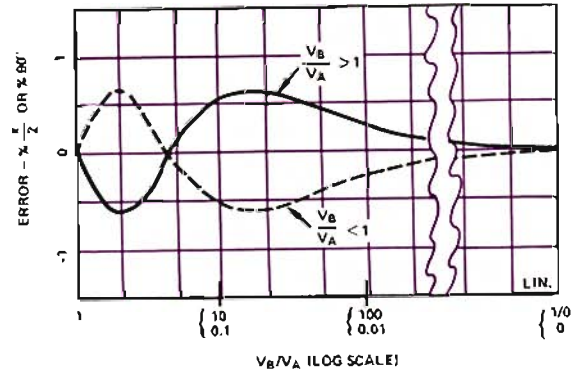

Figure 6. Theoretical Errors of Arctan Approximation

## PRACTICAL CONSIDERATIONS

The numbers presented above have all been worked out to about 4 places to determine the limits of performance with ideal circuitry. However, since performance depends critically on the analog circuit elements, care must be observed to take into account component tolerances, and provide "tweaks" for an empirical fit. In the case of the arctangent approximation, care may be necessary to avoid oscillation at large values of the ratio. Large values of feedback capacitance around the amplifier will be helpful, but will slow the circuit's response.

## TABULAR DATA

The table presents ideal and approximate values of the functions discussed above, for the typical coefficient values listed. Although there may be coefficient values that would give somewhat better fit, they are perhaps best determined empirically, in view of the tolerances of the 433 and the resistor ratios. The table will help in such empirical determinations.

$\theta^\circ$	$\sin \theta$		$\cos \theta$		$W$	$\tan^{-1} W$		
	Ideal	Approx.	Ideal	Approx.		Ideal <sup>o</sup>	Ideal (r)	Approx.
0	0.	0.	1.	1.	100	89.43	1.5608	1.5649
10	0.1736	0.1734	0.9848	0.9905	30	88.09	1.5375	1.5458
20	0.3420	0.3409	0.9397	0.9390	10	84.29	1.4711	1.4801
30	0.5	0.4980	0.8660	0.8602	3	71.57	1.2490	1.2428
40	0.6428	0.6405	0.7660	0.7591	1	45.	0.7854	0.7854
50	0.7660	0.7643	0.6428	0.6389	0.5	26.57	0.4636	0.4735
60	0.8660	0.8658	0.5	0.5016	0.2	11.31	0.1974	0.1954
70	0.9397	0.9412	0.3420	0.3485	0.1	5.71	0.0997	0.0907
80	0.9848	0.9871	0.1736	0.1810	0.05	2.86	0.05	0.0405
90	1.	1.	0.	0.	0.	0.	0.	0.

## GATE RESPONSES SIMPLIFIED

### A GUIDE FOR THE OCCASIONAL USER OF LOGIC

If you're an experienced logic circuit designer, an expert on Boolean logic, or a recent graduate, the chances are that you'll find this discussion elementary and somewhat obvious.

If, on the other hand, you've spent a good part of a long and productive lifetime with analog circuitry or other matters, and have had only occasionally to reason out the expected behavior of a circuit diagram that contains logic gates, you may wonder why no one has bothered to provide this sort of discussion before.

One will recognize the two basic gate forms in the table below: "AND" with straight-backed input and rounded output, and "OR" with concave input and sharp output. One will also recognize the small circles that indicate "negation," i.e., reversal of logic polarity of the signal appearing at an input or output. And finally, consider that this discussion applies to "positive true" logic, i.e., "0" implies a voltage near ground potential (less than 0.8V for TTL inputs), and "1" implies a positive voltage (greater than 2.0V for TTL inputs).

The key that unlocks the ability to interpret these diagrams (or choose the correct one) quickly is to observe that each diagram goes with an easily recognized statement, such as "All 1's give 1" (AND), "Any 1's give 0" (NOR). This is done by reading direct inputs or outputs as "1" and negated inputs or outputs as zero (think of the circle as a "0"), and the relationship as either *all* (AND form) or *any* (OR form).

Any function that is provided by one form of gate can be identically provided with the other form by complementing all input and output markings. Thus the "OR" equivalent to the "AND" gate will still have the response "All 1's give 1,"

but will in addition indicate that the statement "Any 0's give 0" is identical. The equivalent forms are logically derived by "De Morgan's Theorem," but the beauty of this approach is that you don't have to write a logic equation to know what a gate will do, nor do you have to memorize anything further. Just be sure that the person who draws the diagram and the reader of it are both using positive-true logic.

#### MIXED INPUTS, COMPLEMENTARY LOGIC, REALIZABILITY

If a gate has both negated and direct inputs, like so,

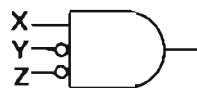

its function can be read in the same way, applying "all as indicated" for AND gates and "any as indicated" for OR gates. Thus, if X is 1 and Y and Z are 0, the output will be 1. The equivalent statement is: if X is 0, or Y or Z is 1, the output will be 0.

The indicated function must be understood to work independently of the polarity convention for the logic signals. That is, if complementary (i.e., negative true) logic is used for any of the applied signals, it should be inverted; otherwise confusion may arise.

Any of the logic functions indicated on the table can be performed using "NAND" or "NOR" gates only, by using the equivalent functions and additional gates to perform the indicated inversions. ▶▶▶

	DIRECT FUNCTION	EQUIVALENT (DEMORGAN'S THEOREM)	RESPONSE		
			ALL 0'S 000...0	0'S AND 1'S 011...01	ALL 1'S 111...1
"AND"	 $X \cdot Y \cdot Z$ ALL 1'S GIVE 1	 $\overline{X \cdot Y \cdot Z}$ ANY ZERO'S GIVE 0	0	0	1
"NAND"	 $\overline{X \cdot Y \cdot Z}$ ALL 1'S GIVE 0	 $X \cdot Y \cdot Z$ ANY ZERO'S GIVE 1	1	1	0
"OR"	 $X + Y + Z$ ANY 1'S GIVE 1	 $\overline{X + Y + Z}$ ALL ZERO'S GIVE 0	0	1	1
"NOR"	 $\overline{X + Y + Z}$ ANY 1'S GIVE 0	 $X + Y + Z$ ALL ZERO'S GIVE 1	1	0	0
EXCLUSIVE OR	 $X\overline{Y} + \overline{X}Y$ BOTH 1'S OR 0'S GIVE 0	 DIFFERENT INPUTS GIVE 1	0	1	0

BASIC LOGIC GATES, POSITIVE - TRUE LOGIC

## TWO DIGITAL PANEL METERS 4½-DIGIT AD2004 HAS FLOATING INPUT, LED DISPLAY

The AD2004\* is a high-performance, 4½ digit ( $\pm 1.9999V$ ) digital panel meter with an easy-to-read light-emitting-diode display. Requiring only a standard 5V supply, it has a floating optically-isolated analog section that can withstand common-mode voltages greater than  $\pm 300V$  and provides common-mode rejection of 120dB. Normal-mode noise at line frequency (and its harmonics) is reduced by 60dB.

Maximum error is  $\pm 0.01\%$  of reading  $\pm 1$  digit, resolution is  $\pm 0.1mV$ , and temperature coefficient is  $\pm 15ppm/^{\circ}C$ . Polarity and zero are both automatically established, and the operating temperature range is  $0^{\circ}$  to  $+60^{\circ}C$ .

The conversion rate is normally 4/second, but an external trigger may be applied to obtain other rates. Readings may be held upon application of an external command. During conversion, the previous reading is held by latched logic; the logic outputs include the BCD number, the "overrange" digit, the polarity, and an overload signal. A "status" signal indicates completion of each conversion. The display flashes 4 zeroes to indicate overload.

Physically, the AD2004 is housed in the same convenient "snap-in" format that is used for the AD2002 and AD2003 panel meters (3"W x 1.8"H), but it is slightly deeper behind the panel (2.5"). Mounting of the AD2004 in its panel cutout is tool-free. The lightweight aluminum case provides electrical shielding, thermal baffling, structural strength, and dissipation of heat by conduction and radiation.

The displayed decimal point location is programmable by the user. The red filter used with the bright red LED's can be easily silk-screened by the user with physical units, functional information, and his own logo and part number.

### APPLICATIONS

The AD2004 is useful both as a high-accuracy panel meter and as an input for

data-processing systems. Metering applications made possible by its high resolution include monitoring of small voltage changes at any level (e.g., battery discharge), measuring voltage accurately at any level, and obtaining voltage information over a wide dynamic range without rescaling.

Its floating input allows measurement of differential voltage at any level within its 300V common-mode rating. Current measurements via resistive shunts are a natural area of application.

Finally, any of the above kinds of measurement, manifested both as digital signals and a visual readout, may be interfaced directly with a digital computer, storage facility, or data link. ▶▶▶

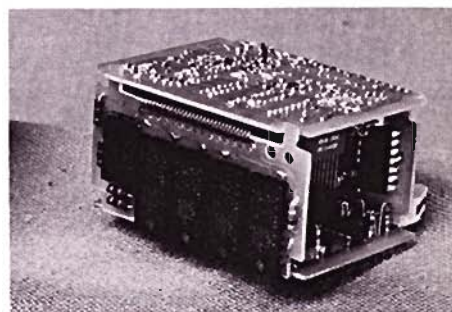
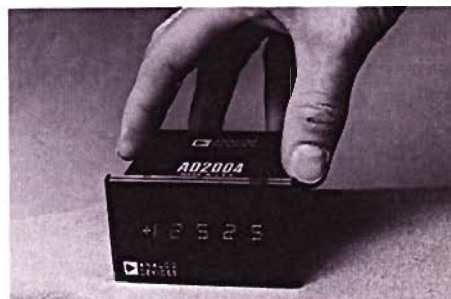

## 3½-DIGIT UNIT HAS DIFFERENTIAL INPUT PRICE IS ONLY \$93 IN 100'S

Model AD2003\* is a 5V-powered digital panel meter offering high performance at low cost. Its 80dB of common-mode rejection (@  $\pm 2.5V$ ), obtained with an instrumentation amplifier, allows accurate measurements to be made in single-ended systems where the "ground" is of doubtful quality. Normal-mode rejection of 40dB greatly reduces errors caused by noise at line frequency and its harmonics.

The AD2003 provides accurate (0.05% of reading  $\pm 1$  digit) and stable ( $\pm 50ppm/^{\circ}C$ ) readings of bipolar differential-input signals over a full-scale range of 0 to  $\pm 199.9mV$ , with automatic overload and polarity indication, and no zero drift.

The fully-latched logic provides a flickerless display via green-filtered bright Numitrons. (Red, amber, and blue filters are optionally available.) Decimal point location is programmable; an all-segment filament test input is provided; and overload is indicated by an entirely unambiguous set of 3 dashes: - - -

The internally-generated display rate is 5/second; with external drive, rates up to 16/second, or down to zero (hold) are available.

Like the AD2002 and AD2004, the AD2003 is housed in a rugged aluminum "snap-in" case. The overall dimensions are 3"W x 1.8"H x 2"D. Availability is from stock. Price is \$140 (1-9), decreasing to \$93 in 100's. ▶▶▶

### CORRECTION

In Volume 6, No. 2, page 9, introducing the 2½ digit AD2002\* DPM (\$50 in 100's, available from stock), we showed a low-cost 5V temperature-monitoring circuit. Unfortunately, 3 NPN transistors were portrayed as PNP's. Correction herewith:

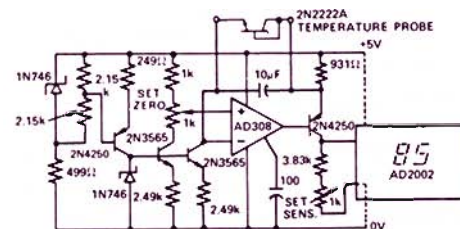

\*For information on the AD2004, use the reply card. Request H5. Price is \$269 (1-9) and \$189 in 100's.

\*For information on the AD2003, request H6.

\*For data on the AD2002, request H21.



## MODULAR MULTIPLIER, OP AMP, POWER SUPPLY

### 10 MHz MULTIPLIER/DIVIDER HAS <0.5% DC ERROR (INTERNALLY TRIMMED)

Model 429B\* has performance that is excellent, across-the-board, starting with less than 0.5% of-F.S. error at DC, less than 0.5% vector error over the entire audio spectrum (1% max at 50kHz), less than 1% amplitude error at 300kHz, and within 3dB well up into the video region (to 10MHz, see Figure 1). Furthermore, the 1° differential phase shift at 1MHz means that the dc component of output maintains its accuracy for input frequencies of the order of 1MHz, a desirable feature for accurate RMS and power measurement and correlations.

Pretrimming insures that the 0.5% DC specification is available with no user adjustments. On the other hand, the 0.2% maximum nonlinearity specification permits the user to obtain errors less than 0.3% by the use of external trims. Also, since nonlinearity decreases with signal level,  $[\Delta(XY) \cong X\Delta Y + Y\Delta X]$ , the actual error at low signal levels can be trimmed to represent a considerably smaller than specified fraction of F.S.

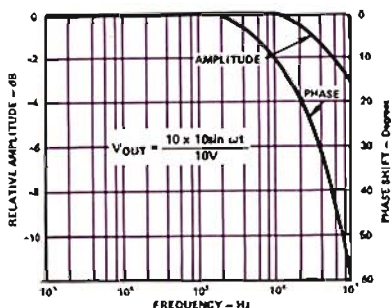

Figure 1. Amplitude and Phase vs. Frequency

Variations with temperature are small, too. Scale-factor drift is less than 0.02%/°C, offset drift is less than 1mV/°C, and maximum error drifts less than 0.04%F.S./°C. Feedthrough errors are small: X feedthrough (X maximum, Y = 0) is 30mVp-p, Y feedthrough (Y maximum, X = 0) is 20mVp-p, and they can be reduced by external trims.

### DIVIDER AND SQUARE ROOTER

One important application for multipliers having the combination of low dc errors, \*For information on the 429A and 429B, use the reply card. Request H7.

wide bandwidth, and low noise, is in moderately-wideband 2-quadrant divider and square-root circuits. The 429 can be used as a divider with no external circuit elements (but optional trimming pays big dividends) by the use of a feedback connection. As a matter of well-known fact, errors increase in inverse proportion to denominator voltage. If they are small to begin with, as they are in 429B, the denominator is capable of a considerably wider useful dynamic range than is often the case. As a divider, the 429B is typically capable of <1% error with a denominator range of -1 to -10V, and will maintain <5% error from -0.2V to -10V.

The Model 429 data sheet discusses these principles in considerable detail; it should be of interest to anyone interested in applying multipliers as dividers. Figure 2 shows the typical errors of the 429 in the divide mode. For equal numerator and denominator, the deviation from the ideal 10V output is plotted vertically vs. the denominator input magnitude.

### APPLICATIONS

Typical applications of the 429 include fast division, modulation and demodulation, phase detection, instrumentation calculations, analog computing, adaptive process control, and trigonometric computations.

Physically, the 429B is 1.5 inches square and 0.62" high. The low-cost version, the 429A, has a similar temperature range for rated performance (-25°C to +85°C), and about twice as much error. Cost is \$139 (B) and \$109 (A), 1-9; \$129 and \$104 (10-24); and less for greater quantity. ▶▶

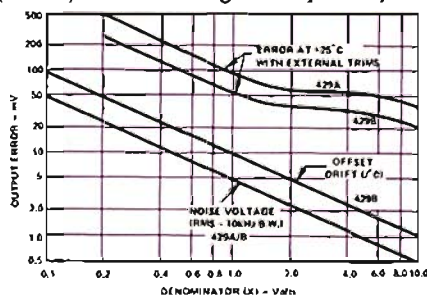

Figure 2. Errors of Model 429 as a Divider, for  $10(Z/X) = 10V$

### 920 POWER SUPPLY: ±15VDC @ ±200 mA

The Model 920 Power Supply\* is a dual supply that is pin-compatible with Models 902, 904, and 915. It has comparable performance specifications, except for considerably greater power output: 200mA fully loaded.

With its regulation of 0.05% max against line variations and 0.1% max vs. load, temperature coefficient of 0.015%/°C max, and initial output between 15.000 and 15.3V, it is entirely suitable for powering systems containing op amps, function modules, and conversion devices.

It is short-circuit protected by a current-limiting scheme that limits short-circuit current, thus reducing internal power dissipation and temperature rise. This protects both the module and the external circuitry and fosters increased reliability.

Its dimensions are 3½" x 2½" x 1¼"; it weighs 18oz seated; price is \$69 (1-9). ▶▶

### PERFORMANCE PRICE = VALUE MAXIMIZED IN FET OP AMP

Model 43† is an amplifier having low max bias current (10pA), initial offset (1mV, adjustable to zero), and offset drift (5μV/°C:43K and 20μV/°C:43J).

Noise is 2μVp-p (0.01 - 1Hz) and 2μVrms in a 40kHz bandwidth. CMR is 80dB min (±10V for 43J, +5, -10V for 43K).

Gain is 50,000 at rated load of 5mA; small-signal gain-bandwidth is 4MHz, and full power output is available to 100kHz (minimum slewing rate is 6V/μs).

The excellent drift, noise, and bias-current characteristics make the 43K worth looking at for low-level signal-handling in either the inverting, the non-inverting, or the differential mode. It is a first choice because of its small size (1" x 1" x 0.5") and low price (\$20:43J, \$26:43K, 1-9). ▶

\* For further information on Model 920, use the reply card. Request H8.

† For information on Models 43J & K request H9.



## MODULES ARE AT HOME IN CONVERTER MANIFOLD BOARDS FOR \$75, SUBSYSTEM ASSEMBLY IS SIMPLIFIED

The AC1510 and AC1511 Manifold Boards\* allow the busy system designer to steer an economical middle course between laborious design of all the minutiae of a system in-house and the high expense of "farming out" portions of a system for custom design and assembly.

The boards contain sockets for standard separately-purchased Analog Devices plug-in modules. Also included are the associated wiring, adjustment pots, and such necessary amenities as power-supply bypass capacitors.

The AC1510 Conversion Subsystem board accepts an 8-, 10-, or 12-bit A/D converter (e.g., ADC-12QU), a sample-hold module (Model SHA-1A), and an 8-channel multiplexer (MPX-8A). For per-channel conversion, the multiplexer may be omitted; for slowly varying signals, the sample-hold may be omitted. For more than 8 channels, the outputs of 1 or more AC1511 Multiplex Extenders (or other external multiplexers) may be applied as inputs for 2-level multiplexing; alternatively, an additional 8 channels of single-level multiplexing can be made available with an external MPX-8A.

The AC1511 Multiplex Extender accepts up to 4 MPX-8A's, hence up to 32 channels of analog input. Each AC1511 accepts a Model 47 amplifier, which may be used for buffering and 1-5-gain. (Buffering is recommended to reduce crosstalk and capacitive loading.) 8 AC1511's can extend system capacity to 256 channels.

### THE DESIGNER'S POINT OF VIEW

The Manifold Boards described here are designed for use in "high-level" portions of a system. This means that the inputs, whatever their source or nature, have been conditioned and scaled to the normalized input level of the converter (usually 10V), and are single-ended.

The rationale should be obvious: the front-end design is entirely determined by the nature of the inputs and is unique, not only to the system, but to the envi-

\*For information on the Manifold Boards, use the reply card. Request H10.

ronment in which it is to be used. This is the most-challenging part of the design, in most cases. The high-level portion of the system is in some respects routine, but tedious, and the cost savings inherent in the use of a prewired (and engineered) Manifold Board are obvious, especially at \$75 per board.

The same considerations that motivate a designer to use modular system elements should motivate him to mount them in a standard receptacle: avoidance of spending costly design, board layout, drafting, assembly, and debugging, on a nearly-standard but one-of-a-kind part of his system. (Meanwhile, this effort may distract his attention from the more-significant problems that may lurk in the transducer and signal-conditioning part of the system, where his attention is really needed.)

### ADAPTABILITY

The user has only to supply  $\pm 15V$  and +5V power, normalized analog input signals, a convert command, and channel-address logic. Each channel is addressed with a random-access binary number of up to 8 bits, depending on the number of channels in the system. The analog-to-digital converter's data and status outputs are the system's only outputs.

Not only is the system wiring greatly simplified, the hardware problems are also greatly reduced. Each of the cards, measuring 4.5" x 6.0", can be readily plugged into a standard card rack, such as the H. H. Smith Model 3050 Universal Card Rack.

The edge connectors that mate with the AC1510 and AC1511 Manifold Boards are included in the price of the board. All the cards required for a 256-channel system would occupy less than half the available space in the card rack. The card rack itself can be easily mounted in a standard 19" equipment rack.

Analog's broad line of power supplies provides an ideal selection for use in powering the data-acquisition subsystems.

## AC1510 CONVERSION SUBSYSTEM

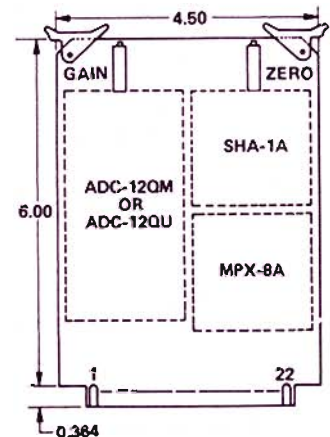

ASSEMBLY BLOCK DIAGRAM

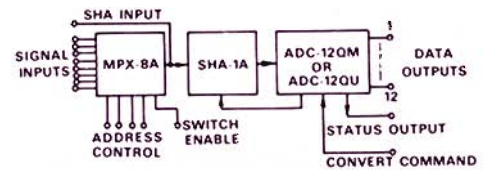

## AC1511 MULTIPLEX EXTENDER

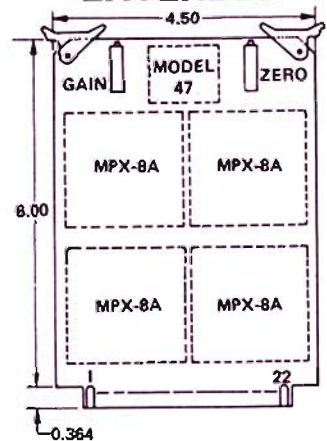

ASSEMBLY BLOCK DIAGRAM

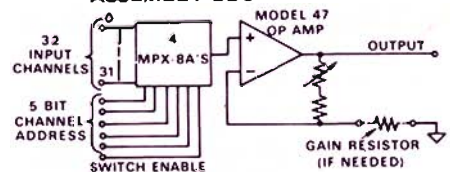

### \*NOTES:

1. Module locations shown with dotted lines. Modules are not included in purchase price of board.
2. With modules plugged in maximum height of components above surface of board is 0.44".
3. Boards mate with Cinch 251-22-30-160 socket (supplied).
4. Outline dimensions: Inches.



## MONOLITHIC ANALOG MULTIPLIER-DIVIDERS

### NEW AD531 COMPUTES $XY/Z$ ; TRUE OUTPUT POLARITY FOR $\pm X, \pm Y$

The AD531 is a monolithic integrated circuit that computes the function  $XY/Z$ , with any or all of the three inputs variable. Like the Model 433 (Vol. 6 No. 2), it can be used for multiplication, division, squaring, square-rooting, rms and vector computation. The AD531 has the further advantage that X and Y are not inherently restricted as to polarity, a great increase in versatility that also adds one more function—absolute value—to its bag of tricks.

The circuit of the AD531 evolved from that of the AD530. It combines a differential-input transconductance multiplying element, stable reference, and output amplifier on a single monolithic chip. Unlike the AD530 ( $XY/10$ ), which has a fixed nominal scale factor, the AD531 permits an adjustable or variable scale factor ( $1/Z$ ) for increased operational flexibility. The denominator can be set to a fixed value by connecting a resistance of appropriate value between the internal reference voltage and the reference input. It can also be varied dynamically by applying an externally-controlled reference current.

Another interesting feature of the AD531 is its differential X input. It may be used in instrumentation or AGC applications to reject common-mode interference, or wherever two input signals must be subtracted before being subjected to further processing (multiplication and/or division).

Linearity of the AD531 is excellent. With a few minor external adjustments, it easily achieves the specified overall performance: guaranteed maximum error of  $\pm 0.5\%$  (L),

for  $XY/10$ . The built-in output amplifier provides a full  $\pm 10V$ , 5mA output swing.

Dynamic performance is excellent, with small-signal bandwidth of 1MHz and slew rate of 45V/ $\mu$ s.

The AD531, housed in a hermetically-sealed 14-pin ceramic dual in-line package, is expected to be available in prototype quantities in October. Prices for the J, K, L, S versions are \$30, \$45, \$54, and \$60 for 1-24 units. ▶▶▶

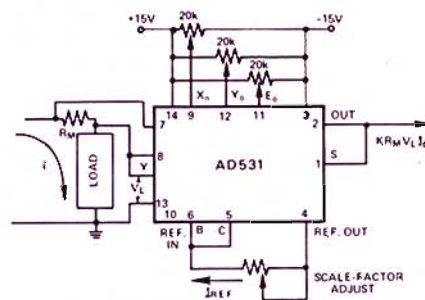

Instantaneous Wattmeter Application (Using Differential Input)

$$E_O = W = KV_L I_L R_M$$

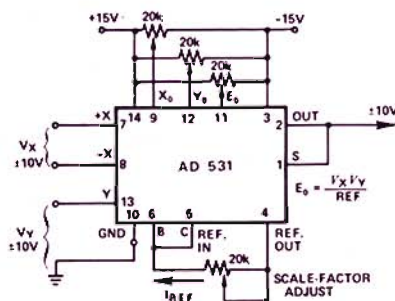

Adjustable-Scale-Factor Multiplier

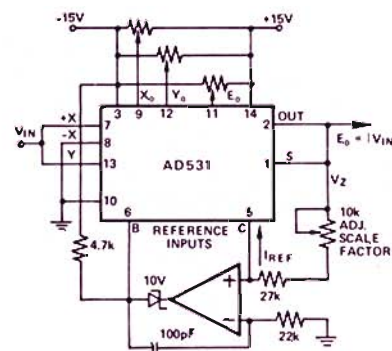

Absolute-Value Circuit

## TWO NEW AD530 VERSIONS: AD530L (0.5% MAX. ERROR), AD530S/883

The first-in-the-industry AD530\* monolithic Multiplier/Divider has met with wide acceptance and that sincerest of all forms of flattery: imitation (i.e., "second-sourcing"). Now, a combination of manufacturing maturity and repeatedly-expressed user requirements have caused two new variations to be evolved:

**AD530L** is a more-tightly-specified version with guaranteed maximum error of 0.5% at +25°C, 1.5% from 0 to +70°C, thus making it the highest-accuracy and most temperature-stable IC multiplier currently available. The top-of-the-line of the AD530 family, the "L" may be considered a harbinger of a totally new generation of even more accurate IC multipliers now under development at Analog Devices.

The **AD530S/883** type number designates an AD530S wide-temperature-range (maximum error now <3%, -55°C to +125°C)

unit that has been processed to meet the screening requirements of MIL-STD-883, Method 5004, Class B.

This specification requires that all devices receive special pre-cap visual inspection, fine and gross leak-testing, temperature cycling, centrifuge, high-temperature storage, and operating burn-in for one week at +125°C.

The AD530S had been available for some time with 883 screening to special order, but at a relatively-high price made necessary by the amortization of processing charges on a lot basis, and with relatively-long delivery. The availability now of the AD530S/883 means that the product is available with short delivery time (generally from stock) and at lower prices (\$63, 1-24, decreasing to \$42 in 100's). ▶▶▶

\*For information on the AD530, including application notes, request H12. For AD530L, request H13. For AD530S/883, request H14.

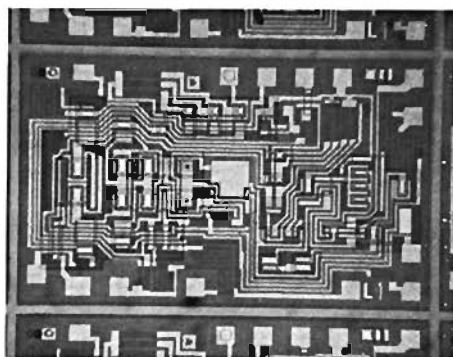

\*For complete information on the AD531, use the reply card. Request H11.



## TWO DUAL TRANSISTORS AND A DUAL TRAK-FET

### SUPER- $\beta$ DUAL HAS $h_{FE} > 2000, V_{CE0} > 20V$

It is a cliché of "conventional wisdom" that super- $\beta$  transistors are "punch-through" devices that have very low voltage ratings. As living proof to the contrary, the AD814, 815, and 816\* offer minimum current gains of 1000 and 2000 (definitely in the super- $\beta$  class!) at voltage ratings of 35, 20 & 10V, and prices of \$4, \$5.50, & \$4.60 in 100's.

Besides their excellent current gain, the monolithic matching allows offset voltage specs of 1mV and  $5\mu V/^\circ C$  (both *max*) and  $I_{B1} - I_{B2}$  less than 0.5nA (815 & 816) at  $I_C = 10\mu A$  and  $V_{CEB} = 5V$ .

Matched dual transistors are used as input stages of op amps and other instrumentation circuits that need low drift. The 814's have lower bias currents than ordinary transistors, lower drift and noise than Darlington, and they are easier to use than FET's in low-drift applications. (Their bias current is also better-behaved at high temperatures.)

### AD530D: MULTIPLIER IN A DIL PACKAGE

All versions of the AD530 (J, K, L, S), Analog's popular multiplier-divider-squarer-square rooter, are now available in the convenient and easy-to-use hermetically-sealed dual in-line ceramic package.† (Specify "D" suffix.)

The pin configuration is like that of the AD531 (for the applicable terminals) and will be the standard for future MDSSR's from ADI (and probably others in the industry) in times to come.

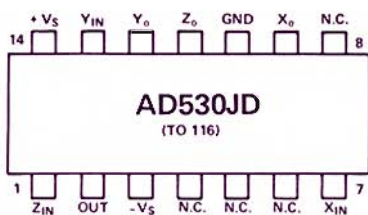

\*For further information on the AD814 family of monolithic duals, use the reply card. Request H16.

†For information on "D" versions of the AD530, use the reply card. Request H15.

### MONOLITHIC DUAL FET'S HAVE LOW DRIFT AND NOISE

The AD840 and 841\* are large-geometry dual field-effect transistors characterized by low offset (5mV max) and drift (5 and  $10\mu V/^\circ C$  max) and unusually low noise,  $15nV/\sqrt{Hz}$  max (@ 10Hz).

The specifications of all Analog Devices TRAK-FET's include TDN (temperature-drift nonlinearity)†, which defines the worst-case limits of "tweakability" to minimize drift. TDN for both types is typically  $1\mu V/^\circ C$ , max  $3\mu V/^\circ C$ . A TDN calculation is superimposed on the typical drift curve below.

Maximum gate current is 50pA, transconductance of  $500\mu mho$  min has mismatch of 0.6% typical, 3% maximum; output conductance of  $1\mu mho$  max has maximum differential of  $0.1\mu mho$ .

The AD840-1 performance is near-ideal for op-amp and instrumentation-circuitry differential-input circuits. In linearity, thermal tracking, and recovery time from thermal transients, they are vastly better than 2-chip hybrids; the diffusion-isolated elements require no special bulk biasing, as is necessary for some interdigitated monolithic dual-FET types. Cost is only \$9.40/\$7.80 (1-99) for AD840/AD841.

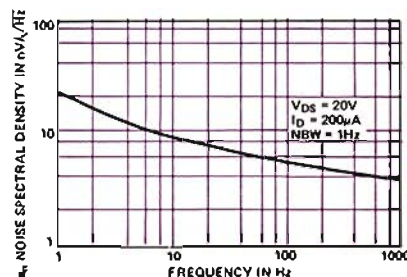
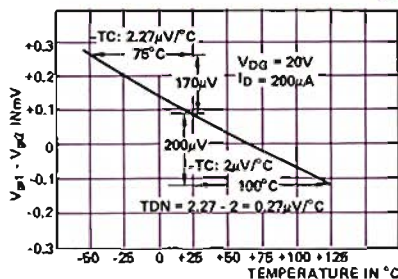

\*For complete information on the AD840-1 request H17.

†See *Dialogue*, Vol. 6, No. 1 for a definition and interpretation of TDN.

### MONOLITHIC AD818 HAS EXCELLENT LOG CONFORMITY

The AD818\* is a dual NPN transistor designed specifically for logarithmic computing applications. Its low value of  $r_e$  tracking error ( $1\Omega$  at  $I_C$  up to 3mA) results in 8 decades of excellent log conformance.

Its low  $V_{sat}$  at high values of current and low  $C_{ob}$  make it an excellent input stage for wideband amplifiers.

Here is a simple square-root circuit that can use two AD818's and two low-cost op amps. It takes the log of the input, divides by 2, then takes the antilog. The current source  $I_R$  sets the scale factor.

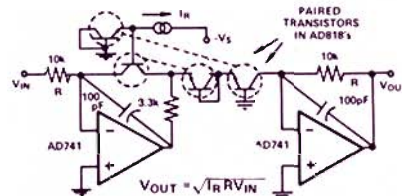

SQUARE-ROOT CIRCUIT

### AD540 FET-INPUT OP AMP A "BEST BUY" @ \$4.90 (100'S)

The AD540J† is perhaps the only available op amp, at its price, that provides its unique combination of low bias currents, high overall performance, and accurately-specified predictable operation.

Maximum bias current is 50pA, minimum gain is 20,000, minimum CMR is 70dB ( $\pm 10V$ ), slew rate is  $6V/\mu s$ .

The AD540J keeps many of the features of ADI's more costly FET-input types:

- Published offset voltage and bias current specs are valid for fully warmed-up units. (Conventional high-speed IC testing does not allow warmup time or account for spec changes due to internal temperature rise.)
- Bias current is max for *either* input, not average of both.
- Voltage nulling of AD540J has little effect on thermal drift.

\*For information on the AD818, request H18.

†For the whole story on the AD540J, request H19.

# This is what you have to know to know everything about converters.

## Table of Contents

Analog-Digital Conversion Handbook

### I. Converters at Work

Data-System Components  
Data Acquisition & Distribution  
Circuit Traces with Components

### II. Applications of Converter Systems

Automatic Testing  
Communications and Signal Analysis  
Displays  
Commerce and Industry

### III. Converters

Understanding Converters  
Converter Design & Testing  
Specifying & Applying Converters Successfully

### IV. System Accessories

Operational Amplifiers  
Instrumentation Amplifiers  
Multiplexers  
Sample-Holds

### V. What To Do When Things Don't Seem To Work Right

Basic Questions People Always Ask  
and Where to Find the Answers  
The 10 Mistakes Users Most Commonly Make  
If All Else Fails

### Appendix

Glossary & Definitions  
Some Useful Tables

## Analog-Digital Conversion Handbook 400 pages. \$3.95

Since you make more kinds of A-D and D-A converters than anyone else, I wouldn't pass up your handbook for anything. Enclosed is my check for \$\_\_\_\_\_ for \_\_\_\_\_ copies.

Name \_\_\_\_\_ Title \_\_\_\_\_

Company \_\_\_\_\_ Street \_\_\_\_\_

City \_\_\_\_\_ State \_\_\_\_\_ Zip \_\_\_\_\_

Please allow 4-6 weeks for delivery.

Mail to: Analog Devices, Inc., Box 796, Norwood, Mass. 02062



- If you are averse to mutilating your copy of *Analog Dialogue*, you may either
1. Make a copy of the coupon, complete it, and send it with your check for \$3.95 per copy, or
  2. Write the words "Bill me \$\_\_\_\_\_ for \_\_\_\_\_ copies @ \$3.95," accompanied by your initials, on the reply card. An invoice will accompany your book(s).