

analog dialogue

A forum for the exchange of circuits and systems for measurement, control, and test

SINGLE-BOARD MEASUREMENT-AND-CONTROL SYSTEM (Page 3)

8-Bit, 8-Channel DAS Stores Results in On-Chip RAM

High-Accuracy, Stable 10V References

Complete contents on page 3

**DIRECT CONNECTION
TO 4-20mA
TRANSMITTER SIGNALS**

**DIRECT CONNECTION
TO mV SIGNALS**

**DIRECT CONNECTION
TO THERMOCOUPLES**

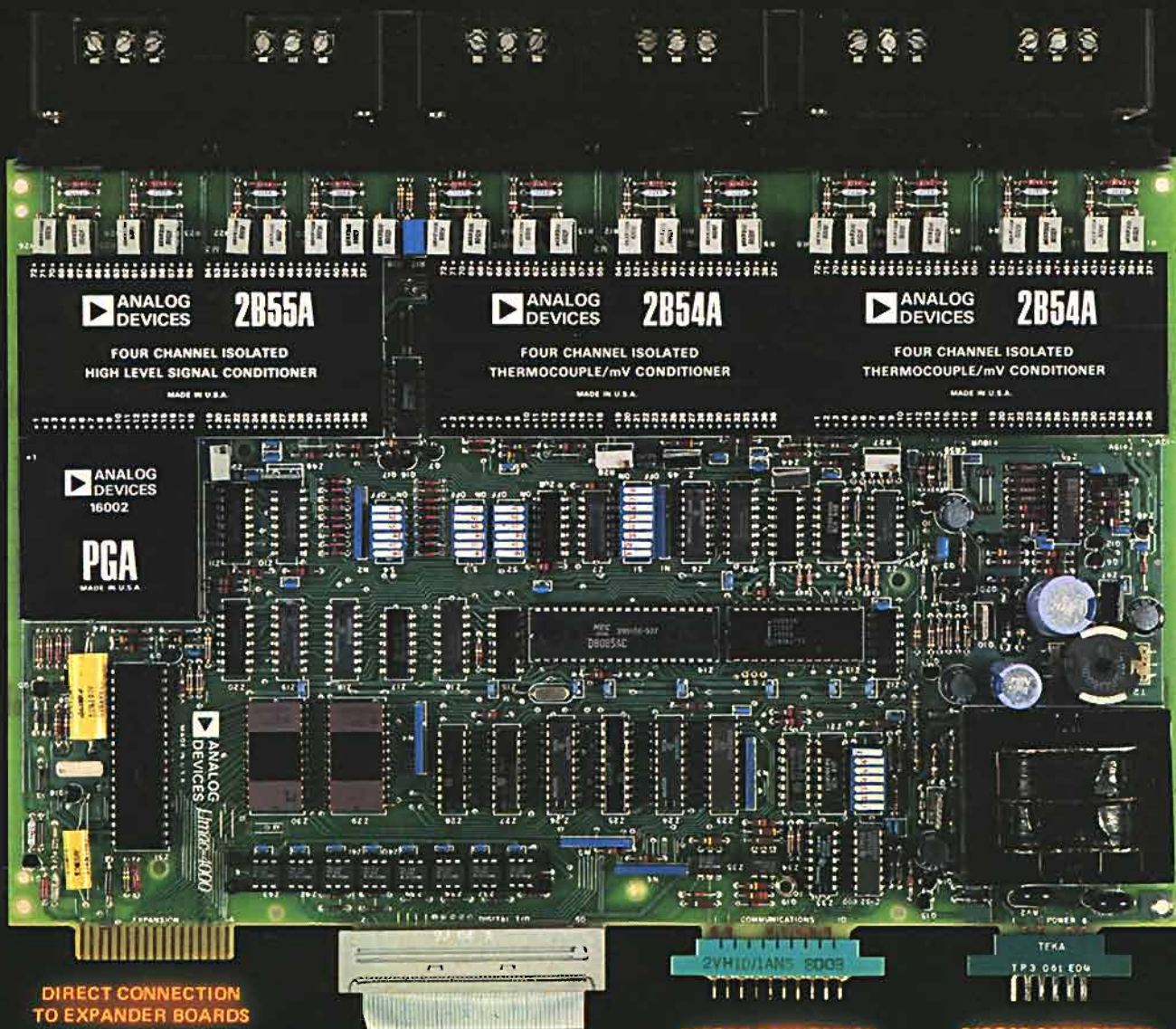

**DIRECT CONNECTION
TO EXPANDER BOARDS**

**DIRECT CONNECTION
TO SOLID STATE RELAYS
AND CONTACT CLOSURES**

**DIRECT CONNECTION
TO ANY HOST
COMPUTER**

**DIRECT CONNECTION
TO AC LINE OR
+24V SUPPLY**

**ANALOG
DEVICES**

Editor's Notes

WAXING HISTORICAL

These words are written in the waning hours of 1980; for our remote outposts, it is already 1981, a year which will mark the 15th year of publication of this journal, and the 13th year of our stewardship. While adding a copy of the last 1980 issue to our bulging binder, we nostalgically turned the pages of issues long forgotten. The amount of technological progress reported in them surprised even us. Before the list expands beyond the capacity of this column, we thought you might be interested in seeing a roll of just the cover stories alone, though much significant progress never made the cover, e.g., isolators, signal conditioners, and the AD580 bandgap reference; and a (remarkably) few cover products even bombed! Here they all are, without fear or favor:



- 1967 1-1. *Analog Computation with Magneto-Resistance Multipliers**
1-2. *Gas Chromatograph Uses Varactor-Bridge Amplifier**
1-3. *User's Guide to Measuring Op-Amp Specifications**
- 1968 2-1. *Chopper Amplifier's Stability in Electron Microscope**
- 1969 3-1. *Noise and Operational Amplifier Circuits*
- 1970 4-1. *Settling Time of Operational Amplifiers**
4-2. *High-Performance IC FEET-Input Op Amp (AD503)**
- 1971 5-1. *A Complete Monolithic Multiplier-Divider (AD530)**
5-2. *Monolithic Switches for 12-Bit MDACs (AD555)**
5-3. *Monolithic Op Amp with $1\mu V/^\circ C$ Drift (AD504)*
5-4. *Monolithic Op Amp Has $130V/\mu s$ Slewing Rate (AD505)*
5-5. *Low-Cost Digital Panel Meter Has $3\frac{1}{2}$ Digits (AD2001)*
- 1972 6-1. *Monolithic Differential Instrumentation Amp (AD520)*
6-2. *$Y(Z/X)^m$ at Low Cost (Model 433)*
6-3. *New $3\frac{1}{2}$ and $4\frac{1}{2}$ Digit DPMs (AD2003 and AD2004)*
- 1973 7-1. *Slim, Low-Cost $3\frac{1}{2}$ DPM (AD2010)*
7-2. *SERDEX SERIAL Data-EXchange Modules**
- 1974 8-1. *10-Bit Monolithic CMOS D/A Converter (AD7520)**
8-2. *12-Bit IC D/A Converter (AD562)*
- 1975 9-1. *Differential Instrumentation Amplifiers (AD521, 606M)*
9-2. *10-Bit Monolithic A/D Converter (AD7570)*
9-3. *Laser-Trimming ICs on the Wafer*
- 1976 10-1. *13-Bit Monolithic CMOS A/D Converter (AD7550)*
10-2. *Low-Cost DPM Challenges Analog Panel Meters (AD2026)*
- 1977 11-1. *Versatile Analog-to-Microcomputer Interface (RT1-1200)*
11-2. *Monolithic True-RMS-to-DC Converter (AD536)*
- 1978 12-1. *Monolithic $1\mu A/K$ Temperature-to-Current Transducer (AD590)*
12-2. *12-Bit IC Data-Acquisition System (AD363)*
12-3. *Fast 12-Bit Monolithic DAC/2-Chip ADC (AD565/AD574)*
- 1979 13-1. *MACSYM-2 Versatile Measurement And Control SYSTEM*
13-2. *High-Resolution Video Converters (MOID-1005)*
- 1980 14-1. *MACSYM 20 Lower-Cost Programmable MACSYM*
14-2. *Putting the AD558 Complete 8-Bit IC DAC on the Bus*
14-3. *Computerized Test System for Linear Devices (LTS-2000)*
- 1981 15-1. *Single-Board Measurement-And-Control System (μ MAC-4000)*

Dan Sheingold

*Out of print

THE AUTHORS

John Mills (page 3) is Senior Marketing Engineer for Subsystem Products at Analog Devices. John earned his BSEE degree from Northeastern University. He first joined Analog Devices as an Application Engineer, then became a Regional Sales Manager for Datel-Intersil and subsequently rejoined ADI in his present capacity. He enjoys softball, golf, a racquetball enthusiast.



Bob Butler (page 8) is Applications Engineer in the System Interface Products Group at Analog Devices. He has an Associate degree in Applied Science (Electromechanics) from Blue Hills Technical Institute (Mass.) and is currently working on a B.S.E.E. Prior to his present job he was a Senior Technician (Test Equipment) and an Engineering Assistant (Product Engineering).

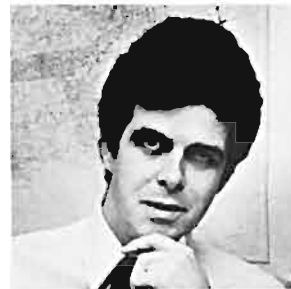

Mark Skillings (page 10) is Product Marketing Engineer in high-speed data-acquisition at the Computer Labs Division. Armed with a B.S. from Northeastern University, he is working toward an M.B.A. at the University of North Carolina. Since joining Analog Devices in 1972, he has worked in manufacturing and Quality Control, and most recently as an Application Engineer in System Components.



Ed Finn (page 10) is a Senior Engineering Technician at the Computer Labs Division in Greensboro, NC. A graduate of National Radio Institute and Roanoke Technical Institute, he has worked with microwave equipment, data-acquisition modules, automated material-handling equipment, and communications equipment.



(More authors on page 18)

analog dialogue

Route 1 Industrial Park, P.O. Box 280, Norwood, Mass. 02062
Published by Analog Devices, Inc., and available at no charge to engineers and scientists who use or think about I.C. or discrete analog, conversion, data handling and display circuits. Correspondence is welcome and should be addressed to Editor, *Analog Dialogue*, P.O. Box 280, Norwood, Massachusetts, U.S.A. 02062. Analog Devices, Inc., has representatives and sales offices throughout the world. For information regarding our products and their applications, you are invited to use the enclosed Business Reply card, write to the above address, or phone 617-329-4700, TWX 710-394-6577 or 710-336-0562, Telex 924 491, or cable ANALOG NORWOODMASS.

SINGLE-BOARD MEASUREMENT & CONTROL SYSTEM

μ MAC-4000: Intelligent, Expandable, Direct Data-Acquisition from Sensors Includes Signal Conditioning, Conversion, and Serial Communications

by John Mills

The μ MAC-4000* combines, on a single 9 1/2" X 13" board, signal conditioning and a/d conversion, as well as microcomputer control and ASCII data communication for 12 (or more) channels of analog sensor input and 8/8 (or more) lines of digital-control I/O. It solves efficiently, and in one master stroke, the sensor-to-computer interface problem: acquiring information from different types of sensors and converting the information into a form that a computer can deal with handily. It stands head-and-shoulders above existing solutions, which tend to be expensive, do not include fully integrated signal conditioning, and/or are excessively bulky. It does all this at prices starting from \$1800, in small quantity.

WHAT IS THE μ MAC-4000?

The μ MAC-4000 is an intelligent Measurement-And-Control system which includes complete sensor signal conditioning and multiplexing in the form of interchangeable plug-in modules, analog-to-digital conversion, digital inputs and outputs, a dual-mode power supply, and communication over a serial link. An on-board microcomputer controls all data-acquisition functions, linearizes sensors, checks limits, and converts data to engineering units.

The on-board power-supply accepts power from either the ac line or an external +24V dc source, providing automatic switching for uninterrupted operation if a brownout or ac power failure occurs. The μ MAC-4000 communicates with a host computer or terminal over an RS-232C or 20mA TTY serial link. The combination of all these facilities, together with the flexibility inherent in the plug-in-module approach, makes the μ MAC-4000 the most-powerful single-board measurement-and-control system yet available to industry.

HOW DOES THE USER BENEFIT?

- Screw terminals for sensor leads and appropriate on-board signal conditioning permit *direct connection* of signal sources.
- Serial digital data communications reduces field wiring, installation costs, and loss of data.
- The on-board microcomputer and its associated firmware unburden the host computer and make the μ MAC-4000 easy to use.
- An expansion port permits channel capacity to be increased without disturbance to an already existing setup.

The variety of signal conditioning and monitoring functions provided by this expandable single-board system suits it for many applications, large and small, in such diverse fields as factory automation, food-processing instrumentation, and energy management. It can be easily integrated into systems in either local or remote locations for monitoring, logging, and control of temperature, pressure, and flow, and where both analog and digital signals must be dealt with.

BASIC CONFIGURATION

As Figure 1 shows—and the illustrations on page 5 show in

*For technical data, use the reply card.

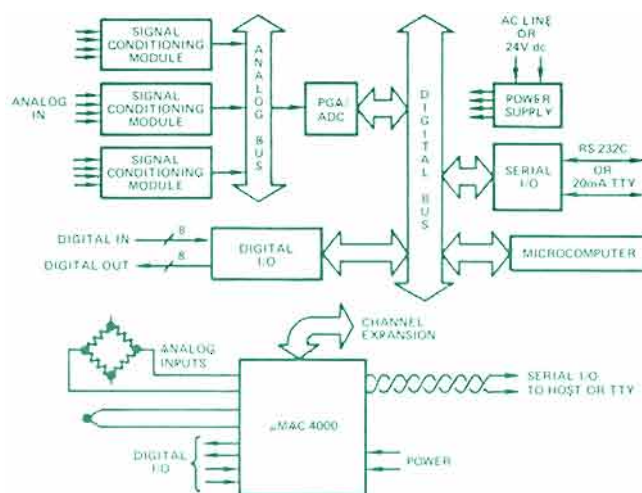

Figure 1. Basic μ MAC-4000 structure and application.

greater detail—three plugin Signal-Conditioning Modules allow a user to mix-and-match various types of sensors. Analog input signals are conditioned and multiplexed onto the internal Analog Bus; the resulting addressed signal is amplified by the Programmable-Gain Amplifier (PGA) to fit the input range of

(continued on the next page)

IN THIS ISSUE

Volume 15, Number 1, 1981, 20 pages

Editor's Notes, Authors	2, 18
Single-Board Measurement and Control System (μ MAC-4000).3	
Two-Wire Temperature Transmitters (4-to-20mA Loops) . . .	8
6-Bit Monolithic ADCs Convert in 10/20 Nanoseconds	10
High-Accuracy, Stable, 10.0000-Volt References	12
8-Bit, 8-Channel DAS Stores Conversion Results in On-Chip RAM	13
New-Product Briefs:	
High-Speed Sample-Holds (ADSHM-5, ADSHM-5K).	14
Latched CMOS Switches with Dielectric Isolation	14
HOS-100 Fast Follower Slews at 1000V/ μ s, Minimum	14
Flexible Linear-Device Tester is Programmable in BASIC	15
6 New MACSYM I/O Interfaces (Thermocouples, Digital I/O, IEEE-488, Analog Input, Digital Output, Interrupts).	15
True-RMS-to-DC Converter (AD636, for Low-Level Signals).	16
12-Bit ADCs in Hermetic DIP: AD5200 Series	16
Application Brief:	
High-Speed Instrumentation Amp with Software-Controlled Gains.	17
Worth Reading: <i>Synchro & Resolver Conversion</i> (new book), <i>Designer's Guide to High-Resolution Products, Signal-Conditioning Product Guide</i>	18
Across the Editor's Desk: Track-Holds Again	18
Potpourri.	19
Advertisement	20

the A/D Converter. The Digital Input/Output Port accepts 8 inputs (TTL or switch closures) and provides 8 TTL-compatible outputs. The Power Supply permits operation from either ac line power or +24V dc. The μ MAC-4000 communicates with any host via the Serial I/O Port, which contains a full-duplex universal asynchronous receiver-transmitter (UART). At the heart of the system is the Microcomputer, which controls data acquisition, performs linearization, conversion to engineering units, and limit checking, formats the output data, and controls interfacing.

FLEXIBLE CHANNEL CAPACITY

The basic μ MAC-4000 Master Board has a channel capacity of 12 analog inputs and 36 digital inputs and output lines, an optimum number for many small systems. The basic system can be expanded to a maximum of 384 analog channels and 512 digital lines, employing two levels of expansion.

First, the μ MAC-4010 Expander Board is available. Like the Master Board, each Expander Board has 12 channels of mix-match analog signal conditioning and 8/8 lines of digital I/O. It lacks only the a/d converter, microcomputer, and serial communication of the Master Board, which are shared in a cluster configuration (Figure 2). The AC1811 Card Cage is available to conveniently house and interconnect the members of a cluster. A four-card (max) cluster provides up to 48 analog channels and 64 digital lines.

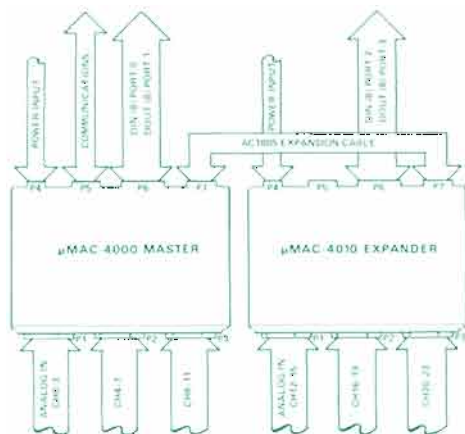

Figure 2. 2-board Master-Expander cluster.

For larger systems, consisting of up to 8 addressable μ MAC-4000s or clusters, the serial link is used for communication with the host. Either a party-line (multidrop) or radial (point-to-point) configuration may be used (Figure 3). The party-line connection is less costly to wire, but the radial connection can provide higher throughput.

SERIAL HOST COMMUNICATION

The members of a cluster communicate with the Master in parallel, in synchronism with the microcomputer's clock. The Master, in turn, communicates with the host processor or a terminal asynchronously in serial ASCII code, with error detection. Serial communication is in widespread use, with well-defined standards to enable terminals and computers to communicate without difficulty over distances of up to 10,000ft, using no more than four wires. The μ MAC board permits jumper selection of either RS-232C or 4-wire teletypewriter 20mA current loop, with asynchronous, full-duplex operation. Even or odd parity and baud rates up to 9600 are switch-selectable.

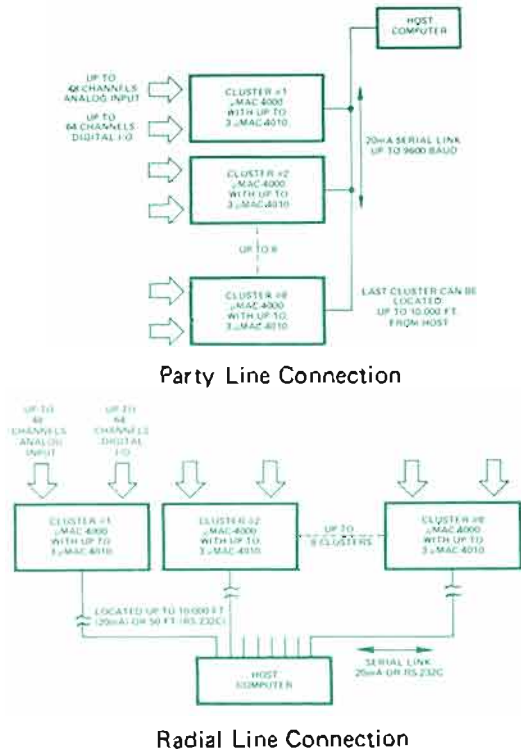

Figure 3. System configuration.

DIRECT CONNECTION TO SENSORS

Signal conditioning plays an important role in interfacing industrial signal sources to a data-acquisition system. Signal conditioning includes input protection, isolation, filtering, amplification, and excitation.¹

The plugin 4-channel signal conditioners available for use with the μ MAC-4000 have these properties to the degree necessary to handle inputs from the most-common forms of sensor, e.g., thermocouples, RTDs, semiconductor current-output thermometers (AD590), strain gages, and current transmitters (see also pages 8 and 9). Table 1 provides a cross-index between a number of representative signal sources and the type of conditioner module used for each.

(continued on page 6)

Table 1. Input multiplexer module selection (one required for each 4 channels)

Input Type/Span	Nonisolated Modules		Isolated Modules	
	High-Level Low-Level QMX01	Low Level with Excitation QMX02	Low Level QMX03	High Level QMX04
dc, ±25mV, ±50mV, ±100mV	✓		✓	
dc, ±1V, ±5V				✓
dc, ±1.0V, ±5V, ±10V	✓			
dc, 0-1mA Transmitter	✓		✓	
dc, 0-20mA Transmitter	✓		✓	
dc, 4-20mA Transmitter	✓		✓	
Type J Thermocouple	✓		✓	
Type K Thermocouple	✓		✓	
Type S Thermocouple	✓		✓	
Type T Thermocouple	✓		✓	
100Ω Platinum RTD, α = 0.00385		✓		
100Ω Platinum RTD, α = 0.00392		✓		
Strain Gage, ±30mV		✓		
Strain Gage, ±100mV		✓		
AD590		✓		

¹Considerable information on the electrical interfacing of sensors to analog electronics can be found in the *Transducer Interfacing Handbook—A guide to analog signal conditioning*, Analog Devices, 1980, \$14.50. The μ MAC-4000 and its signal conditioners solve most of the problems described there—and many others, in addition.

LEGEND

1. Multiplexed Signal-Conditioner Modules. Each QMX Module accepts 4 channels of analog input and provides preamplification, signal conditioning, multiplexing, and—if necessary—isolation. Optional choices permit a wide range of input sources: thermocouples, RTDs, strain gages, 4-20mA current loops, and general analog voltage and current signals in the millivolt, volt, or milliampere range. The DIP switches provide input type and range information.

2. Programmable-Gain Amplifier (PGA). Gain of the PGA is automatically adjusted to match the input signal to the full-scale range of the a/d converter.

3. A/D Converter. An integrating 13-bit ADC (12 bits + sign) converts at either 15 or 30 channels per second with a normal-mode rejection of 86dB at 50/60Hz.

4. Intelligence. A microcomputer with 6K of read-only memory and 1K of read-write memory provides supervisory control. The ROM contains firmware to control data-acquisition functions, a look-up table for sensor linearization, and data-format and communication routines.

5. Serial Input-Output. The serial communications section contains a UART (Universal Asynchronous Receiver/Transmitter), which provides asynchronous full-duplex operation. Jumpers select for either RS-232C or 4-wire 20mA TTY current-loop operation. The DIP switch selects baud rates of up to 9600.

6. Power Supply. There are two supplies in this section, an ac/dc for ac line power and dc/dc, to allow operation from either ac line power or +24V dc. The +24V dc input can be used for main or backup power using external batteries. Should a brownout condition or ac power-failure occur, the detector causes the supply to switch to dc input.

7. Digital I/O. The eight *inputs* are optically isolated for 300V peak; they can sense contact closures or accept TTL logic levels. The eight *outputs* are latched TTL, capable of sinking up to 24mA. This port is compatible with the μ MAC-4020 solid-state Digital I/O Subsystem or commercially available Manifold Cards.

8. Expansion Port. The μ MAC-4000 can be expanded to 48 analog input channels and 64 digital I/O channels by the addition of three μ MAC-4010 Expander Boards. The μ MAC-4010 permits low-cost channel expansion by sharing the system's a/d converter, microcomputer, and serial communications circuitry, located on the μ MAC-4000 Master board.

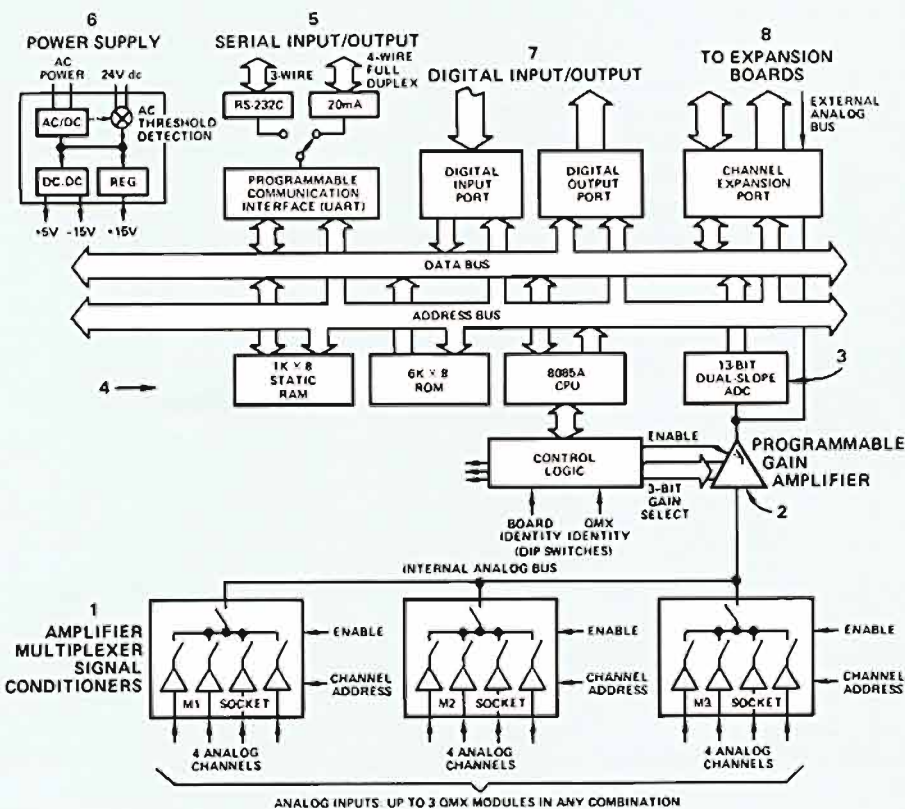
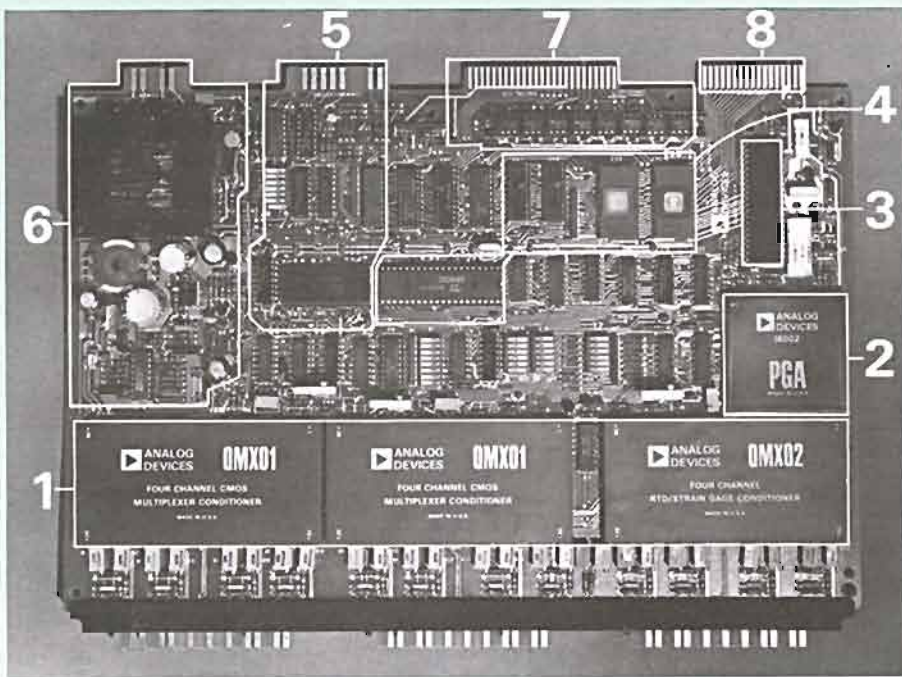

For example, the QMX01 handles 4 channels of high- or low-level differential analog inputs, including 4 types of thermocouples. As in all the modules, filtering and 130V normal-mode protection are inherent, to prevent damage if line voltage is accidentally connected across the input terminals. Common mode voltages up to $\pm 8.5V$ can be handled accurately. Gain and channel selection are controlled by the microcomputer.

The QMX02 interfaces with RTDs, strain gages, and the AD590 (or the AC2626 probe version), providing constant-current excitation for 3-wire RTDs. Figure 4 is a block diagram of the module, showing its principal functions and the degree to which it is controlled by the system microcomputer.

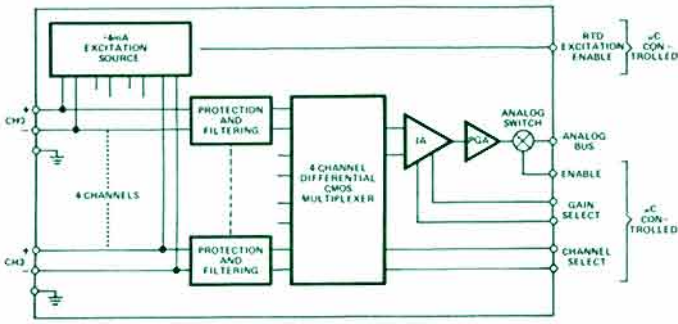

Figure 4. QMX02 block diagram.

Figure 5 is a block diagram of the QMX03 and QMX04 electro-magnetically isolated analog-input modules. The isolation, specified at $\pm 1000V$ peak continuous, provides both protection and 160dB of common-mode rejection. The filtering, combined with the integration in the a/d converter, provides 86dB of normal-mode rejection at 60Hz (i.e., 1V of 60Hz noise arriving with the input signal is, in effect, reduced to $50\mu V$).

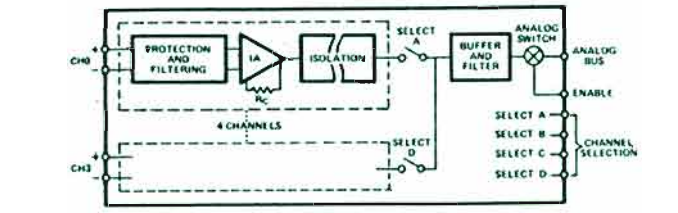

Figure 5. QMX03/QMX04 block diagram.

Thermocouples can be connected directly to the $\mu MAC-4000$, as Figure 6 shows, using a low-level input module (QMX01, QMX03) with the AC1800 isothermal connector. Cold-junction compensation circuitry in the AC1800 provides an accurate measure of the ambient temperature at the "cold" junction to provide correction for ambient temperature and its variations. The temperature at the connector is measured period-

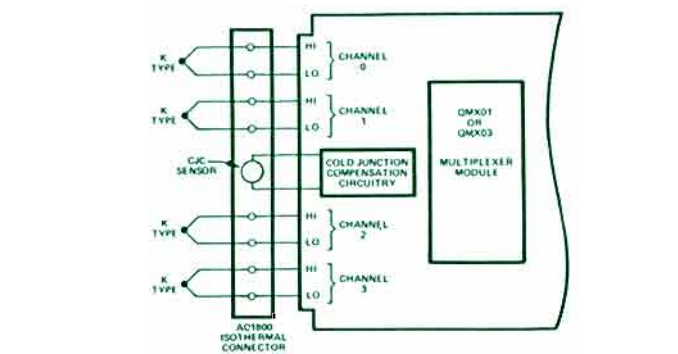

Figure 6. Thermocouple connection.

ically and stored in memory. It is then used to correct the thermocouple data digitally. The thermocouple characteristic is also linearized digitally, using a multisegment piecewise-linear approximation employing lookup tables stored in ROM. Digital linearization can provide low conformity errors that are stable with time and ambient temperature. Thermocouple types J, K, T, or S may be used and readout is in either $^{\circ}C$ or $^{\circ}F$.

COMMUNICATION PROTOCOLS

A data-communication protocol specifies the format in which data is transferred. The $\mu MAC-4000$ employs two types of protocol ("C" and "T") to communicate with any host Computer or Terminal. The "C" protocol is designed to be used with computers and controllers, where communication efficiency, reliability, and adaptability to a wide variety of host systems are necessary. The "T" protocol, which uses simple English-like commands, is designed for use with CRTs and teletypewriter terminals, for familiarization, debugging, system calibration, and manual control.

The $\mu MAC-4000$ will reply (only) in response to a command received over the serial link; this is known as command/reply (prompted) operation. Data is transmitted and received in standard ASCII format for each character, consisting of a start bit, 7 data bits, a parity bit, and one or two stop bits, as Figure 7 shows.

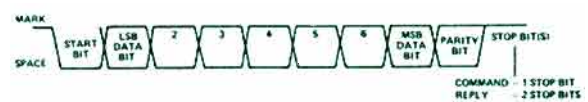
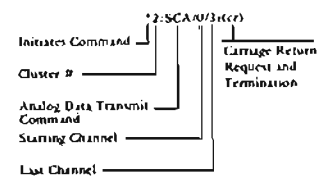

Figure 7. ASCII format.

COMMAND SETS

It is easy to operate the $\mu MAC-4000$, because the on-board microcomputer is programmed to respond to a simple command set. Through it, the host can delegate all measurement and control functions to the μMAC . The command set includes commands for transmitting analog and digital data, setting the digital output bits, activating channels, setting limits, and modifying the protocol. Some typical examples of commands and responses are shown below.

A typical command, using the "C" protocol, might be:



The command instructs the $\mu MAC-4000$ to transmit the latest data from channels 0 through 3 (47 max) of cluster number 2 (7 max).

The response might look like this:

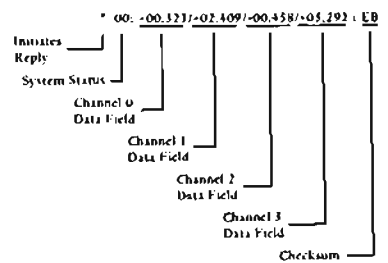

The carriage return of the command initiates the response. The first word is an indication of system status (errors, exceeded limits, backup power supply, etc.), to be described below. Then follow the data words requested, and finally a *checksum*, the sum of the numerical (hexadecimal) values of the preceding ASCII characters modulo 100_{16} (256). At the completion of the response, the μ MAC-4000 generates a carriage return and line feed; in addition, for each eight data fields, a carriage return is also generated.

A typical "T" command might be

CHANNEL 17 (cr)

This command requests the μ MAC-4000 to transmit the latest data from Channel 17. A typical reply might be:

CH 17 = +0024.7

If a thermocouple is connected to this channel, the response might indicate a temperature of 24.7°C.

This simple and efficient command/reply protocol scheme permits easy implementation by hosts using high-level languages (FORTRAN, RSX-11M, RMX-80), and it is easily debugged. Its key feature is the small amount of software necessary to support an intelligent system.

COMMUNICATION EFFICIENCY AND DATA INTEGRITY

The analog input channels are scanned continuously, and the data is converted into 7-column fixed-point decimal engineering units and stored in the μ MAC's on-board RAM. Because the latest data is available upon request, operation time for the task is kept to a minimum, since there is no need to wait for a new conversion to take place or to service an interrupt.

Serial-communication errors can be checked for by even or odd parity generation and checking, checksum generation and checking, and character-by-character echoback. In addition, the μ MAC's status message (see protocol "C") is another key feature in maintaining integrity of the system data. As Figure 8 shows, the status word consists of 8 bits, in groups of four, forming two hexadecimal digits with values from 00 to FF. A status reading of 00 indicates "no problem," and any other message identifies the nature of the problem. For example, an error message, 4C (0100 1100), would indicate the presence of checksum error, parity error, and limit exceeded.



Figure 8. 2-byte status word.

UNINTERRUPTIBLE POWER

Unlike some other board-level data-acquisition systems, the μ MAC-4000 can operate from either ac line power or +24V dc. The +24V dc can be used as either the main source of power, or it can be a backup source, using external batteries. Should a brownout condition or an ac power failure occur, on-board circuitry automatically switches to the +24V dc mode; it also sets a flag in the status message to inform the host that the battery backup mode has been activated. Primary ac voltage is jumper-selectable: 100V, 115V, 220V, or 240V; input power is transformed and regulated to the three dc voltages necessary to power the analog and digital circuitry.

APPLICATIONS

Some common applications include process control in the chemical and petrochemical industries, plastic extruder control systems, monitoring physical and electrical parameters and variables in electrical power-generating plants, energy-management and environmental systems, and engine test stands, as well as a wide variety of R&D laboratory uses. Its direct sensor input, compact size, low cost, and single-board construction make the μ MAC an ideal measurement-and-control system for OEMs, as well as end users.

A typical μ MAC-4000 application is a tank-farm facility, where crude oil is stored and transferred in pressurized systems, which must be continuously monitored and controlled. Sensors at the tanks are interrogated for pressure, temperature, and fluid level. Table 2 shows the types of inputs/outputs, and the relevant information channel. Figure 9 shows an implementation for two tanks, each instrumented with a μ MAC-4000.

Table 2. Typical measurements

Parameter	Measure	μ MAC
Oil-tank temperatures	Thermocouple-mV	QMX03
Tank vapor pressures	Strain gage	QMX02
Flows	Flow meter, 4-to-20mA	QMX01
Oil levels	Preset high-low limits	Digital Input
Tank-level alarm	On-off control	Dig. Out
Tank-pressure alarm	On-off control	Dig. Out
Valves	On-off control	Dig. Out
Valve position	On-off sense	Dig. In

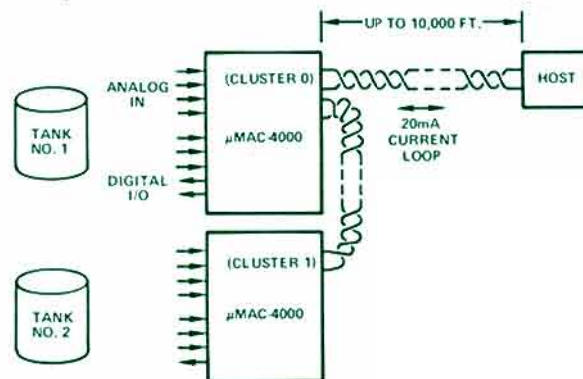

Figure 9. Typical tank-farm application.

THE OUTLOOK

The μ MAC-4000, μ MAC-4010, and hardware accessories (covers, card cages, cables, etc.), together with the family of QMX signal-conditioning modules, represent the first in a new series of single-board measurement-and-control products. New members of the family will be introduced in the near future, including the μ MAC-4020 solid-state Digital I/O Subsystem, to provide the digital ports of μ MACs with an isolated I/O capability. Also in the works is an analog output board with 4-to-20mA analog current transmission capability.

This new family for the first time combines all the functions necessary for multi-channel industrial data-acquisition and control, including *host-compatible software*, on a single board. The combination of these functions, together with the possibility of uninterruptible power supply, 100% burn-in at the factory, and easy *in situ* expansion, at low cost, makes this system worth considering whenever the circumstances call for new or upgraded on-line measurement-and-control systems in your industry. ▀

TWO-WIRE TEMPERATURE TRANSMITTERS

4-to-20mA Loop-Powered Transmission for a Variety of Sensors

New Family of Devices for Process Monitoring and Control

by Bob Butler



Transmission of analog input/output signals via 2-wire 4-to-20mA current loops is a long established practice in process control. Such systems have many benefits, including immunity to voltage drops and noise pickup, and the possibility of providing the power for transducer excitation and signal conditioning from a distant control room over the same pair of wires.

Now available from Analog Devices are a new family of temperature transmitters designed for use with popular sensors, such as thermocouples (2B52, 2B53), RTDs (2B58), and semiconductor sensors, such as the AD590 (2B57).^{*} Industrial applications for these devices include chemical and petrochemical production, power generation, food processing, and energy management.

WHY TWO-WIRE TRANSMITTERS?

A basic dilemma of process instrumentation is that low-level sensor outputs (usually millivolts) are generated in and must be somehow transmitted through environments that are rich in electrical noise from motors, high-power relays, induction furnaces, and the like. Besides the threat to signal integrity from interference, the sensor information must also run the gamut of energy losses associated with long runs of wire and substantial common-mode voltages between the "grounds" at the process and the distant instrumentation (Figure 1). Finally, power suitable for exciting the sensor and for providing local signal conditioning may not be readily available in its vicinity.

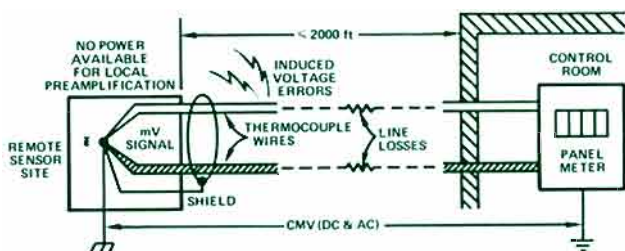

Figure 1. Direct sensor transmission of low-level voltage output—major problem areas.

A two-wire current-signal transmitter located near the sensor can provide a resolution of this dilemma (Figure 2). First, the output of the transmitter is in the form of a 4-to-20mA current. The analog signal information is unaffected by noise-induced voltages, by voltage drops, or by contact potentials, and it may be sent over distances of up to and beyond 2000

^{*}Use the reply card for technical data on any of these devices.

feet (610 meters) without degradation. Inexpensive, unshielded copper wire may be used, usually in the form of a twisted pair. A number of pairs may be bundled together in cables without cause for concern about crosstalk between channels.

DC power is furnished to the transmitter—which may include facilities for amplification, excitation, cold-junction compensation, even linearizing—over the same two-wire line by a power supply at the receiving end; a typical range of usable supply voltage is +12V to +60V. Since the transmitter may be close to the sensor, long runs of expensive shielded sensor wire are unnecessary.

If the sensor must be in conductive contact with the medium being monitored, a transmitter having galvanic isolation between its input circuit and the output/power circuit may be used to eliminate errors and hazards due to common-mode voltage. Since the minimum output current is 4mA, there is a clear distinction between a "zero" measurement and an open-circuited transmission line.

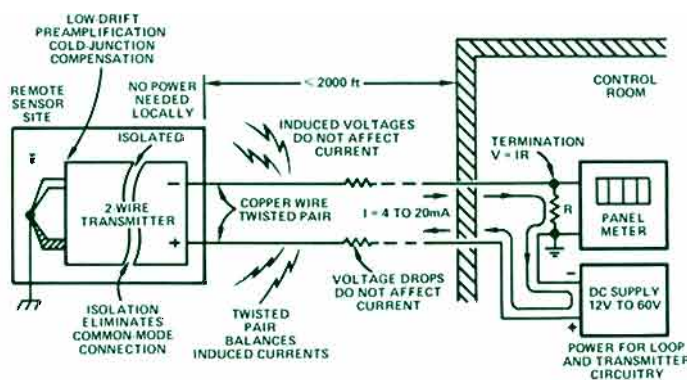

Figure 2. Isolated 2-wire current transmission of sensor output solves problems of Figure 1.

WHAT TEMPERATURE SENSORS ARE USED?

Temperature is the most-widely measured process variable, and the thermocouple is the most-commonly used sensor. Seven standard types are available to measure temperatures in ranges from -200°C to +1800°C. Thermocouples are often directly in contact with (i.e., grounded to) the measured environment and may require isolation to protect instrumentation and provide immunity from noise and common-mode effects. Since they are self-generating, they require no excitation. Resistance temperature detectors (RTDs) are also quite popular; they are accurate, repeatable, and useful over a reasonably wide range of temperature (-220°C to +850°C for platinum).

Semiconductor temperature detectors, such as the AD590 (and its probe form, the AC2626), are linear and provide a substantial output current with a sensitivity of $1\mu\text{A}/^\circ\text{C}$ from -55°C to $+150^\circ\text{C}$.

A short tabular summary of these types is provided in Table 1. For further information on these sensors, their electrical interfacing properties, and electronic circuitry for interfacing with them in various applications, the *Transducer Interfacing Handbook*† is a worthwhile reference.

Table 1. Transducer Characteristics

TYPE	TEMPERATURE ELECTRICAL I/O CHARACTERISTICS	COMMENTS
Thermocouples	Low source impedance, typically 10Ω . Voltage-output devices. Output shift is 10^4 s of microvolts/ $^\circ\text{C}$. Outputs typically in the millivolts at room temperature.	Low voltage output requires low-drift signal conditioning. Small size and wide temperature range are advantages. Requires reference to a known temperature. Nonlinear response.
Platinum and other RTD's	Resistance changes with temperature. Positive temperature coefficient. Typical impedance (0°C) 20Ω to $2k\Omega$. Typical sensitivities $0.1\%/^\circ\text{C}$ to $0.66\%/^\circ\text{C}$, depending on material.	Highly repeatable. Good linearity over wide ranges. Requires bridge or other network for typical interface.
Semiconductor sensors	Voltage, current, or resistance functions. Voltage types (diodes) require excitation current. Current types (AD590) require excitation voltage. Resistive types (bulk silicon) may use either type of excitation.	Many devices are uncalibrated and require significant signal conditioning. AD590 is calibrated, linear, and requires minimal signal conditioning.

TRANSMITTERS FROM ANALOG DEVICES

Analog Devices has a growing family of two-wire transmitters that interface with these sensors and provide standard 4-to-20mA outputs, as defined by ISA Standard S50.1. These compact devices use single-board construction for high reliability and accuracy, as well as low cost. Modules 2B52/2B53/2B57A-1/2B58 are packaged in rugged metal enclosures that provide RFI shielding and can be mounted either on-site or in the available Snaptrack-type relay mounting systems. All input-output connections are made via screw terminals on a barrier strip; zero and span-adjustment pots are accessible for easy calibration in the field. Thermocouple burnout is indicated by an overranged output, 22.5mA to 25mA.

Models 2B52 and 2B53 are high-performance low-cost temperature transmitters designed to interface with type J, K, or T thermocouples. The 2B52 has high input-to-output isolation (600V rms) and high common-mode rejection (160dB at 60Hz). Its block diagram is shown in Figure 3. The 2B53 is functionally equivalent but does not provide galvanic isolation.

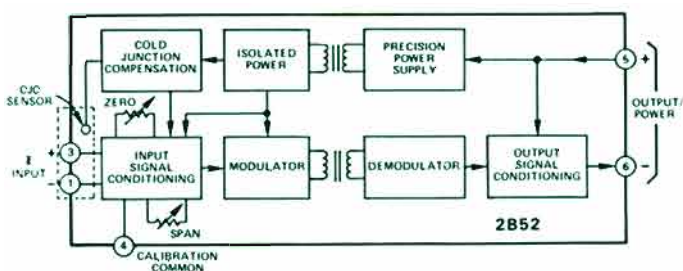

Figure 3. Model 2B52 functional block diagram.

†Analog Devices, Inc., 1980. Available for \$14.50 from P.O. Box 796, Norwood MA 02062.

between input and output. Both are high-accuracy (0.1%) devices; they include cold-junction compensation to ensure accurate performance over a wide range of ambient temperature and will operate over a wide range of power-supply voltage ($+12\text{V}$ to $+60\text{V dc}$). They have open-input detection and will of course work with other types of millivolt-level signal sources. Prices for 2B52A/2B53A start at \$160/\$114 in 100s.

Model 2B57 is a low-cost 2-wire transmitter designed to operate with ADI's family of inherently linear AD590 semiconductor sensors (including the AC2626 probe version), providing a standard 4-to-20mA output proportional to temperature over the -55°C to $+150^\circ\text{C}$ temperature range. With its span drift of $\pm 0.005\%/^\circ\text{C}$ max and linearity to within $\pm 0.05\%$, the 2B57 maximizes accuracy in measurements using the AD590. Zero and span adjustments permit the input range to be trimmed for spans from 205°C to as little as 20°C . The $1.5''\times 1.5''\times 0.4''$ ($38\text{X}38\text{X}10.2\text{mm}^3$) epoxy module may be mounted on the AC1583 mounting card, which measures only $1.88''\times 3.88''$ ($48\text{mm}\times 99\text{mm}$); this small card permits the 2B57 and the AD590 to be mounted in standard-size thermostat or utility boxes for remote temperature sensing in multipoint energy-management applications. An aluminum-case option (2B57A-1) is available to provide RFI immunity when the 2B57 is used in noisy environments. Since the AD590 has $\pm 200\text{V}$ insulation, an isolated version of the 2B57 is not necessary. Price of the 2B57A is \$39 in 100s.

Model 2B58, a transmitter designed for use with 2- or 3-wire 100Ω platinum RTDs, has high accuracy (to within $\pm 0.2\%$), plus internally provided sensor excitation and linearization. Again, isolation is not required, since RTD construction can provide the necessary insulation. Price in 100s is \$125.

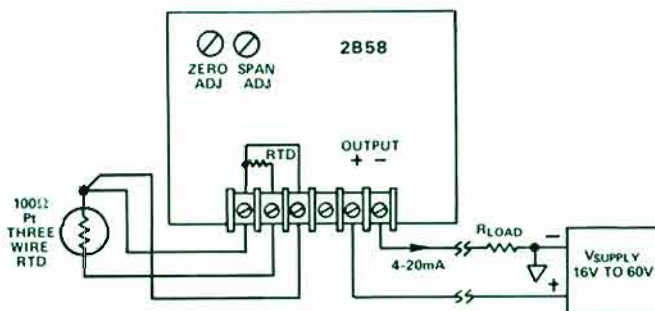

Figure 4. 2B58 basic connection.

THE EXTENDED TRANSMITTER FAMILY

Besides the transmitters described here, ADI manufactures other components having 4-to-20mA output. They are listed in Table 2.

Table 2. 4-to-20mA loop products

MODEL	INPUT	ISOLATED?	COMMENTS
2B20	0 to +10V	Common	Common supply
2B22	0 to +1V or 0 to +10V	Isolated ($\pm 1500\text{V pk}$)	Output loop-powered, input separately powered.
2B52 } 2B53 }	J, K, T Thermocouple	{ Isolated (600V rms) } { Common }	Loop-powered, provides cold junction compensation.
2B57	AD590, AC2626	Insulated sensor ($\pm 200\text{V}$)	Loop-powered, provides excitation
2B58	2- or 3-wire 100Ω Pt RTD	Insulated sensor	Loop-powered, provides excitation and linearizing
DAC1420	8-bit digital	Common	Loop-powered
DAC1422	10-bit digital	Common	Loop-powered
DAC1423 (ISO-DAC™)	10-bit digital	Isolated (1500V dc)	Loop-powered

6-BIT ADCs CONVERT IN 10/20 NANoseconds

Monolithic AD5010KD/6020KD: Packaged in 16-Pin DIP

Latched Flash Conversion, Expandable to 7 or 8 Bits

by Mark Skillings and Ed Finn

The AD6020KD* is a 6-bit monolithic analog-to-digital converter capable of performing ratiometric conversions at rates up to 50MHz; the AD5010KD* performs 6-bit conversions at rates up to 100MHz. Both types are packaged in the 16-pin hermetically sealed ceramic dual in-line package, and are characterized by considerably lower cost than the few available alternatives currently on the market (\$84/\$189 in 100s, for AD6020KD/5010KD).

The extremely high scanning rates that they make possible are ideal for video systems and for any application calling for digitizing of high-frequency signals, for example, radar and x-ray equipment, medical imaging systems (x-ray and ultrasound), and measuring instruments, such as digital storage oscilloscopes and transient recorders.

An overflow output is available to indicate that the input signal equals or exceeds the +V reference. Not only is this feature useful for overrange indication; it is also the key to the use of these converters in 7- and 8-bit conversion by cascading of references and wire-or'ing of digital outputs, as will be described below.

HOW THEY WORK

The low nonlinearity and high conversion rate are achieved by the use of ECL (emitter-coupled logic) and the method of "flash" conversion, in which all bits are generated at the same time.

Figure 1 is a block diagram of the AD6020KD/5010KD. The circuit comprises a resistive reference divider, a set of 64 comparators followed by latches, encoding logic, and a 6-bit parallel output stage, with an additional *overflow* bit.

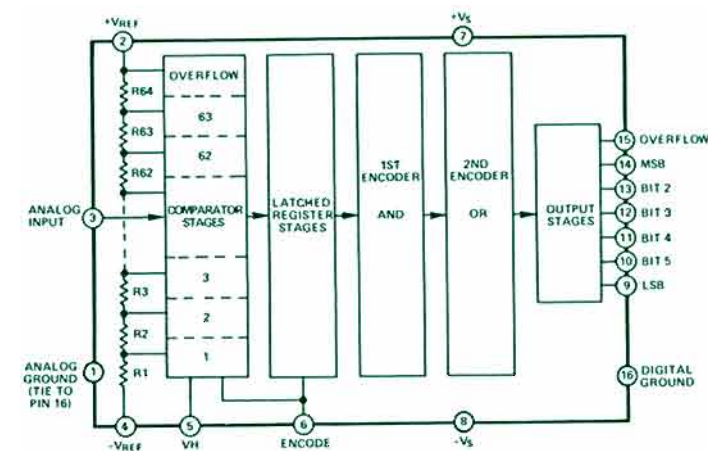

Figure 1. Block diagram of the AD6020KD/5010KD high-speed ADC.

The analog input is compared with the appropriate fraction of the external reference voltage in each comparator. All comparators with reference voltage greater than the analog input

remain at logic zero; the other comparators are all switched to logic one. A set of registers receive the comparator outputs. While the ENCODE input is low, the latches are transparent; at the instant the ENCODE goes high, the latches go into *hold*, and the inputs from the comparators can no longer influence their output. The encoders convert the "thermometer" output of the latches to a 6-bit binary byte, which appears at the output.

Meanwhile, the outputs of the comparators continue to respond to changes of the analog input; when the ENCODE goes low again, the registers respond to the new state of the comparator outputs. At the fastest conversion rate of 100MHz, the AD5010KD requires 6ns for the register outputs to be valid (logic 0) and, after the ENCODE goes high (logic 1), 4ns for the digital output to become valid. Since the registers perform the sample-hold function, an external sample-hold is unnecessary. The aperture uncertainty is typically 25ps.

Over the rated ambient temperature range (0° to 70°C), linearity is essentially insensitive to temperature, and there are no missed codes. The reason for this is that the linearity depends principally on the tracking of resistors (i.e., resistance ratios), not their absolute value. The comparator thresholds hold to within a small fraction of 1 LSB. In addition, the low dissipation of the chip (450mW) results in lower temperature rise than for comparable devices. Required power supplies are +5V and -5.2V, with $\pm 5\%$ tolerances.

APPLYING THE AD6020KD/5010KD

First, it is important to note that the design principles for high-speed conversion have not been revoked by the availability of a chip that performs most of the work. Certainly, the user's task has been greatly simplified by the high degree of integration of the conversion function; however (s)he must still be concerned with timing, providing an adequate ground plane, bypassing of power supply and reference runs, placement of components and signal leads, and appropriate termination of inputs and outputs. For the convenience of users evaluating the devices, evaluation boards, i.e., the AD6020/PCB and the AD5010/PCB, are available. Their functions are described elsewhere in this article.

Increased Resolution. Figure 2 shows in principle how two 6-bit converters are connected to obtain 7-bit resolution. The reference-resistor strings are connected in series and driven at the high, low, and mid-scale points. The 6-bit outputs of both devices are wired together and perform an *or* function: if either output is high at the *j*th line, the *j*th line will go high. The MSB (most significant bit) is provided by the overflow of ADC #1.

When the analog input is below half-scale, the overrange bit is low, and so are the output bits of ADC #2. Thus, the outputs of ADC #1 drive the output lines in response to the analog input. When the analog input is above half-scale, the overrange

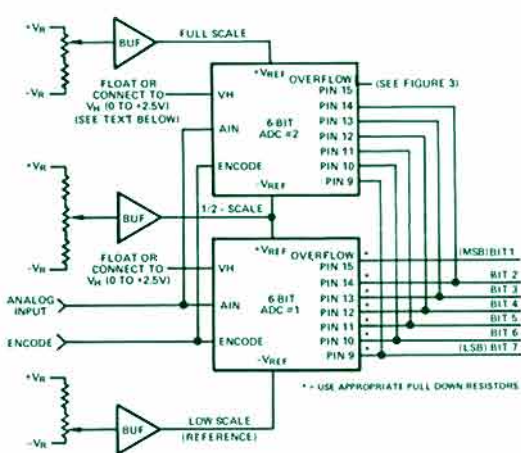

Figure 2. Connecting two 6-bit ADCs for 7-bit operation.

bit of ADC #1 is high (the MSB), when it goes high, it acts as a carry: all the other bits of ADC #1 go low. ADC #2 converts the residual upper half-range, and its outputs drive the output lines. Note that speed is undiminished, because the conversions are occurring in parallel.

For eight-bit resolution, two additional converters are stacked above ADCs #1 and #2 and used in the same way, with the reference span divided into four equal parts; a small amount of external logic is used to establish Bit 2 correctly and minimize time skew.

Overrange Without Rollover. We have noted above that when the overrange bit goes high, the data bits go low. If this is undesirable, in 6-bit applications, a hex *and* gate may be used, as shown in Figure 3, to bring the outputs high; it is wire-or'd with the outputs. This circuit also shows more details of actual connections to the AD6020KD/5010KD. Note that the outputs of the reference regulator amplifiers, and the VH (hysteresis) input, are capacitively bypassed. The Hysteresis Control input controls the comparator thresholds in applications at higher frequencies. In most applications it is simply left floating.

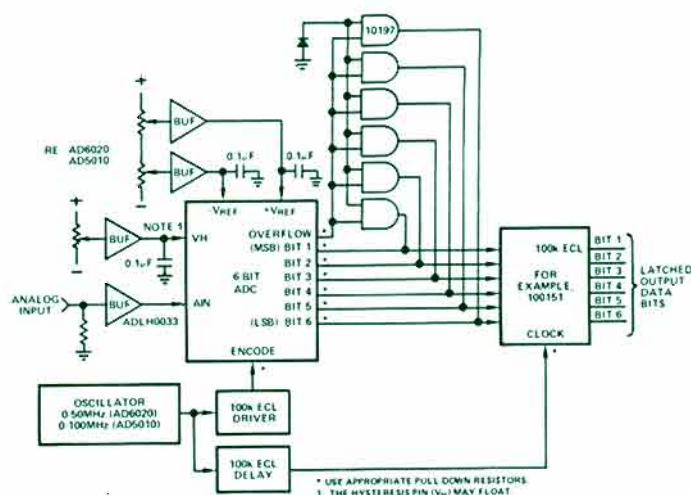

Figure 3. Typical connection scheme for 6-bit operation.

EVALUATION BOARD

The AD6020KD/PCB Evaluation Board makes it easy for a user to be up-and-running with the AD6020KD with little time and effort. As Figure 4 shows, the board provides an optimally

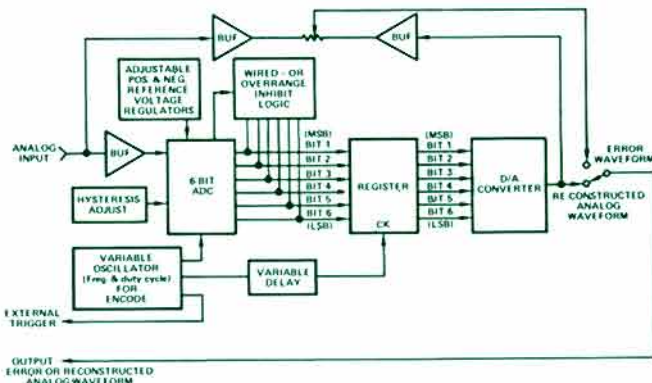

Figure 4. 6-bit ADC evaluation board.

implemented test bed that even includes a variable frequency-and-duty-cycle encode oscillator and a DAC for signal reconstruction.

In this friendly environment, the user can investigate the effects of changing the analog input, $+V_{REF}$ and $-V_{REF}$, the hysteresis control, the encode frequency and duty-cycle, and the timing of the external 6-bit output register, on the reconstructed analog waveform, and even study the difference between the input and output waveforms. Test points are provided at strategic points throughout the circuit so that the user may look at relevant signals at various stages in the process.

The oscillator is supplied on-board because of the need for a clean encode pulse that is variable up to Very High Frequency with adjustable duty cycle. The 6-bit register and DAC are provided for ease in evaluation of the ADC's performance, as observed via a reconstructed waveform. Analog buffering is provided wherever required, and the regulated analog reference voltages are adjustable over the $\pm 2.5V$ range. A timing delay adjustment is provided for the DAC register strobe so that ADC conversion time can be readily evaluated.

Also provided on-board is the wired-or overrange inhibit logic, mentioned above. Naturally, every effort has been made to observe all of the precautions necessary to optimize high-speed performance and permit valid tests of the ADC's behavior. Evaluation boards are available from stock. ▶

Table 1.

PERFORMANCE CHARACTERISTICS IN BRIEF
(typical at $+25^{\circ}C$ and rated supply unless noted otherwise)

	AD6020KD	AD5010KD	UNITS
Resolution	6	6	bits
Input Range	± 2.5	± 2.5	V max
Linearity Error	1/4	1/4	LSB
Input Capacitance	25	25	pF
Conversion Time	20	10	ns
Aperture Time	2	2	ns
Aperture Jitter (uncertainty)	25	25	ps
Scan Frequency (min)	50	100	MHz
Digital Inputs/Outputs	ECL	ECL	
Power-Supply Voltage			
$+V_S/-V_S$	5.0/-5.2	5.0/-5.2	V
$+V_S/-V_S$	5.25/-4.94	5.25/-4.94	V max
$+V_S/-V_S$	4.75/-5.46	4.75/-5.46	V min
Power Dissipation	450	450	mW
Temperature Range (Ambient)	0 to 70	0 to 70	$^{\circ}C$

STABLE HIGH-ACCURACY 10.0000V REFERENCES

Error Less than $\pm 1.45\text{mV}$ Over Temperature - An Industry First

AD2710L/12L Hybrids in 14-Pin Ceramic DIP

by Ron Knapp

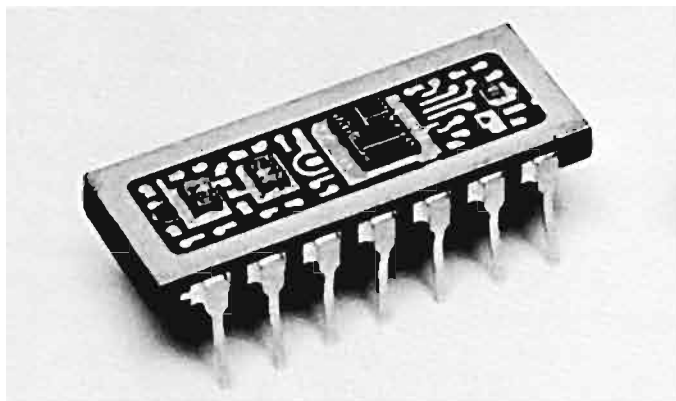

The AD2710L* is a +10.0000V dc voltage reference, accurately set to within $\pm 1\text{mV}$ at 25°C and guaranteed to remain within $\pm 1.45\text{mV}$ over the 0°C to 70°C temperature range. The AD2712L* is a dual regulator with plus and minus 10.0000V outputs, with the same accuracy specification. Packaged in a 14-pin ceramic DIP, these devices are directly interchangeable with the popular AD2700 and AD2702, but with greatly improved accuracy specifications.

Typical applications include no-problem performance upgrading of circuits and systems originally designed to use the AD2700 family, precision referencing for a/d and d/a converters of up to 16-bit resolution, test and measurement systems, as well as portable and field instrumentation, where the high power called for by references requiring or containing temperature-stabilizing ovens would be intolerable. The AD2710 series is also pin-compatible with some products not manufactured by Analog Devices, e.g., the MN2000 and R675 series.

WHY THEY'RE BETTER

The AD2712's basic circuit is shown in Figure 1. It consists essentially of the AD2710 regulator circuit and an inverting amplifier. The selected precision regulator-diode's terminal voltage is amplified by the feedback ratio of amplifier A1. The diode current is derived from the regulated output, since its variation is extremely small, the diode voltage remains practically constant. Although it is a tried-and-true

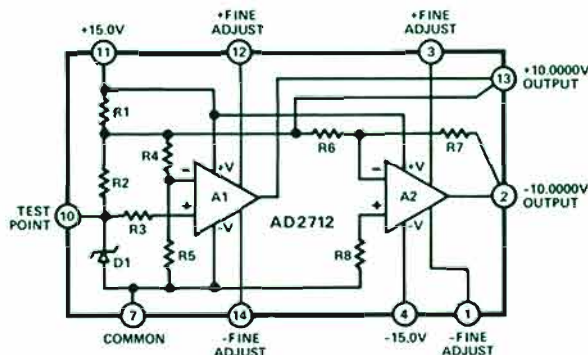

Figure 1. AD2712 block diagram.

*For technical data, use the reply card.

configuration¹, outstanding performance has been gained for this circuit by judicious component selection, careful interconnections, and automatic laser-trimming of both the output voltage and its temperature coefficient. Figure 2 shows a plot of typical behavior with temperature.

Not the least of the factors contributing to the performance, as well as the stability, reliability, and small size of these devices, is the unique Analog Devices "Slam" package (to be described in the next issue). It is a side-brazed DIP, using an integrated multilayer ceramic construction, significantly reducing the number of wirebonds and eliminating the need for glass seals around the device leads. The interconnecting metalization runs are buried, deep inside the package, not only increasing reliability but also making possible greater accuracy. Finally, the package has low thermal resistance, resulting in lower junction temperatures, smaller gradients, and more-reliable operation.

PERFORMANCE

Two performance grades of each type are available; all grades have initial error less than 1 millivolt, but the lower-cost AD2710K/12K still have a respectably small total error over the 0° to 70°C temperature range, $\pm 1.90\text{mV}$, compared to $\pm 1.45\text{mV}$ for the AD2710L/12L. The initial error can be adjusted to null, via an external fine-adjust circuit.

Input voltage range is +13V to +18V (+13.5V to +16.5V for specified performance); line regulation is $200\mu\text{V}/\text{V}$, load regulation is $100\mu\text{V}/\text{mA}$ max (0 to $\pm 5\text{mA}$), and effective output resistance is 0.05Ω . Noise (0.1 to 10Hz) is typically $30\mu\text{V}$ p-p, $50\mu\text{V}$ max, and long-term stability is 25ppm/1000h. Price (100s) is \$32/\$42 for AD2710K/L, and \$39/\$52 for AD2712K/L.

APPLICATIONS

The AD2710 series can replace calibration-standard modules and instruments in applications at a fraction of the cost. Easier to use and having higher voltage than chemical cells, these devices are less costly or less bulky (or both) than solid-state reference circuits—and ac line voltage for heaters is not required. Their combination of stability, reliability, and ease of use—all at low cost—is hard to beat! ▣

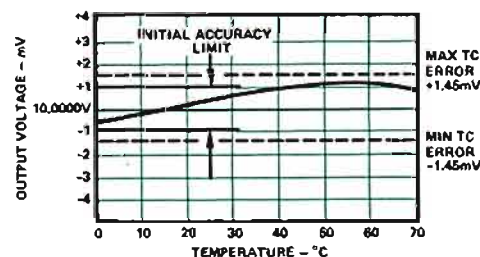

Figure 2. AD2710L typical output deviation with temperature.

¹ It appears, for example, in the *Analog-Digital Conversion Handbook*, 1972, (Analog Devices), p. II-42, and page 119 of *Analog-Digital Conversion Notes*, 1977 (\$5.95).

8-BIT 8-CHANNEL DAS STORES CONVERSION RESULTS

Reading Any Channel Is As Simple As Reading from Memory

Monolithic AD7581 Minimizes Software As Well As Hardware

The single-chip CMOS AD7581* continuously scans 8 analog input channels, converts them to digital, and stores the data in a bus-addressable RAM. The AD7581 interfaces directly with 8080, 8048, 8085, Z80, 6800, and other microprocessor systems. Data can be read at any time for any channel. Prices start at \$13.90 (100s).

WHAT IT IS

The AD7581 (Figure 1) consists of an 8-bit ratiometric successive-approximation a/d converter, an 8-channel analog multiplexer, an 8 X 8 dual-port RAM, three-state drivers (for interface), address latches, and microprocessor-compatible control logic. When used with appropriate references, it accepts either unipolar inputs (0 to +10V, binary output) or bipolar inputs (-5V to +5V, offset-binary output).

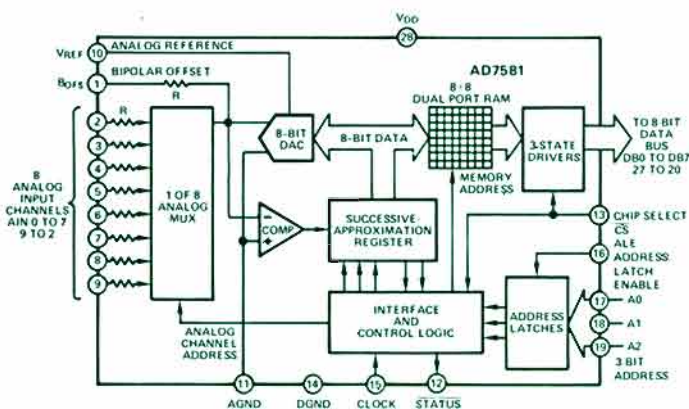

Figure 1. Block diagram of the AD7581 chip.

The successive-approximation conversion takes place on a continuous, channel-sequencing, basis using microprocessor control signals for the clock (when used with a μ P). Data is automatically transferred to its proper location in the 8 X 8 RAM at the end of each conversion. When under microprocessor control, a READ DATA operation is allowed at any time for any channel, since on-chip logic provides interleaved direct memory-addressing (DMA) to ensure that memory updates take place at instants when the μ P is not addressing memory.

The parallel 8-bit three-state data outputs are connected directly to the data bus, and the three-bit address may be tied either to a separate address bus or to a multiplexed address/data bus. In the latter case, the ALE (address-latch enable) input facilitates operation on the shared bus. Examples of interconnections with both types of microprocessor bus are shown in Figure 2.

WHAT IT MEANS

The AD7581 saves the user effort in design, programming, and debugging. Beyond that, it provides a substantial saving of processor time, since, in microprocessor applications, reading any channel is no more difficult than reading from a memory location. The experienced user will recognize this as a real benefit, since a considerable amount of software overhead

*For technical data, use the reply card.

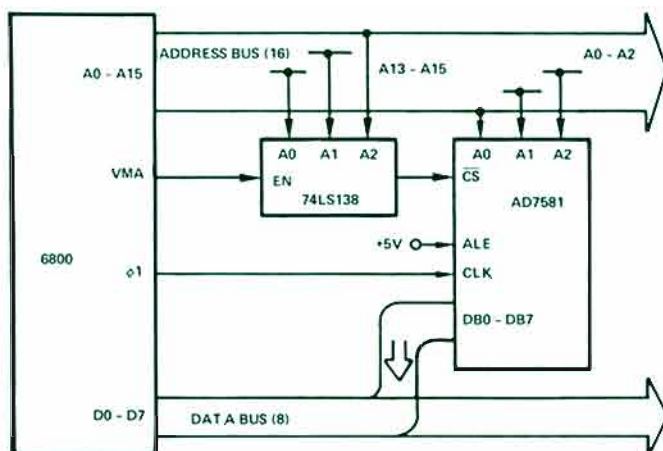

a. AD7581/6800 interface, with separate data and address buses.

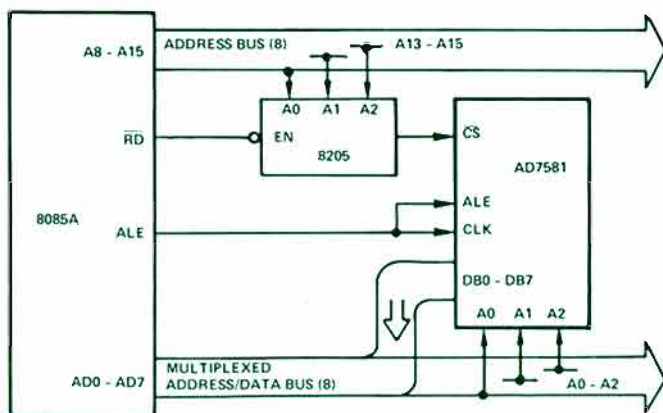

b. AD7581/8085 interface, with a shared address/data bus.

Figure 2. Interfacing examples.

must be expended with conventional data-acquisition-system structures. Typically, the channel to be converted has to be identified, switched-to, converted, and read out, all of which takes program steps and processor time. In essence, the AD7581 interfaces like an 8-byte read-only memory.

PERFORMANCE

The AD7581 operates from a single +5V supply. In fixed-reference unipolar applications, it requires a -10V reference (the usable reference range is from about -5V to -15V), typically provided by the AD581.* The AD7581 converts with no missed codes over the operating temperature range: 0°C to +70°C (K/L versions) or -25°C to +85°C (B/C versions), and its offset and gain can be trimmed externally. Each conversion requires 80 input clock periods, and a complete scan through all channels calls for 640 input clock periods. Although valid data can be read at any time, an indexed STATUS output permits coordination of readings with conversions for fastest access to data. If the inputs are tied together, the AD7581, acting as a FIFO, stores 8 consecutive samples of the same input. ■

HIGH-SPEED SAMPLE-HOLDS

ADSHM-5 Replaces Other SHM-5's ADSHM-5K OBSOLETES Other SHM-5's

If the track/sample-hold sockets in your system are designed for SHM-5 high-speed sample-holds, there's good news! You now have a choice of upgrading the socket by simply plugging in the new ADSHM-5K* module, with its 12MHz bandwidth, 300V/ μ s slew rate, 250ns/100ns acquisition time (10V signal to 0.01%/0.1%) from tracking mode, and 100ps aperture uncertainty.

Or, if your application calls for an "ordinary" 350ns acquisition time to 0.01%, with 250ps aperture uncertainty, you can continue to use the ADSHM-5* with some saving in cost. The ADSHM-5 is priced at \$179 (1-9), the ADSHM-5K at \$199.

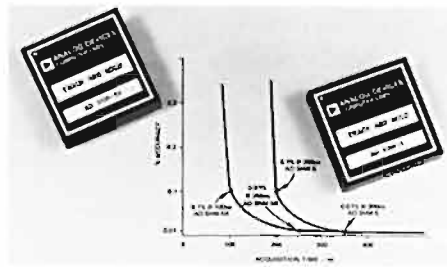
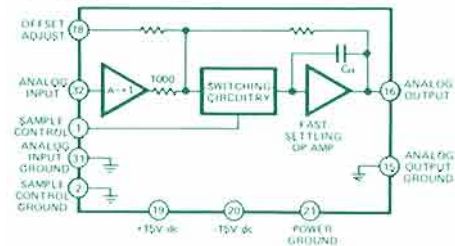

Both devices have aperture delay time of 20ns. Their maximum output offset vs. temperature is $\pm 30\mu\text{V}/^\circ\text{C}$ (0° to 70°C), with a maximum offset (adjustable to zero) of $\pm 50\text{mV}$. They both go into *track (sample)* with TTL logic 1, and into *hold* at TTL 0. And they are packaged in a 2"X2"X0.4" module.

The "K" has lower bias current (2nA max vs. 250nA max), greater output current (50mA vs. 40mA), and less droop in *hold* (12 vs. $20\mu\text{V}/\mu\text{s}$ max). For applications where the input buffer must swing 10V when acquiring data, the "K" requires only 300ns to 0.01%, vs. 1000ns for the SHA-5. \square

HOS-100 FAST FOLLOWER

Slews @ 1000V/ μ s min; 125MHz -3dB Bandwidth

The HOS-100* is a follower amplifier designed for applications calling for high-current drive at frequencies from dc to more than 125MHz and currents up to 100mA peak. Packaged in a TO-8 hermetically sealed metal can, it is available in two versions. For commercial/industrial use (-25°C to $+85^\circ\text{C}$ case temperature), specify the HOS-100AH; for the military range (-55°C to $+125^\circ\text{C}$), specify the HOS-100SH. Processing to MIL-STD-883B is also available (HOS-100SHB). Prices are \$12.25/\$23.00/\$29.50 in 100s.



The figure below illustrates the usual mode of operation of the HOS-100, as an inside-loop buffer for an operational amplifier of more-modest output capabilities, in the usual gamut of wideband feedback operations. Like the ADLH0033—and other 0033 types—the HOS-100 can provide $\pm 10\text{V}$ output with 100 Ω load and can slew at 1500V/ μ s—at lower cost.

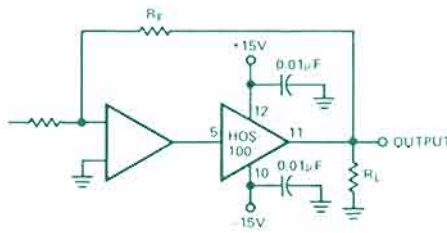

Typical applications are in current boosting, high-speed ADC buffering, driving coaxial cables and transmission lines, video impedance transformation, and for amplification in nuclear instruments. \square

CMOS SWITCHES

With Data Latches & Dielectric Isolation

The AD7590DI/91DI/92DI* are CMOS analog switches in dual in-line packages. Protected by dielectric isolation, they offer, for the first time, latched analog switching, in a package that is pin-and-functionally compatible with the popular AD7510DI series when $\overline{\text{WR}}$ is held low. The performance of these devices is improved—for example, I_D and I_S , on and off, are five times less, and output leakage current is seven times less than for the AD7510DI family.

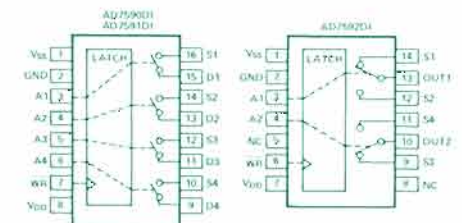
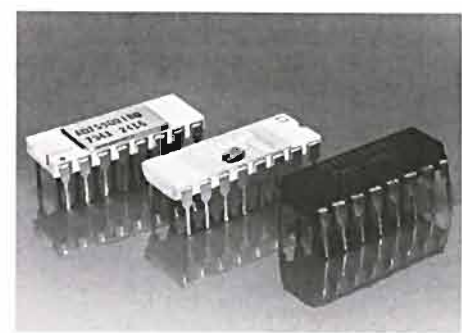

Latched switching means that the AD7590 family are easier to use in microprocessor-controlled gain-setting, analog signal routing, and control circuitry. *Dielectric isolation* means that the switches are protected from overvoltage $\pm 20\text{V}$ beyond the supplies, continuously. The switches are compatible with TTL and CMOS logic levels.

As the diagram shows, the AD7590DI and AD7591DI are quad SPST switches, packaged in a 16-bit DIP. The AD7590 switches are on for address *high*; the AD7591 switches are on for address *low*. The AD7592DI is a pair of SPDT switches in a 14-pin DIP.

Plastic and hermetically sealed ceramic packages are available. Prices start at \$7.40 (100s, plastic). \square

*Use the reply card for technical data.

*Use the reply card for technical data.

FLEXIBLE TESTER You Can Program LTS-2010 in BASIC



The LTS-2010⁺ is a powerful benchtop (-size) tester for linear integrated circuits. Similar in function to the LTS-2000, described at length in the last issue (14-3), it is considerably more flexible because it is programmable in BASIC. Like the LTS-2000, it can test op amps, d/a and a/d converters, regulators, comparators, etc., but the BASIC programming permits a wider range of test programs than are possible with fill-in-the-blanks programming.

Who can use the LTS-2010? Just about everyone who considers the specs of components to be important—including manufacturers, users, and test laboratories. Applications include incoming inspection—both simple GO/NO-GO testing and selection-and-grading—production testing, and engineering analysis. Because of its tremendous repertoire of test conditions, its ease of operation, and the number of ways in which it presents test results—as well as its inherent efficiency and accuracy—the LTS-2010 makes possible testing programs that before this could only have been dreamed about: they save time and money, and they reduce grief.

Like the LTS-2000, the LTS-2010 has an automatically self-calibrating 16-bit system accuracy. For high device throughput, the LTS-2010, like the LTS-2000, will interface with automatic component handlers, and it has available the same IEEE-488 and RS-232 communication interfaces. A strip printer, disk drive, keypad, function switches, and 40-character alphanumeric display are also inherent. ▀

*For technical data use the reply card.

SIX NEW MACSYM I/O INTERFACES Thermocouple Interface; Isolated Digital I/O IEEE-488; Analog Input; Digital Output; Interrupts

STB02 THERMOCOUPLE INTERFACE

The STB02-01,⁺ a 14-channel isothermal termination panel, interfaces thermocouples to MACSYM. A universal thermocouple interface, it will accept J,K,T,E,R, and S thermocouple types in any combination. For accurate measurement, a built-in cold-junction reference compensates the temperature readings through software.

Thermocouple types can be mixed and matched on the same board, and a single 16-slot ADIO chassis will measure up to 224 temperatures. Two available versions, the 14/28-channel STB02-01/02, are housed in a 19" mounting rack; 28 channels need only 2.71" of vertical space.

DIO-01 DIGITAL I/O INTERFACE

The DIO-01⁺ subsystem provides a complete, reliable solid-state optically isolated interface between MACSYM mainframe systems and control I/O applications involving power switching in noisy industrial environments. The subsystem consists of an ADIO interface card, an outboard I/O-module mounting rack, and an interconnecting cable. Each channel on the card is programmable as an input or output port by an on-board DIP switch. The external rack accepts up to 16 I/O modules, color-coded for ac/dc input/output. Power can be handled at 120V/280V ac (I/O), 60V/200V dc (O), or 10-32V dc (I). All output modules can withstand surges of up to 55A, peak (ac modules) or 5A (dc modules). Other voltages and special-purpose modules are also available.

ACP05 IEEE INTERFACE

With the ACP05⁺ interface card and its associated software drivers, MACSYM 2 can act as a Controller for instruments and peripherals that interface with the IEEE-488(1978) general-purpose interface bus (GPIB). The three types of devices on the bus are: Listeners (receive data from the bus), Talkers (transmit data to the bus), and Controller. With MACSYM 2 as Controller, in a fully expanded configuration, the ACP05 can handle up to 15 devices, performing as either Listeners or Talkers, or both (multiple Listeners and a single Talker at any one instant).

DOT03/04 DIGITAL OUTPUTS

The DOT03/04 Series⁺ of Digital Output Boards provide discrete contact closures for control of user processes. These ADIO cards are compatible with all MACSYM mainframe systems and provide direct discrete control for annunciator interfacing and switching of signals and low-power loads. The two versions differ only in relay-contact configuration. The DOT03 Series have 16 individually addressable Form "A" (SPST) reed relays with contact protection; the DOT04 Series have 16 Form "C" (SPDT) reed relays, available with optional contact protection. Form "A" reeds, rated at 10W(max) can switch voltages of up to 100V dc and currents to 0.5A; Form "C" reeds are rated at 3W (max) and can switch up to 28V and 0.25A. All relays are protected by Plexiglas covers and are installed in sockets for easy replacement or reconfiguration.

AIM03 ANALOG MULTIPLEXER

The AIM03⁺ Analog Multiplexer card handles up to 32 channels of high- or low-level signals from sensors, transducers, transmitters, and instruments. Five standard versions allow users to match the input configuration to the application. Elements of choice include single-ended or differential inputs (or both), and voltage ($\pm 5\text{mV FS}$ to $\pm 10\text{V FS}$) or current (0 to 20mA) inputs. The card can be scanned at a max rate of 4000 samples per second.

INT01/02 8-CHANNEL INTERRUPT

With the INT01 and INT02 8-channel Interrupt Priority Encoder cards,⁺ the MACSYM user can employ an external signal source to alter program flow in real time. The cards are available with isolation (INT01) and without it (INT02). The INT01 is for use whenever ground loops, high common-mode voltages, electrical noise, and other such error sources are common, typically in industrial environments. The INT02 is for more-benign environments. These cards sense priority events calling for immediate computer attention, even in mid-program segment, for example, alarm conditions, external triggers, and operator pushbutton signals. ▀

TRUE RMS-TO-DC CONVERTER Ideal for Battery-Powered Instruments No External Trims for Rated Accuracy

The AD636* is a monolithic true rms-to-dc converter with less than 0.5% error (AD636K), available in either a hermetically sealed 14-pin DIP or a 10-pin TO-100 metal can. Similar in operation to the long-popular AD536A (See *Analog Dialogue* 11-2, 1977), the AD636 is specified for a signal range of 0 to 200mV rms. Crest factors of up to 6 can be accommodated with less than 0.5% additional error, allowing the accurate measurement of complex waveforms.

As the block diagram of the device shows, the AD636 is complete on a single chip and requires only an external averaging capacitor to perform rms measurements with the specified accuracy. Both linear and dB outputs are available. The on-chip buffer amplifier can be used to buffer either the input or the output. At the input, it will buffer resistive attenuators; at the output, it will supply up to 5mA of output current.

The 200mV full-scale range of the AD636 is compatible with many popular display-

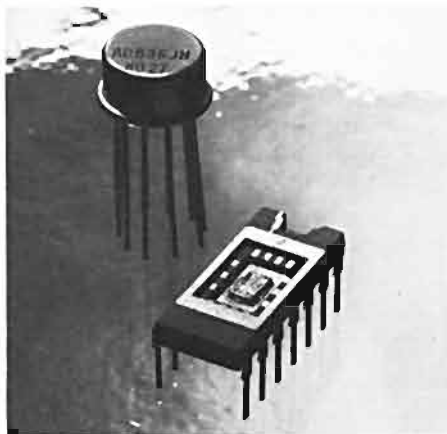

oriented analog-to-digital converters. Because of its low power-supply-current requirement—typically 800 μ A—it is useful in the design of battery-powered hand-held instruments. The circuit of a complete ac digital voltmeter, powered by a 9V battery, using an AD636, is shown below. The input attenuator provides an input range from 200mV to 200V full-scale.*

The AD636 will operate from either a bipolar or a single-polarity supply. In both packaging options, two versions are available (J/K), distinguished by performance. Total error, internally trimmed (for 0 to 200mV rms, dc or 1kHz sine-wave), is $\pm 0.5\text{mV} \pm 1\%$ of reading, max (J) or $\pm 0.2\text{mV} \pm 0.5\%$ of reading, max (K). The device is externally trimmable to within $\pm 0.1\text{mV} \pm 0.2\%$ of reading (K). Max tempco (K, 0°C to +70°C) is $(\pm 0.1\text{mV} \pm 0.005\%$ of reading)/°C. Bandwidth, for 200mV signals, 1% additional error, is 130kHz, and error within $\pm 3\text{dB}$, 1.3MHz. Prices (100s) are: \$5.95(J), \$9.95(K). \blacksquare

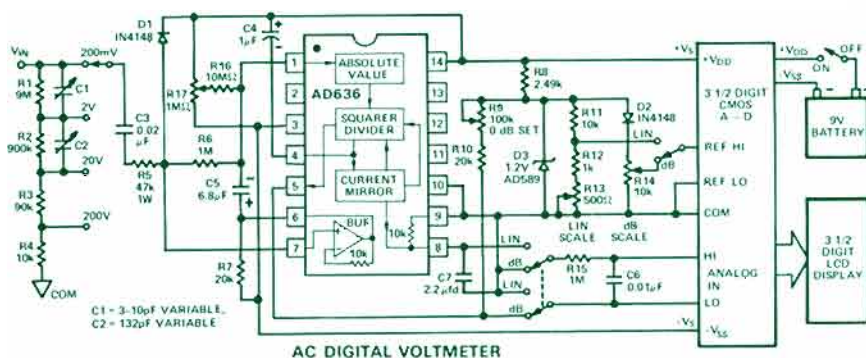
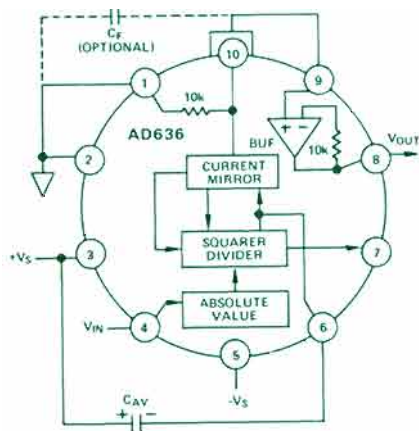

12-BIT ADCs In Hermetic DIP AD5200 Series

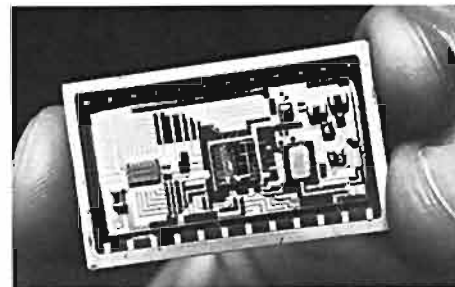

AD5200-Series Analog-to-Digital Converters are true-12-bit multi-chip converters, packaged in hermetically sealed 24-pin DIPs. Intended for applications in difficult environments, they are factory-trimmed for 12-bit operation with $\pm 1/2$ -LSB maximum nonlinearity and provide no-missing-code operation over the rated temperature range: -55°C to +125°C (T versions) and -25°C to +85°C (B versions). Processing to MIL-STD-883B Class B requirements is available for both the B and T versions.

The AD5200 Series are direct replacements for other devices of this type, providing significant improvements in performance. Since they are internally trimmed, they require no external adjustments. Both serial and parallel outputs are available. For higher reliability and reduced chip count, a monolithic d/a converter with proven performance is used in the successive-approximation circuit.

In addition to the temperature-range options, there is a choice of internal buried-Zener or external -10V reference, and a choice of input range: $\pm 5\text{V}$ or $\pm 10\text{V}$. Prices start at \$160 in 100s (AD5204B, AD5205B). \blacksquare

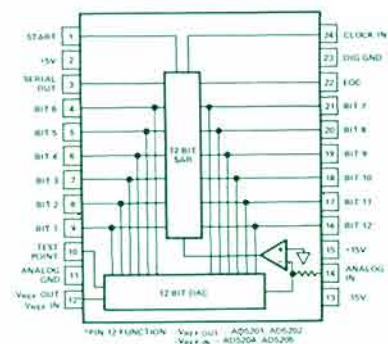

*For further technical data, use the reply card.

*Use the reply card for technical data.

HIGH-SPEED SOFTWARE-CONTROLLED GAINS

AD612/614 Can Be Used as μ P-Controlled Programmable-Gain Amplifiers This Circuit Does It with 4 Logic Chips and 2 Quad Switches

by Alan Jeffery

The AD612* and its high-speed version, the AD614 (see Table 1), described in these pages earlier (Vol. 14, No. 2) are hybrid differential instrumentation amplifiers that provide a choice of jumper-programmable gains from 1 to 1024, in binary steps. Figure 1 is a simplified schematic of these amplifiers, showing the nominal values of resistance in the gain-adjusting network. Because of their excellent stability and linearity, it is useful to consider the possibility of controlling the gain of these amplifiers remotely, using electronic switching. The design described here allows a microprocessor to control the gain in binary steps from 1 to 256.

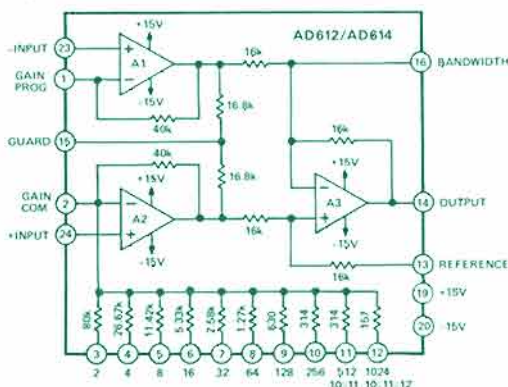

Figure 1. Simplified schematic of the AD612/614

Software control of gain makes it possible for microprocessor-controlled high-speed data acquisition and control systems to deal with signals having a wide dynamic range, either in a single channel, or among the signals applied to a number of input channels. The μ P can control the interface without the need of manual adjustments (via pin strapping, DIP switches, or thumbwheel switches) and even automatic gain ranging is possible to ensure that the level of an unknown signal is adequate to make best use of an a/d converter's input range.

In the circuit shown in Figure 2, the gain is selected by loading a 4-bit word (0000 to 1000) into the input port, which consists of a 7475 4-bit latch. The 74367 three-state buffers allow the μ P to read back the input data to check the gain setting.

Table 1.

	AD612	AD614
Small Signal Bandwidth (-3dB)		
G = 1	100kHz	100kHz
G = 128	60kHz	160kHz
G = 1024	10kHz	20kHz
Settling Time to 0.01% 20V p-p Output Step		
G = 1	200 μ s max	40 μ s max
G = 128	100 μ s max	30 μ s max
Settling Time to 0.05% 20V p-p Output Step		
G = 1 to 128	60 μ s max	20 μ s max
G = 1024	150 μ s max	70 μ s max

A 7442 decodes the 9 levels of input data and turns on one of the eight CMOS switches, which completes the circuit of one of eight of the gain-selection resistors in the AD612. When all switches are off (0000), the gain is unity. The gain is equal to 2^N , where N is the binary value of the input word.

The AD7511DI, with maximum R_{ON} of 100Ω , was used in this circuit. For gains up to 8, the value of R_{ON} in series with the gain-setting resistance contributes a gain error of less than 0.1%. For gains of 16 and above, the gain errors become more significant: the worst-case error at a gain of 256 is 25%! The error can be compensated for if the gain resistor is shunted by an appropriate value of resistance. This lowers the combined resistance by an amount equal to the increase due to the R_{ON} of the switch. In Figure 2, resistors R4 through R8 provide the required correction.

The nominal required values (to within 1-2%) can be calculated from the formula:

$$\frac{R_N}{R_{INT}} = \frac{\frac{R_{INT}}{80k\Omega}}{\frac{1}{G_0 - 1} - \frac{1}{G - 1}} - 1$$

where R_N is the required parallel resistance for the Nth gain input, G_0 is the measured gain, and G is the desired gain; R_{INT} is the internal gain resistance. Note that it may be possible to program the μ C to perform the gain measurement and automatically compute the approximate value of correction resistance.

R7 and R8 are used to null the output offset. Adjust R8 for zero offset when $G = 1$; adjust R7 for zero offset when $G = 256$. Readjust R8, if necessary, to insure minimum output offset voltage at each gain setting. ▀

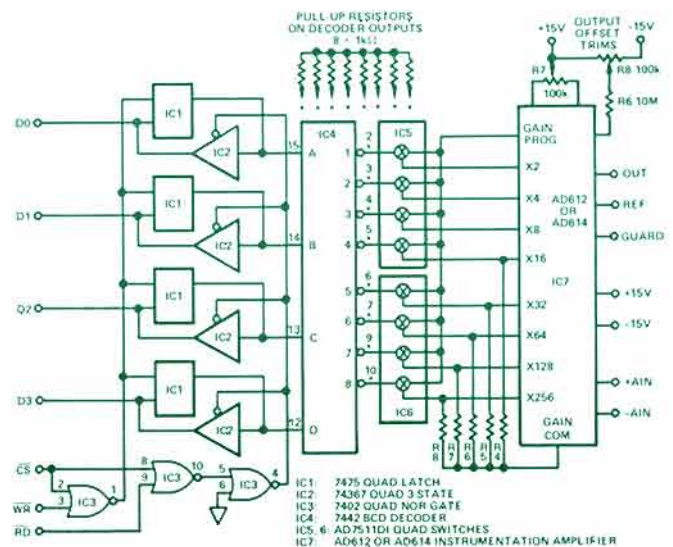

Figure 2. μ P-controlled programmable-gain amplifier circuit.

SYNCHRO & RESOLVER CONVERSION

Edited by Geoffrey Boyes, published in England by Memory Devices, a division of Analog Devices, 1980. 192 pages, 8½" X 11", \$11.50, ISBN 0-916550-06-0.



This is the *only* book available to treat in depth all aspects of the field suggested by its title, ranging from descriptions of synchros, resolvers, Inductosyns, and their variations to means of conversion back and forth from linear and rotary position to digital.

The chapter headings suggest the breadth of coverage:

- ONE Synchros and resolvers
- TWO Scott-connected transformers, the representation of angles in digital form, logic inputs and outputs
- THREE Synchro-and resolver-to-digital conversion
- FOUR Digital-to-synchro/resolver conversion
- FIVE Resolvers and Inductosyns in machine-tool and robot control
- SIX Related Conversion products
- SEVEN Applications

In addition, there are six appendixes:

- A Common synchro parameters
- B Synchro and resolver manufacturers
- C Harmonic distortion of the reference waveform
- D Speed voltages in resolvers and synchros
- E Vector-rotation algorithms
- F Effect of quadrature signals on servo systems

Order your copy from P.O. Box 796, Norwood, MA 02062. Use the enclosed card, or send check or Master-Charge information.

HIGH-RESOLUTION PRODUCTS

The *Designer's Guide to High-Resolution Products* is a useful 18-page guide to parameters, testing, specifications, applications and selection of high-resolution converters, plus the parameters and specifications of sample-holds and V/f converters.

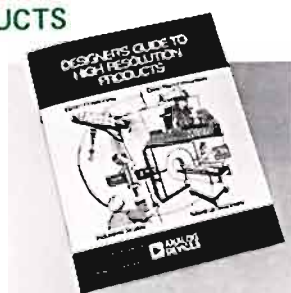

Available FREE — Use the reply card.

SIGNAL-CONDITIONING- PRODUCT GUIDE

Subtitled *How to Optimize the Transducer-to-Computer Interface in Data-Acquisition Systems*, this six-page guide presents brief but forceful arguments for "buy" rather than "make" when it comes to signal conditioners, and provides a quick overview of Analog Devices signal conditioners and 4-to-20mA current transmitters.



Available FREE — Use the reply card.

MORE AUTHORS (continued from page 2)

Ronald P. Knapp (p.12), a Design Engineer in ADI's Micro-Electronics Division, has a B.S. in Systems Engineering from Boston University and an MSEE from Worcester Polytechnic Institute and is a member of ISHM and IEEE. He has been a Design Engineer at Unitrode and a Product Engineer in ADI's Semiconductor Division. Products he



designs include hybrid high-speed a/d and d/a converters and precision voltage references.

Alan Jeffery (page 17) is a participant in the Analog Devices Rotational Training Program. Graduated from Northeastern University with a BSEE, his first assignment was in the System Component Division. Currently, he is with the Measurement and Control Products Division, designing an isolated BCD input card for MACSYM.



Across the Editor's Desk

MORE ABOUT TRACK-HOLD (T-H) TIMING ERRORS

In *Analog Dialogue* 14-2, we mentioned a reader's assertion that tracking phase lag is sometimes as serious a source of error as aperture delay. Jack Memishian, taking us to task for agreeing too readily with the reader's argument, asked us to stress *sometimes* and urged a more-thorough discussion lest readers be led to mistrust or overspecify T-H's unreasonably.

If a 14-bit T-H has 50ns aperture delay time and 0.5ns aperture uncertainty (τ_{au})—because of time jitter of the switching logic—the maximum frequency that can be sampled with less than 1/2-LSB error is $2^{-(n+1)}/(\pi\tau_{au})$, or 19.4kHz, because of the irreducible uncertainty of time position from sample to sample. Since the 50ns delay time is the same for every sample, it is unimportant for ensembles. For unique events, or where phase between two channels is critical, the delay can be nulled out, to within τ_{au} , by a timing adjustment of the *sample* strobe.

Phase lag in the analog signal path (ϕ_s) is quite a different matter. Suppose that a T-H with a 1MHz single-pole rolloff is sampling a 20V p-p 20kHz sine wave. For a sample at the zero crossing, the output should (ideally) be 0V; but, ϕ_s causes the output of the T-H to be almost 400mV! Is the error therefore an irreducible 2%? Not at all. A check of other points of the waveform shows the error to be a well-behaved cosine term representing a proportional amplitude error of 0.0017dB (0.02%), with 1.15° phase shift—the same errors caused by a 1MHz rolloff anywhere in the input signal path.

The 400mV zero-crossing "error" is simply an amplitude measure of a 1.15° phase shift. But a one-shot measurement to high accuracy at a *single* waveform point must have a measurement bandwidth implied by the desired *time* resolution, rather than an ensemble bandwidth. For example, a 14-bit-accurate *one-time* measurement at the zero crossing of a 20kHz sine wave requires a 667MHz channel bandwidth—plainly beyond the range of general-purpose T-H's—although, as shown above, their performance is quite adequate for their intended purpose.

An Eclectic Collection of Miscellaneous Items of Timely and Topical Interest. Further Information on Products Mentioned Here May Be Obtained Via the Reply Card.

IN THE LAST ISSUE (Volume 14, No. 3, 1980) . . . LTS-2000 Linear Test System: Computerized Test System for Linear Devices; Versatile System Console for Accurate Measurement; System Software Designed for Unskilled Operators; Software-Configured Family Boards Speed Testing; Sample Programs for Testing Op Amp and D/A Converter . . . and these New Products: 12-Bit 16-Channel Hybrid Data-Acquisition System (AD364); 12-Bit 40ns ECL D/A Converter (HDS-1240E); 8-Bit 8-Channel DAS with Bus-Addressable RAM on a Single Chip (AD7581); Improved IC Op Amp (AD OP-07); 12-Bit Serial-Input Monolithic DAC (AD7543); Temperature Transmitter, AD590 to 4-to-20mA (see pp. 8-9, this issue - 2B57); Fast Hybrid Op Amp (ADLH0032) and Buffer (ADLH0033) Families; 8-Bit 9-Channel CMOS A/D Converter Subsystem on a Single Chip (AD7583); Deglitched 8/10-Bit D/A Converters (HDD Series) . . . Analog Devices Names Division Fellow: Jack Memishian . . . Plus, Authors, Potpourri, etc.

ERRATA AND UPDATES . . . AD578 Technical Data (C598-9-10/80): In Figures 3, 4, 8, 9, REF OUT (pin 24) should not be grounded. First, the circuits won't work as described; second, the reference is stressed. Also, in the Specifications, where TTL loads are mentioned, we meant low-power Schottky TTL . . . The RTI-1220/1221 are compatible with Pro-Log PLS and MPS Series, not the Series 7000 (STD Bus); for Series 7000 and Mostek MD, use the RTI-1225 . . . In data sheets for the AD7542 and AD7543, the chip size should be $0.096(2.438) \times 0.134(3.403)$; the underscored digits were interchanged . . . Any items labeled "actual size" or 1:1 scale on data sheets will appear reduced in the smaller Data Acquisition Components and Subsystems Catalog; this is true of the PCB layouts in Figures 5a and 5b of the AD7555 data sheet, which should be used instead of the illustrations on page 10-63 of the Catalog . . . A tip-in Errata sheet is available to replace the 612 Specifications on page 2-18 of the Catalog. Better yet, ask for the more-complete and up-to-date AD612/AD614 Programmable-Gain Instrumentation Amplifier data sheet.

U. S. TRADE SHOWS . . . We are planning major participation in the following U.S. shows during 1981. If you're in the vicinity, come in and visit us: . . . Instrument Society of America, March 23-26, in St. Louis, MO . . . ELECTRO, April 7-9, in New York City . . . WESCON, September 15-17, in San Francisco CA . . . Instrument Society of America, October 6-8, in Anaheim CA . . . MTDCON, November 10-12, Chicago IL.

NEW DATA SHEETS . . . A new AD580 (2.5V Reference) data sheet is available, featuring new, improved performance. Ask for AD580 data sheet C549-9-3/80.

APPLICATION NOTES . . . When MACSYM 20 is used with the HP85 as host computer, you don't necessarily require an IEEE-488 communication link, since the HP85 has optional 20mA current loop and RS232 interface modules. Consult your MACSYM Sales Engineer to determine the appropriate HP hardware complement . . . Consult your MACSYM Sales Engineer about MACSYM hardware and software training courses, an inexpensive way to become familiar with MACSYM hardware and MACBASIC programming before you actually buy your MACSYM . . . Our application engineers have discovered a new, low-cost Schottky diode - the HSCH-1001 (also known as IN6263), from Hewlett-Packard; U.S. prices through Schweber are 39¢ in 100s, 27¢ in 1000s. Schottky diodes are used for clamping because they exhibit lower forward voltages than normal silicon junction diodes (about 0.3V vs. 0.6V); they begin to conduct before parasitic diodes or SCRs in bipolar or CMOS ICs turn on . . . You can buy a Teflon fitting for use with the AC2626 temperature probe, similar to the brass or stainless compression fittings now available, from CHEMPLAST, Inc., 150 Dey Road, Wayne NJ 07470, their model TMP S-0402FK. Max pressure rating at 150°C is 55 psi . . . You can interface remote transducers to any of the standard microcomputer buses by transmitting 4-to-20mA current information to the appropriate RTI real-time microcomputer-interface card. How do you get 4-to-20mA current information? See pages 8-9, this issue . . . A short 1-page Application Note compares the results of dynamic-stability measurements on our AD589 and a couple of other popular 1.2V references, as a function of reverse current and capacitance. The AD589 is a clear winner. Ask for "On the Stability of 1.2V References," by Doug Grant . . . The 2B20 voltage-to-4-to-20mA converter can be easily connected for a 0-to-20mA output range. A connection diagram is available from your ADI Sales Engineer . . . Turn-on latchup in occasional 2B31 signal conditioners in the current-supply mode can be avoided entirely by connecting a 24k Ω resistor between pins 17 & 21 and a 1N914 diode pointing from pin 21 to pin 22 (a modification to such suggested circuits as Figure 7 on the 2B31 data sheet).

PRODUCT NOTES . . . Each 18-bit DAC-1138 is shipped with a Linearity-Verification Record, containing the results of tests using equipment and methods traceable directly to the National Bureau of Standards . . . If you're using DDC synchro/resolver-to-digital converters, you may be interested in seeing a chart that lists ADI equivalents. Call your local ADI sales office . . .

REPRINTS AND LITERATURE AVAILABLE . . . "DAS Packs Memory for Easy μ P Interface," by Hans Tucholski and John Wynne, *Electronic Design*, Sept. 13, 1980: all about the AD7581 . . . "Software Noise Filters in MACBASIC," a brief MACSYM Application Note . . . "RTI Series Feature Guide": A brief one-page summary selection guide to choosing the appropriate RTI for your microcomputer bus and I/O requirements.

NOW THAT YOU'VE GOT A REAL CHOICE IN OP-07'S, THERE'S REALLY NO CHOICE.

A SECOND SOURCE THAT'S REALLY SUPERIOR.

The long wait for the second source OP-07 that's reliable, dependable and readily available is over! The Analog Devices new AD OP-07 op amp is clearly in a class by itself. It offers ultra-low offset voltage, low input current, low noise and low drift. It has ten times more open-loop gain than the competition, so it provides far greater accuracy and linearity in high closed-loop gain applications. Our AD OP-07 comes in the five standard performance grades — three commercial, and two MIL.

COUNT ON US FOR CONSISTENT DELIVERY, TOO!

When you tell us what you want and when you want it, we'll give you a delivery commitment you can count on



every time. And with a full line of precision op amps to choose from, we can deliver the exact op amp you need.

SO WHAT ARE YOU WAITING FOR?

If you've been waiting to design in the OP-07, or if you're already using it in your designs, now you've got a better way to go. It's the new AD OP-07 from Analog Devices.

For more information on the AD OP-07, contact Doug Grant or Don Travers at (617) 935-5565, or write Analog Devices, Inc., P.O. Box 280, Norwood, MA 02062.



*THIS OP-07
DOESN'T COME
FROM FANTASYLAND!*

 **ANALOG
DEVICES**

WAY OUT IN FRONT.

Analog Devices, Inc., Box 280, Norwood, MA 02062; East Coast: (617) 329-4700; Midwest: (312) 894-3300; West Coast: (714) 842-1717; Texas: (214) 231-5094; Belgium: 031/37 48 03; Denmark: (02) 84 58 00; England: 01/94 10 46 6; France: 687-3411; Germany: 089/53 03 19; Japan: 03/26 36 82 6; Netherlands: 076/879 251; Switzerland: 022/315760, and representatives around the world.