

analog dialogue

A forum for the exchange of circuits and systems for measurement and control

PUTTING THE AD558 COMPLETE 8-BIT IC DAC ON THE BUS (Page 16)

Isolate, Amplify, Multiplex Four or More Channels of Analog Data (Page 3)

Complete Contents on Page 3

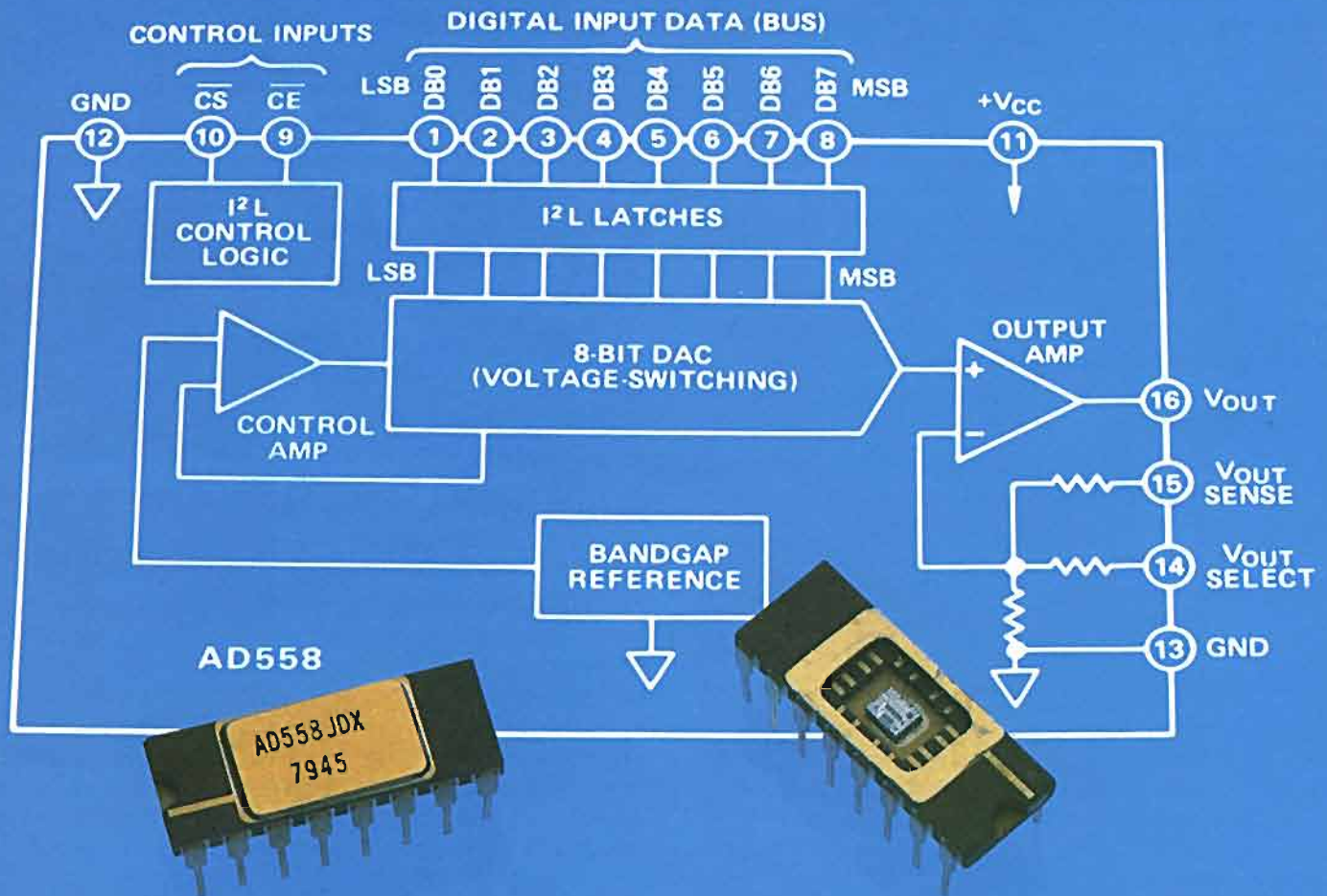

Editor's Notes

WHAT'S NEWS?

These days, the media seem more impressed by quantitative aspects of innovation than by qualitative rotations of the direction of progress. One tends to read much about progress towards the expected (the 64K RAM, Very Large Scale Integration, Very High Speed Integration), that is to say, linear extrapolations (more, better, faster, cheaper). Now, it is certainly not for us to gainsay the very real progress that underlies this kind of improvement. We have contributed our own share of innovations that make for progress in an expected direction.

However, there are other innovations whose impact is a little more subtle, because their real contribution is not a dramatic step forward in one aspect of performance. Rather, it is in the advantages that are provided to the user who is willing to understand what they are about and—in recognizing possible multidimensional gains—is willing to take a step in an uncharted direction.

In scanning the table of contents for this issue, it occurred to us that there are a number of good examples of such advances in this small slice of technology at this one instant of time.

Certainly the device that graces our cover is not intrinsically glamorous. It's just an 8-bit DAC, 1-part-in-256 resolution. Ah, but what a DAC! On a single chip, *everything* that is needed to grab an 8-bit byte and provide a correct analog output voltage is there. Included are latches, reference, resistors-and-switches, and output amplifier—and the entire device operates from a single +5V microcomputer power supply!

Or, as long as we're looking at DACs, consider the DAC1423 on page 6. It's just a 10-bit DAC, 1 part in 1024 resolution. What's so special about it? *Everything*. First of all, it's 1000V-rms isolated. Next, its output is 4-to-20mA. Also, it's read-write memory: the bus can either write to it (update the output) or read the value that is currently latched. And the list goes on. The upshot—a process engineer's dream direct-digital-control component.

We can't leave the subject of DACs without mentioning two others that represent qualitative progress: the 12-bit CMOS AD7542 (page 9), a small, low-cost, reliable device with *only 16 pins* (it's not only low-cost to buy, but to use as well), that interfaces via three 4-bit nybbles; and the AD7110 digitally controlled *audio attenuator* (page 7): it adjusts gain in increments of 1.5dB/bit, from 0 to -88.5dB, has full muting and switches for loudness compensation.

But it's not just DACs that are really new: How about the all-electronic isolated amplifier-filter-multiplexer that appears to present a real challenge in performance to flying capacitor systems? Or the cold-junction compensator that handles up to four types of thermocouple, digitally programmed (page 5)? Or the new approach to component testing represented by the LTS-2000 (page 10)? These are the kinds of things that impress *this segment of the media*. ▀



Dan Sheingold

THE AUTHORS



Lockheed, Westinghouse, etc. His present activities include technical training, trade shows, editing, and writing.

Dr. Malcolm "Steve" Stephenson (page 7) is Senior Applications Engineer at ADBV. Previously, he lectured at Trinity College (Dublin) for a number of years, and he consulted on ultrasonics and basic instrumentation. He was graduated from the University of Surrey (England), where he also took postgraduate work towards his doctorate. He maintains deepening ties with the faculty of the National Institute of Higher Education in Limerick.



John Wynne (page 9) is an Applications Engineer at AD BV (Limerick, Ireland). Previously, he was Telecommunications Project Engineer in the City of Dublin Kevin Street Technical College, and later a Design Engineer at Sperry Gyroscope Avionics Division U.K.



Doug Grant (pages 16, 17) Micro-circuits Applications Engineer at Analog Devices Semiconductor, has a BSEE from Lowell Technological Institute and is currently working on an MSEE. He has worked in converter development at Hybrid Systems, and μ P-based data-acquisition systems and analytical instrument interfaces at Adams-Smith, Inc; he joined Analog Devices in 1976 as a Design Engineer. Doug is active in Amateur Radio.



analog dialogue

Route 1 Industrial Park, P.O. Box 280, Norwood, Mass. 02062

Published by Analog Devices, Inc., and available at no charge to engineers and scientists who use or think about I.C. or discrete analog, conversion, data handling and display circuits. Correspondence is welcome and should be addressed to Editor, *Analog Dialogue*, P.O. Box 280, Norwood, Massachusetts, U.S.A. 02062. Analog Devices, Inc., has representatives and sales offices throughout the world. For information regarding our products and their applications, you are invited to use the enclosed Business Reply card, write to the above address, or phone 617-329-4700, TWX 710-394-6577 or 710-336-0562, Telex 924 491, or cable ANALOG NORWOODMASS.

ISOLATE, AMPLIFY, MULTIPLEX 4+ CHANNELS

Low- or High-Level Signals from Thermocouples and other Sensors A New Approach to Expandable Multi-Channel Signal Conditioning

by Frank Goodenough

Models 2B54 and 2B55* are four-channel complete signal conditioners that accept low- or high-level dc inputs from transducers, provide resistor-programmable adjustable gain for each channel, and select the output determined by one of four decoded digital control signals. All four channels are transformer-isolated from one another and from the output ($\pm 1000V$ peak max), and their outputs are optically isolated from the control signals. The input circuits are protected against normal-mode voltages up to 130V rms @ 60Hz.

The 2B54 has a low-drift input circuit ($1\mu V/^\circ C$ max for 2B54B), intended for thermocouples and other low-level sources, with an adjustable span range (for $\pm 5V$ output) from $\pm 5mV$ to $\pm 100mV$. The 2B55 provides a ± 5 -volt output span for input spans from $\pm 50mV$ to $\pm 5V$. The block diagram of Figure 1 shows an example of the variety of input sources (with their individual "grounds") that can be safely applied to a single 2B54/55 continuously, reliably, rapidly (400 channels per second), and at low cost (\$36/channel, 2B54A in 100s).

The selected analog output is buffered by an amplifier, with a remotely sensed feedback terminal. A digitally switched expansion output provides for the multiplexing of additional 2B54/55 outputs *without the addition of external analog switches*. When thermocouples are used, a companion model, the 2B56,* provides the system with switched ambient (cold)-junction compensation¹ for up to 4 different TC types (page 5).

to the problem of isolated multi-channel signal conditioning: less costly than existing packaged solutions, far more convenient than (and competitive in cost with) user-designed equipment, and a distinct improvement over flying-capacitor systems.

BACKGROUND

The role these devices were designed for is an extremely difficult one. First, they must be capable of resolving submillivolt changes in the presence of large common-mode voltages, with low drift and nonlinearity. The common-mode voltage may be present on the signal's ground, or it could be induced in the input leads inside a conduit in the vicinity of high-power mains. The signal itself may be afflicted with normal-mode noise.

Safety is a paramount consideration. The devices must be able to withstand high common-mode voltages without damage, and without exposing the equipment the output is connected to to high voltage. By the same token, the inputs must be able to withstand the accidental connection of line voltage across any pair of input terminals without mishap. Finally, if the input should be *open-circuited* due to failure of a sensor, an appropriate indication should be given, since false information can cause system safety problems.

It should be possible to handle signal diversity without intro-
(continued on the next page)

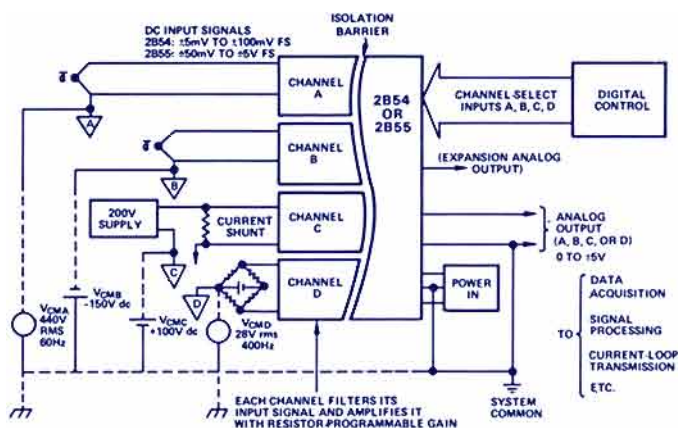

Figure 1. 2B54 and 2B55: What they do

The 2B54 and 2B55, having no relays or other moving parts, provide versatile, quiet, reliable analog data acquisition for industrial measurement-and-control systems, with outputs at standard levels for a/d conversion systems, meters, recorders, and 4-to-20mA signal transmitters (such as the Analog Devices Model 2B22). They are intended to be the definitive solution

*For technical data, use the reply card.

¹The electrical properties and applications of thermocouples and other popular transducers are discussed in some detail in the *Transducer Interfacing Handbook—A guide to analog signal conditioning*, a 266-page hardcover book (1980) available for \$14.50 from Analog Devices, Inc., P.O. Box 796, Norwood MA 02062.

IN THIS ISSUE

Volume 14, Number 2, 1980, 20 pages

Editor's Notes, Authors	2
<i>Isolate, Amplify, Multiplex 4+ Channels (All Solid State)</i> . . .	3
<i>Programmable Cold-Junction Compensator (4 Different TC's)</i> .	5
<i>Isolated Conversion from Digital to 4-to-20mA</i>	6
<i>0 to -88.5dB in 1.5dB Steps (Digital Attenuator)</i>	7
<i>10-Bit 20MHz Video A/D Converter</i>	8
<i>12-Bit CMOS M-DAC Interfaces Directly with μPs</i>	9
<i>Computerized Test System for Linear Devices (LTS-2000)</i> . .	10
New-Product Briefs:	
Hybrid 12-Bit S/D converters (SDC1741/1742)	11
4 1/2-5 1/2 Digit ADC Subsystem on a Chip (AD7555)	11
Fast A/D Converter Modules (MAH-0801, -1001)	11
Data-Acquisition Analog Front End (AD362)	12
Fast Hybrid A/D Converter - 12 Bits in 4 μ s (AD578)	12
Improved Op Amp with 1.2X10 ⁶ min. gain (AD OP-07)	12
MACSYM: 3 Input Cards - Isolation, Frequency, Bridges	13
Lowest-Cost Isolators, Stand-Alone & Synchronizable	14
Pin-Programmable Hybrid Instrumentation Amplifier (Binary gains, 1 to 1024 - Model AD612)	14
μ P-Compatible 8-bit ADC Interfaces Like Memory	14
Application Briefs:	
<i>DAC Controls Precision UHF Noise Level</i>	15
<i>Putting the AD558 8-Bit DACPORT™ On the Bus - Interfacing to μPs with One Easy Chip</i>	16
New Literature: 1980 Short-Form Guide, MACSYM 2 <i>System Digest, Transducer Interfacing Handbook</i>	18
Across the Editors' Desk: ΔT , Sample-Holds	18
Potpourri	19
Advertisement: High-Speed Hybrids	20

ducing complexity, whether the signals are millivolt signals from different thermocouples requiring different scale factors or mixtures of millivolt signals from strain gages and volt-level signals from potentiometers and current-transmitter loops.

Among other requirements, it is desirable that an arbitrary number of channels be monitored, and that the system be expandable, because there is invariably a need for "one or two more" channels than planned for.

These conditions are, and have been, difficult to meet at reasonable cost. Successful approaches have been (a) to use individual isolation amplifiers for each channel, with appropriate gains, and perform the multiplexing at high level (this solution can be expensive if there are many channels); (b) to use "flying capacitor" techniques, illustrated in Figure 2. Here, capacitors are switched—generally by relays—between the signal sources and the inputs of the system; this provides isolation and multiplexing, but it is not easily adaptable to individual-channel gain adjustment. While not necessarily costly in terms of parts, this approach can be complex, resulting in a custom installation at high overall cost, with a substantial software overhead for calibration of individual channels. It is also potentially noisy, and common-mode range is limited by the voltage ratings of the capacitors and switch contacts; speed and life are limited.

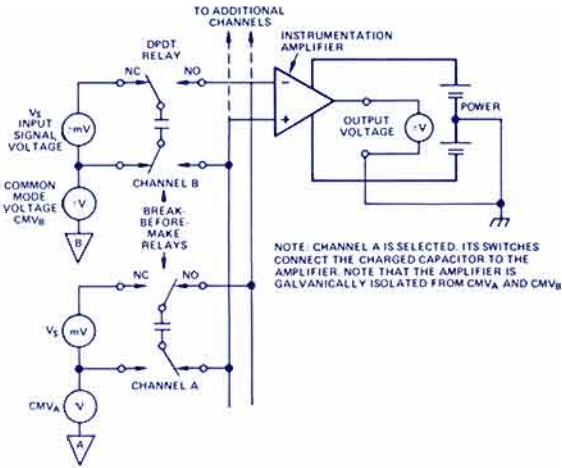

Figure 2. Example of flying-capacitor multiplexer.

In the case of the 2B54/55, the complexity is almost entirely contained within the 2"X4"X0.4" (51X102X10.4mm³) module (Figure 3), and the cost is a known per-channel quantity. Isolation is provided by proven transformer-coupling techniques, long a forte of Analog Devices, and the all-electronic multiplexing is performed within the device. Isolated power is provided to the four amplifiers by an externally synchronizable power oscillator. The amplified input signal chosen is transmitted across the isolation barrier, synchronously demodulated, and buffered by the output amplifier. If a single 2B54/55 is used, the output is taken from the DIRECT output. If more than one 2B54/55 (in any combination) is involved, the SWITCHED output is used, controlled by the ENABLE input.

Note that the filter at the input of each amplifier has 55dB min normal-mode rejection at 60Hz (gain of 1000). The gain of each amplifier is set individually by the choice of an externally connected resistor. A small amount of isolated \pm dc voltage is available with each amplifier for offset trimming, where necessary. The common-mode rejection is 156dB min at $G = 1000$ (50Hz, 100 Ω unbalance). An open input circuit is

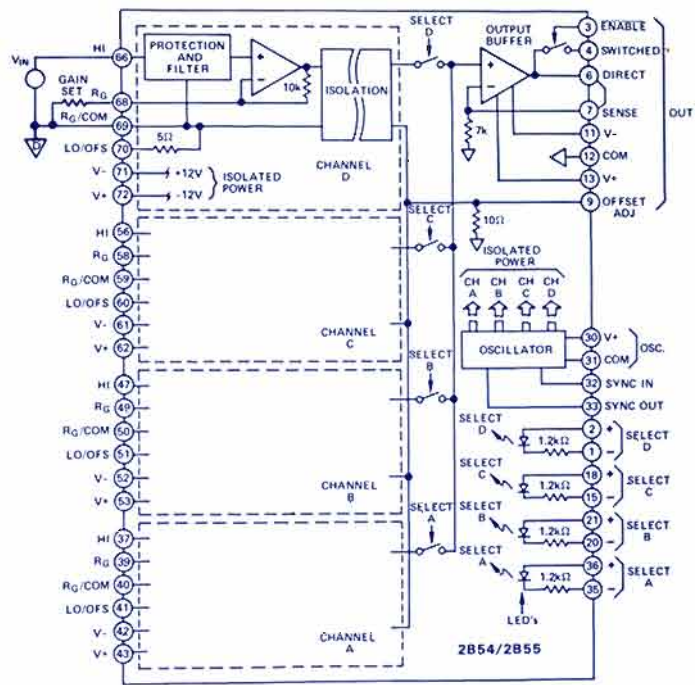

Figure 3. 2B54/2B55 Functional Diagram.

indicated by output at negative overscale, about -7V.

MULTIPLEXING UP TO SIXTEEN CHANNELS

Figure 4 shows a multiplexing scheme with 4-bit addressing, to read the outputs of up to four 2B54/55s, i.e., 16 channels. The SWITCHED (expansion) outputs are connected together; the analog output bus is driven by the device that is enabled, in an analog version of three-state switching.

As the figure shows, the 4-bit binary channel address is decoded by a 74LS139 dual 1-of-4 demultiplexer. The state of inputs 1A and 1B determines which channel is selected, and the state of inputs 2A and 2B determines which device is enabled.

Further expansion is practicable without increased complexity, as long as the SELECT bus does not overload the decoder(s). The optional analog buffer, which unloads the 35 Ω expansion outputs, may be either an op amp or a sample/track-hold (if the output is to an a/d converter).

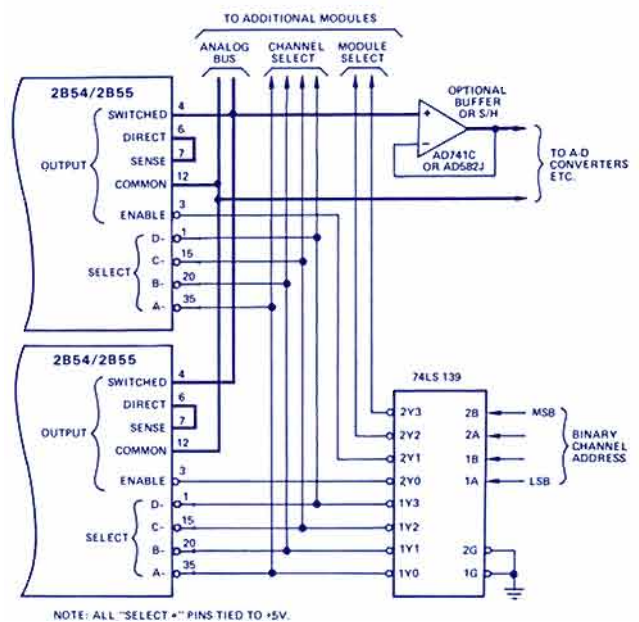

Figure 4. Expansion to more than four channels.

2B56 PROGRAMMABLE COLD-JUNCTION COMPENSATOR

Digital Switching Selects References for 4 Different Thermocouples $\pm 0.8^\circ\text{C}$ Reference Temperature Error for 5° to 45°C Ambient Range

by Frank Goodenough

Model 2B56* corrects the analog signal derived from a thermocouple (TC) for the error due to non-zero temperature at the reference junction. It does so by deriving a correction signal from the output of a user-supplied electrically insulated sensor at the same temperature as the reference junction, and combining it with the thermocouple's output signal.

As Figure 1 shows, the 2B56 performs this operation at high level; it can therefore be applied to systems with instrumentation or isolation amplifiers already in place. In multiplexed systems using different thermocouples, one of its four different compensation characteristics is chosen by a 2-bit digital control signal—which can be encoded to agree with the address of the input being read. The 2B56 is therefore an ideal partner for 2B54 multiplexed isolation amplifiers when the inputs are TCs.

Type	At 1200°C		At 400°C		At $+25^\circ\text{C}$	
	V_T mV	$\Delta V_T/\Delta T$ $\mu\text{V}/^\circ\text{C}$	V_T mV	$\Delta V_T/\Delta T$ $\mu\text{V}/^\circ\text{C}$	V_T mV	$\Delta V_T/\Delta T$ $\mu\text{V}/^\circ\text{C}$
B	6.78	10.4	0.79	4.0	-0.002	0.1
E	—	—	28.9	80.0	1.50	60.9
J	69.54	57.2	21.85	55.2	1.28	51.7
K	48.83	36.5	16.40	41.9	1.00	40.5
R	13.22	13.9	3.41	10.4	0.14	5.9
S	11.95	12.0	3.26	9.6	0.14	6.0
T	—	—	20.87	61.8	0.99	40.7

Relative errors due to the magnitude of V_{T2} (at $+25^\circ\text{C}$) at the cold junction range up to a couple of percent for 1200°C measurements, and increase rapidly below 400°C . For all but Type B, each degree of ambient change results in an incremental error of from about $1/2$ to 1°C in the reading.

A practical alternative for greater accuracy is to measure the temperature at the reference junction, develop a voltage equal in magnitude and tempco to the predictable reference-junction characteristic, and use it to provide *cold-junction compensation (CJC)*, which differs from type to type.

The 2B56 has digitally programmable fixed compensation for popular Types J, K, and T thermocouples; the properties of the fourth (X) compensation channel may be established by the user, including compensation for any of the other types or no compensation (a useful feature if the 2B54 is multiplexing other low-level sources, such as bridges or RTDs).

In Figure 2, The 2B56 reads the chosen output from a pair of 2B54s (see pp. 3 & 4), provides compensation appropriate to the input device, and has a gain of 2 for a 10V output range. The CJC ambient-temperature sensor may be an AD590 IC absolute temperature sensor, or it can be a 2N2222 transistor connected as a diode. The digital input to the Type Select control is programmed to provide the proper coding for the required compensation as the channels are switched (00, 01, 10, 11 give J, K, T, X).

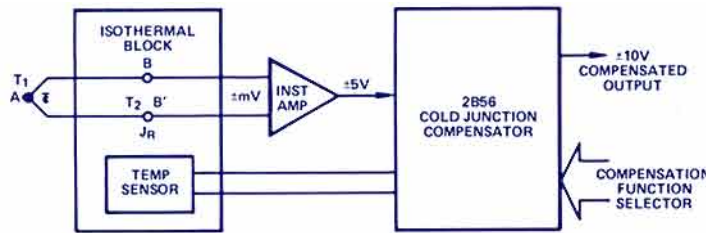

Figure 1. 2B56 simplified application diagram.

WHAT IS COLD-JUNCTION COMPENSATION?

More than half of all physical measurements involve temperature. In industrial and military instrumentation, most temperature measurements are made with thermocouples. The thermocouple, consisting of two wires made of different materials in contact at one point, is cheap, small, covers a wide temperature range, and has been in widespread use for a long time; data for seven standard types is widely available. It does have a few problems: the output is in the millivolts (typical tempcos are in the 4 to $80\mu\text{V}/^\circ\text{C}$ range), the output of most types is noticeably nonlinear, and the output indicates a temperature difference, rather than the temperature at a given location.

If the ends of a length of wire are at different temperatures, there will be a voltage difference, the magnitude depending on the composition of the material. If two wires of different material are in contact at one end (A: T_1), and at identical temperatures at the other ends (B, B': T_2), the output voltage will depend on the temperature difference, $T_1 - T_2$. The thermocouple tables are predicated on $T_2 = 0^\circ\text{C}$; classically, such measurements have been made in the laboratory using an ice bath—not very practical for a missile or a mountaintop.

Another alternative is simply to leave the reference ("cold") junction at its ambient temperature and hope the voltage due to ambient and its changes is negligible compared to the voltage due to temperature at the active junction. How well this might work can be seen in the table:

*For technical data, use the reply card.

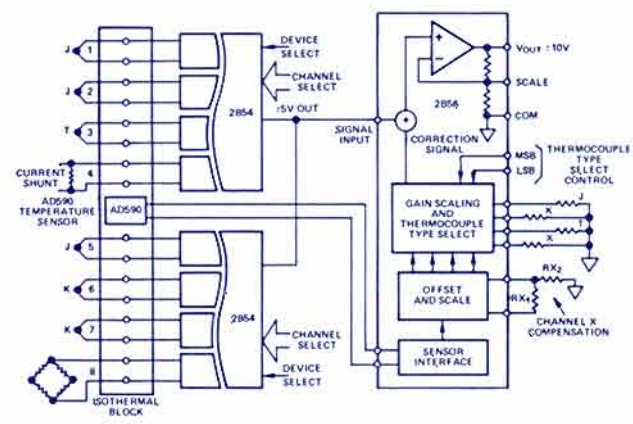

Figure 2. 2B56 cold junction compensator operating with a pair of 2B54 isolated multichannel amplifiers.

ISOLATED CONVERSION FROM DIGITAL TO 4-TO-20mA

μ P-Compatible 10-Bit DAC1423 Uses Loop or Independent Supply Has Readback Capability, Can Operate Manually When Computer Is Down

PROCESS-CONTROL D/A CONVERTERS

In the last issue,* we described a series of Loop DACs with analog output in the form of a standard 4-to-20mA current (DAC1420 and DAC1422*). Specifically designed for process control applications, these DACs provide a 4-to-20mA output current with a span directly proportional to the digital word latched at the input. That is, all-zeros produces 4mA of output current, all-ones produces 19.98mA (10-bits), and intermediate codes produce proportional outputs. Alternatively, as a backup, the output can respond to an analog voltage input, with automatically switched mode if the computer fails. The DAC1420 and 1422 are direct-coupled and are not designed to operate in the presence of high common-mode voltages. The new DAC1423 ISO-DAC™ is specifically intended for applications where isolation is called for.

The DAC1423* as Figure 1 shows, produces a 4-to-20mA output current in response to a 10-bit binary digital signal provided via a latched 10-bit counter. The data, which might represent the desired setting of an actuator, is normally latched in from an 8- or 16-bit data bus, in response to a WRITE command. The digital word is converted to an analog signal, which is transmitted across an isolation barrier (via a modulated carrier), demodulated, and converted to a current signal with a 4mA offset and a 16mA span.

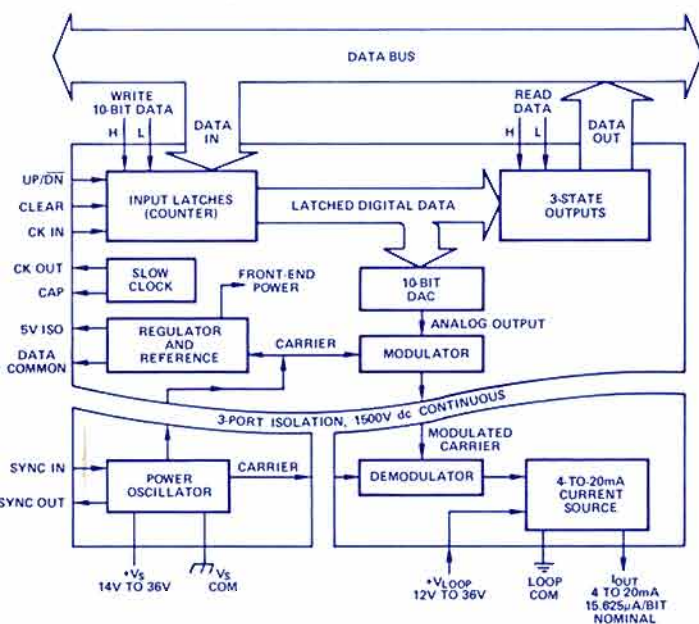

Figure 1. Block diagram of the DAC1423.

"BUMPLESS TRANSFER"

The DAC1423 provides for preservation of the last setting and independent operation if—for any reason—useful data is not available from the bus. Under such conditions, pulses applied to the CLOCK input of the counter, while the UP/

*For technical data on any of these devices or a copy of Analog Dialogue 14-1, use the reply card.

DOWN input is 1 or 0, will increase or decrease the number stored in the register (and hence the analog output), one bit at a time. The pulses may be applied by manual switching or by an external backup processor, or gated in from an on-board slow clock generator.

As Figure 1 shows, there is also a three-state data-output register, which can place the information stored in the latches on the bus in response to a READ signal. This facility, which makes the DAC1423 look like READ/WRITE memory, permits the computer to learn the state of the device (and the parameter it actuates) at any time—and especially when computer control is resumed after an off-the-bus period. A CLEAR input permits the latches to be set to zero, e.g., during startup.

The latches and three-states are in the form of two bytes with separate controls, a 2-bit right-justified HIGH byte and an 8-bit LOW byte. In 16-bit-bus operation, the byte controls are tied together; on an 8-bit bus, the controls are operated separately (but usually rapidly in sequence) to multiplex the latches.

1500VDC 3-PORT ISOLATION

As Figure 1 shows, the DAC1423 has three divisions ("ports"), galvanically isolated from one another with a breakdown rating of 1500V dc continuously or 1000V rms ac at line frequency for one minute. This is more than adequate for most process applications. The three sections can be termed: power, output, and front end. The power section contains a synchronizable high-frequency oscillator, the output of which is transformer-coupled to the other sections. The front end has a regulator and reference, a CMOS d/a converter, a modulator with transformer-coupled output, the slow clock for off-bus application, and the digital logic circuitry. Also available is a small amount of power at 5V dc for external devices, such as logic gates for external drive in off-bus operation. The output section has the demodulator and current-output circuitry, with provisions for external offset and span adjustment. The current-loop power supply may be completely separate from the primary supply, or it may be the same supply.

CHARACTERISTICS

The DAC1423 current-output circuitry meets or exceeds the requirements of ISA standard S50.1, Type 3, Class U. Its compliance voltage is $V_{LOOP} - 6V$, and output impedance is greater than $4M\Omega$ at dc. The d/a converter is guaranteed monotonic over the entire 0° to $70^\circ C$ operating temperature range. Temperature stability is to within $50ppm/^\circ C$ of full-scale range for both span and offset, which are initially calibrated to within ± 2 LSB ($31.2\mu A$). Both parameters have a $\pm 10\%$ maximum range of adjustment, to permit overall subsystem calibration, if desired. Power supply rejection is 20ppm of full-scale range per volt, and common-mode rejection is 103dB at mains frequency, (inputs to outputs) with 250-ohm load. Packaged in a $2" \times 4" \times 0.42"$ ($51.3 \times 102.1 \times 10.7mm^3$) module, the DAC1423 is available from stock at \$149 (1-9). ▣

0 TO 88.5dB IN 1.5dB STEPS

AD7110 Digitally Controlled CMOS Attenuator

Has Low: Noise, Distortion, Power-Consumption, and Cost

by Steve Stephenson

The AD7110* (Figure 1) is basically a 2-quadrant multiplying CMOS d/a converter. It has an internal digital decoder, which produces an antilogarithmic transfer function between the binary value of the 6-bit digital input and the analog output current. From an *audio* point of view, the AD7110 is a digitally controlled attenuator with a range of 88.5dB in steps of 1.5dB.

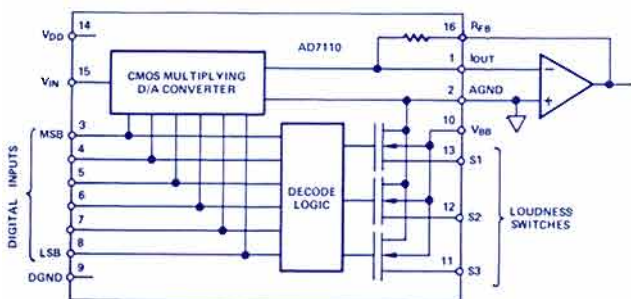

Figure 1. Functional block diagram of the AD7110 audio attenuator.

Housed in a 16-pin DIP, the AD7110 also has three CMOS switches that are activated at specific high-attenuation codes. These switches may be used for bass boost to provide a degree of compensation for the nonlinear change in frequency response of the human ear with signal level.

The AD7110's specifications anticipate its use as an audio attenuator, showing total harmonic distortion below -92dB (DIN Standard 45403) and signal-to-noise ratio of better than 100dB (10Hz to 10kHz). It is intended to replace potentiometers and analog multipliers, especially in remote and/or microprocessor-controlled applications.

Although specified as an attenuator, this CMOS DAC will find many applications in the more-established areas of signal processing, since it can handle analog signals up to $\pm 30\text{V}$, with control by the 6-bit bus over an extremely wide dynamic range. The signal frequency may be from dc to typically 150kHz , depending on the op amp that is used and the user's board layout.

The AD7110 requires a positive supply of between 5V and 12V, and—if the switches are to be utilized—a negative supply of -12V . Price (100s) is \$10.

APPLICATIONS

Figure 2a shows a circuit that provides two degrees of incremental bass-boost compensation at high attenuation levels. The response is shown in 2b.

Figure 3 shows a circuit that provides an additional bit of attenuation resolution, essentially subdividing each 1.5dB interval. When S1 is closed, R1 is paralleled with the internal feedback resistor (RFB). If $R_1 = 11R_{FB}$, the smaller total resistance results in a reduction of the output voltage by 8%. This translates into 0.75dB of attenuation.

*For technical data, use the reply card.

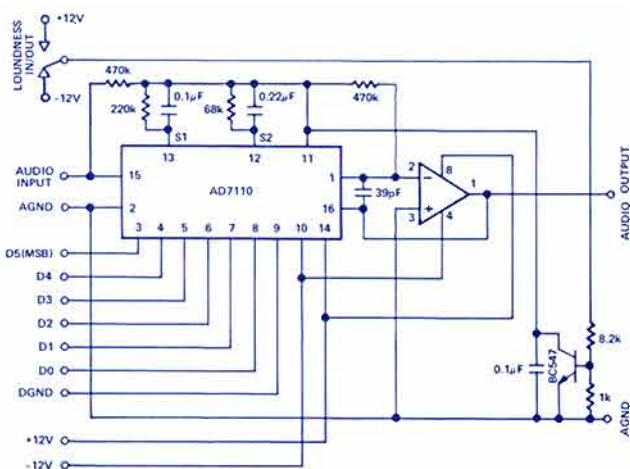

a. Single channel audio attenuator with loudness compensation.

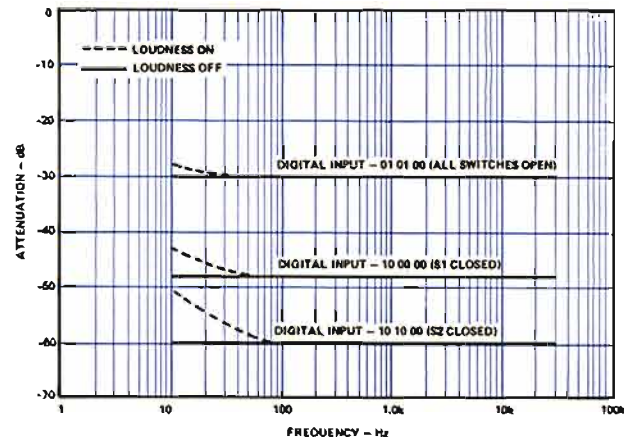

b. Attenuation vs. frequency for the circuit of a. Curves are plotted for the two digital input codes at which the loudness-compensation switches S1 and S2 are activated.

Figure 2. Loudness compensation.

For attenuations up to 48dB, the AD7110 has a guaranteed accuracy to within $\pm 0.7\text{dB}$ per step; for higher attenuations, it is guaranteed to be monotonic. In the circuit of Figure 3, the interpolated steps will be monotonic for attenuations up to 48dB, provided that R_1 is selected to $\pm 5\%$ accuracy, in terms of the actual value of R_{FB} .

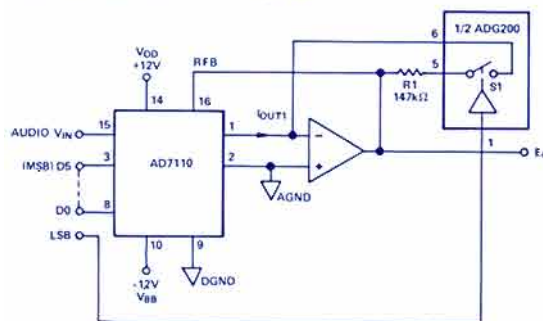

Figure 3. Single channel audio attenuator with 0.75dB resolution.

10-BIT 20MHz VIDEO A/D CONVERTER

MOD-1020 Is Complete on a 5" x 7" (127mm x 178mm) Board

Has Internal Track-Hold with $\pm 25\text{ps}$ max Aperture Uncertainty

The MOD-1020* is an ultra-high-speed a/d converter capable of digitizing video input signals to 10-bit accuracy at word rates through 20MHz. The ADC is complete with internal track-and-hold, encoder, timing circuitry, references, and latched output (Figure 1). It produces a true all-parallel digital output. The device is constructed on a single printed-circuit card, occupying only 35 square inches (0.023m²), and intended for mounting on a system mother board. Price is \$1,795 in 100s.

The MOD-1020 is ideally suited for systems requiring the highest speed-and-accuracy. Such applications include radar digitizing, digital communications (baseband digitizing), composite color-television digitizing, spectrum analysis, and medical instrumentation.

The encode-command input, digital outputs, and data-ready output are compatible with balanced emitter-coupled logic (ECL). The device requires only an external encode-command input pulse and external power supplies for operation. The analog input impedance is at least 500 Ω , which gives the user a wide range of choice of termination resistance to match that of the system. The input can be either unipolar or bipolar; offset and gain are adjustable on the card; and the device is fully repairable.

DIGITALLY CORRECTED SUBRANGING

As Figure 1 shows, the MOD-1020 has two stages of sub-ranging, with digital correction. A fast conversion produces the five most-significant bits. This portion of the output word is converted back to analog with a fast high-accuracy DAC, and subtracted from the input. The resulting residue is converted to digital (6 bits) at high speed and combined with the results of the earlier conversion to form the output word. In *digitally corrected sub-ranging* (DCS),¹ the two bytes are combined in a manner that corrects for the error of the LSB of the more-significant byte, to achieve full 10-bit resolution and accuracy.

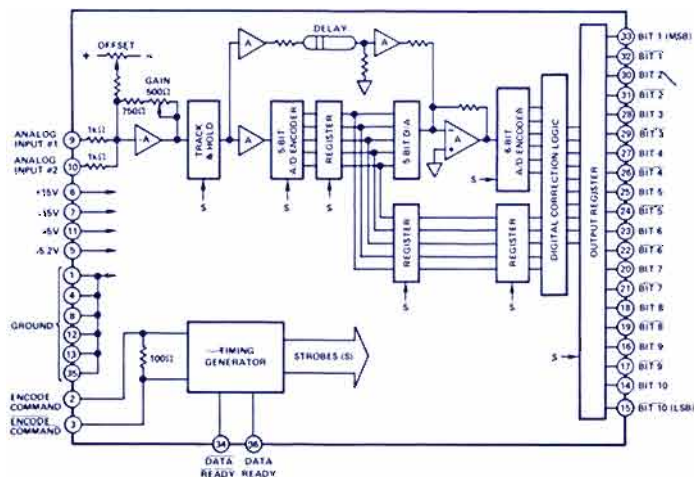

Figure 1. MOD-1020 block diagram.

*For technical data, use the reply card.

¹Described in an article by W. Pratt, scheduled for publication in ELECTRONICS, October 9, 1980.

While the complete time for one conversion is determined by the propagation delay of the input analog signal through the entire device, staged latching and carefully planned delays permit new conversions to be started (and completed) at a much faster rate. Because of pipelining, the MOD-1020 can provide 10-bit output data at a 20MHz word rate (50ns per conversion), even though the time for any one conversion, from start to finish, is two clock periods plus 185 (± 20)ns, or 285 (± 20)ns, at 20MHz (Figure 2).

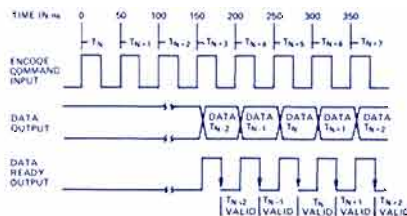
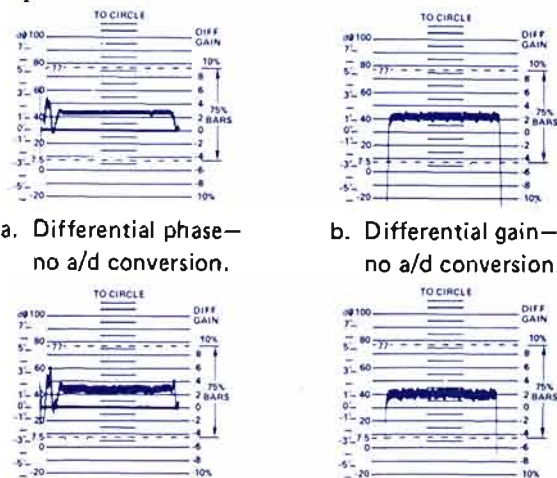

Figure 2. MOD-1020 timing diagram.

TYPICAL APPLICATION

To show the small errors associated with the use of the MOD-1020 in color-TV systems, sets of differential phase and differential gain measurements² are shown in Figure 3. In a and b, the output of a Tektronix Model 149A NTSC Test-Signal Generator, with a 20-IRE-unit TV test-signal output is displayed directly on a Tektronix Model 520A Vectorscope. In c and d, digital processing is simulated by interposing a MOD-1020 ADC and 4120E DAC; the signal is sampled at 14.4MHz, the fourth harmonic of the 3.58MHz NTSC (US) subcarrier. As can be seen, the error added by the digitizing process is consistent with the 1% differential gain and 0.5 $^\circ$ differential phase characteristics of the MOD-1020. The thickening of the scope trace is due to quantization noise in 10-bit operation. \blacktriangle



a. Differential phase—no a/d conversion. b. Differential gain—no a/d conversion. c. Differential phase—MOD-1020 ADC and 4120E DAC back-to-back. d. Differential gain—MOD-1020 and DAC back-to-back.

Figure 3. Testing differential phase and gain.

²W. A. Kester, "PCM Signal Codes for Video Applications", SMPTE Journal, November, 1979, pp. 770-778. Use reply card for reprint.

12-BIT CMOS M-DAC INTERFACES DIRECTLY WITH μ Ps

Low-Cost AD7542 Has Small Footprint (16-pin DIP)

Also Has Low Gain-Drift (5ppm/ $^{\circ}$ C max), Low Dissipation (40mW)

by John Wynne

The AD7542* is a 12-bit double-buffered multiplying d/a converter, fabricated on a CMOS chip and available in a plastic or ceramic 16-pin package. It is designed for direct interfacing with 4- or 8-bit microprocessors, and its output is made available via an external op amp.

As Figure 1 shows, the AD7542 comprises three 4-bit data registers paralleled on a 4-bit-wide bus, a 12-bit DAC register, address-decoding logic, and a 12-bit CMOS multiplying DAC. Data is loaded into the data registers in three 4-bit bytes, then transferred to the 12-bit DAC register, which updates the analog output. All data-loading or data-transfer operations are identical to the *write* cycle of a static RAM. A *clear* input allows the DAC register to be reset to all-0's when power comes up.

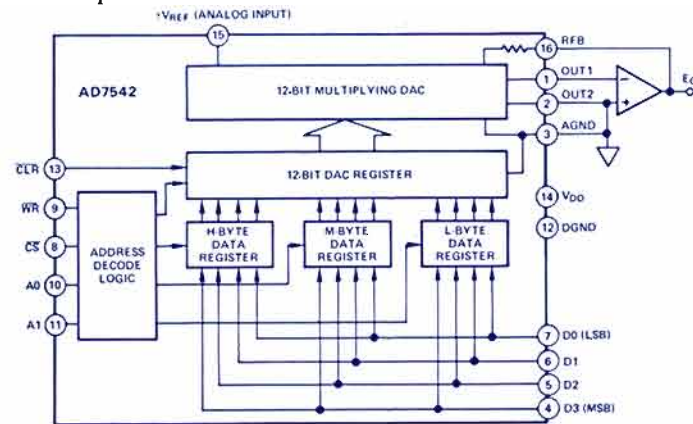

Figure 1. Block diagram of the AD7542

Its accuracy, 4-quadrant multiplying capability, low power dissipation, +5V operation, small size, and easy μ P interface make the AD7542 ideal for many applications in measurement and control†. Available in plastic, for 0° to 70° C applications, and hermetically sealed in ceramic for -25° C to $+85^{\circ}$ C applications, the AD7542 is available in two performance grades, determined by nonlinearity, $\pm 1/2$ LSB max (AD7542KN/BD), and ± 1 LSB max (AD7542JN/AD); prices start at \$9.50 (1000+, JN).

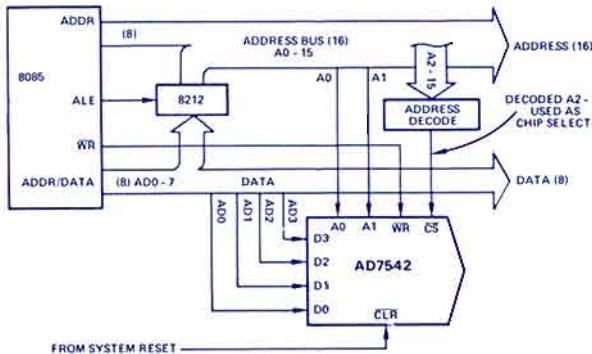

Figure 2. 8085/AD7542 interface (memory mapped output).

*For technical data, use the reply card.

†A 40-page Application Guide to the understanding and use of Analog Devices CMOS DACs is available upon request.

APPLICATIONS

Figure 2 shows how the AD7542 might be interfaced to an 8085, and Figure 3 shows a typical MC6800 hookup. Positive-going edges at \overline{CS} or \overline{WR} load the selected register, determined by $A_1 A_0$ (00 for *low* byte, 01, for *middle* byte, and 10 for *high* byte). For \overline{CS} and \overline{WR} both *low* and address 11, the DAC is updated by the contents of the data registers; otherwise it remains latched at the last value.

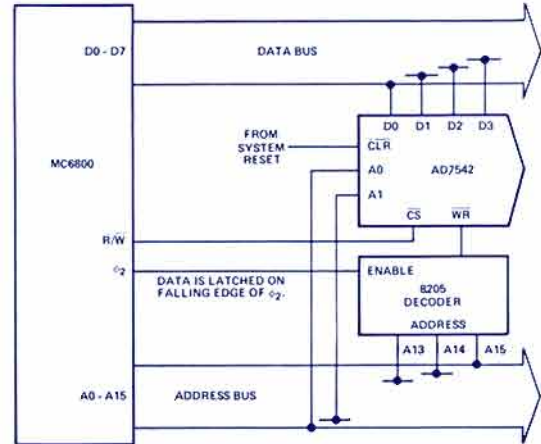

Figure 3. Interfacing the AD7542 to an MC6800 microprocessor.

Figure 4 shows a flow chart for producing a 12-bit (4095-step-max) voltage ramp under microprocessor control. First the low byte is loaded, then accumulator A is rotated by four bits and the middle byte is loaded; the high byte is loaded from accumulator B. A is compared with XX_H and B is compared with $0Y_H$ to determine if the output ramp voltage has reached its programmed level. The comparison data in the program can be changed to establish maximum output levels from 000_H to FFF_H , where 1 LSB is approximately 2.5mV. Using simple *interrupt* routines, the ramp voltage can be held at any particular level of interest; the count remaining in the A and B registers can represent comparator thresholds, external voltages, etc. ▀

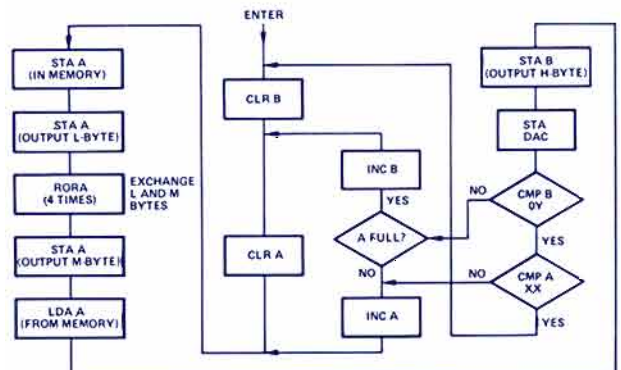

Figure 4. Flowchart for digital ramp generation.

COMPUTERIZED TEST SYSTEM FOR LINEAR DEVICES

Easy to Set Up and Use; No Programming Skills Required

Self-Generated Prompting, Operation, Display, Printout, Statistics

The LTS 2000* is a self-contained bench-top test system for such linear devices as d/a and a/d converters, amplifiers, regulators, and voltage references. It is intended to benefit users and manufacturers of devices, and independent test laboratories. It can be used in incoming inspection, device selection and grading, engineering testing, and quality control.

WHAT IT DOES

It performs a wide variety of static and dynamic tests over a wide range of device specifications, and will provide information ranging from pass/fail to binning, data logging, summarizing, and plotting of histograms. Data can be presented on its 40 character dot-matrix display (acting as a movable window on a 127-character message) or its built-in 20-character thermal printer, or interfaced to external modalities via RS232 or IEEE-488 interfaces.

All of this versatility can be commanded quite simply by users with no computer sophistication. For example, an unskilled operator needs only to load the system, insert the device, and press the START TEST switch. The LTS 2000 will do the rest, and provide any necessary further instructions to the operator, while retaining and processing the test data as required.

The tests can be defined and set up, with little special training, by a user who knows what tests (s)he wants to perform, to what specification limits, and with what form of presentation of the results. The LTS 2000 makes it easy by providing prompts and menus, i.e., by asking all the appropriate questions, which can be answered by pressing one of five function switches or using an alphanumeric keypad. In this sense, the LTS 2000 can be said to provide a *friendly* human interface.

WHAT'S IN IT

The LTS 2000's hardware interface to the device under test consists of a *family board* module (for d/a converter, op amp, etc.), a *socket assembly* and a socket p.c. board, jumpered to receive specific device types. A software-controlled handler interface is also available.

*For technical data, use the reply card.



The operating system and test programs for specific device types are permanently stored on disks, from which they are loaded into the LTS 2000.

Besides the hardware and software for analog, digital, and human interfacing, the contents of the LTS 2000 include a 16-bit TM990-101 CPU, 64K bytes of memory, source and measurement cards, and a system bus, all housed in a human-engineered 19" X 26" X 12", 65 lb cabinet. Price of the system, including an op-amp family board, is \$25,900. DAC/ADC boards are \$3000/\$4000 additional.

Software-controlled voltage sources are used to generate test levels. Automatic calibration and an internal 16-bit accurate reference permit testing 12-bit accuracy ($\pm 0.01\%$) converters; all measurements are software-corrected. In addition, device resolutions of up to 16 bits can be tested. The system calibrates itself every hour and at any time it is commanded to do so. An optional calibration interface board permits NBS-traceable calibration, with an instrument controlled via the IEEE-488 port. Testing can be stopped to permit probing of individual device pins.

TESTING IN BRIEF

Testing is controlled by the Start Test pushbutton, the five software-controlled function switches (F1-F5), and the system function keys: RESET, ESCAPE, DISPLAY, DISK, ←, →.

Startup. The appropriate Family Board and Socket Assembly are plugged in, and the LTS 2000 is turned on. The display prompts: INSERT OPERATING SYSTEM DISKETTE. That done, the oper-

ating system is automatically loaded, the machine self-calibrates and prompts: INSERT PROGRAM DISK. PRESS F5 TO LOAD. That done, the LTS 2000 identifies the program and confirms its readiness to test: DAC80CBI-V PROGRAM LOADED.

Testing. Insert the device and press the Start test switch. If the device passes all the tests, the display may indicate PASS, BIN 1, with an audible tone. Remove, place in Bin 1, insert next device. If it fails, you may see: FAIL, BIN 3, and hear the tone. Remove to Bin 3 or retest; continue until all devices in the lot are tested. Then press DISPLAY, for a choice of options (function switch labels): DLOG/SETUP/STAT/SUMSHT/DEBUG. If F4 (SUMSHT) is pressed, two options appear: PRINT/CLEAR. If F1 is pressed, the printer will produce a summary of the test data.

Creating Test Programs. The LTS 2000 helps the user create new programs. During startup, a Create program disk for the device type is inserted; F5 is pressed: DAC CREATE PROGRAM LOADED appears (for DACs). Pressing Start Test produces a prompt for a program name, which user enters from keypad; then, pressing DISPLAY: LOAD/CREATE/SAVE/DELETE/EDIT. If F2 is pressed, the machine asks about the test configuration (here are a few examples); response is via the keypad:

**NUMBER OF BITS?
POS OR NEG TRUE LOGIC (P/N)?
SERIAL OR PARALLEL DATA (S/P)?**

Then there are questions about the test options. Here are a few examples.

**TEST: UNIPOLAR ZERO (Y/N)?
TEST: FULL SCALE (Y/N)?
TEST: REFERENCE VOLTAGE (Y/N)?**

If the answer to any question is Y, a further set of prompts is given, to establish the details of the test.

The completed program may be saved, deleted, edited, or loaded.

Backed up by the component, system and test knowhow of Analog Devices, the easy-to-use LTS 2000 now fills a needed role in testing. ▣

HYBRID 12-BIT S/D CONVERTERS

Complete, Including Isolating Transformers, Laser Trimmed - No External Adjustments

The SDC1741 and SDC1742* are hybrid 12-bit-output continuously tracking synchro (or resolver) to digital converters; they employ a type 2 servo loop and interface digitally via 3-state latches. Differing only in accuracy, they provide accuracies to within ± 10 or ± 3.2 arc-min ± 1 LSB (1741/1742). Hermetically sealed in the 32-pin metal dual in-line package, they are available fully screened to MIL-STD-883, Class B, for \$595 (SDC1742 883 option in 100s).

The internal transformers and low profile (0.26") make these devices unusually suitable for applications where space and weight are at a premium, and external transformers cannot be tolerated.

The three-state 2-byte separately enabled outputs permit direct multiplexing on 8-bit microprocessor buses. An INHIBIT command, which freezes the outputs for data transfer, does not interfere with the

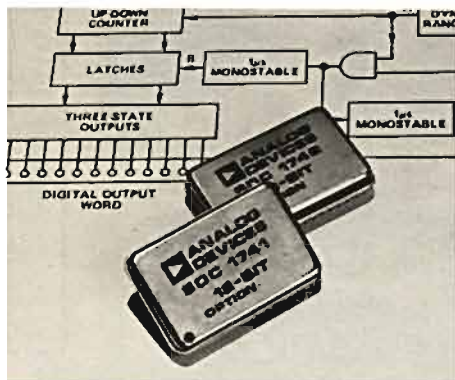

tracking process, which continues to produce correct data.

Nominal reference frequencies are 400Hz and 2.6kHz. The 400Hz models provide full accuracy from 360Hz to 1kHz; the 2.6kHz models are fully accurate from 2 to 3kHz. The tracking rate is 18rps. Signal and reference inputs are resistively programmable. All options operate over the full -55°C to $+125^{\circ}\text{C}$ range. \square

FAST A/D CONVERTER MODULES

8/10-Bit Conversions in 0.75/1 μ s max

MAH-0801/1001 Have Parallel and Serial Outputs

Models MAH-0801 and MAH-1001* are high-speed, high-linearity a/d converters, with max conversion times of 750ns and 1 μ s to 8 and 10 bits. Typical applications include high-speed data acquisition, real-time waveform analysis, radar signal processing, and analytical instrumentation.

Employing successive approximations, these device have no missing codes over the entire 0° to 70° temperature range. While their speed, accuracy, and low cost may make these 2"x4"x0.4" modules a first choice for many new applications, they have the added benefit of being physically compatible with existing designs from other manufacturers, for example the 4130 and 4131, but with twice the linearity. Prices are \$195/\$219, 1-4.

The MAH-0801/1001 are optionally available with unipolar (0 to -5V or 0 to -10V)

*Use the reply card for technical data.

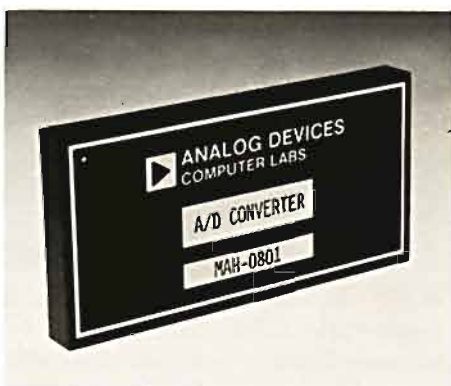

or bipolar ($\pm 5\text{V}$, $\pm 10\text{V}$, $\pm 1.024\text{V}$) inputs, and output coding is available in binary, offset binary, and twos complement.

In addition to parallel outputs, a serial output (non-return-to-zero) is provided. For high-speed applications the THS-0060 track-hold is recommended for 8-bit applications, and the THC-0300 for 10-bit conversion. \square

4 1/2-5 1/2-DIGIT ADC Subsystem On a Chip

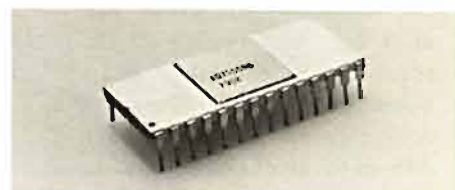

The AD7555* is a CMOS integrating a/d conversion subsystem. It contains, on a single chip in a 28-pin plastic or hermetically sealed ceramic package, all the control and interface logic, counters and CMOS analog switches required for 4 1/2-digit (expandable to 5 1/2) conversion, using the patented quad-slope technique. When connected to a buffer op amp, analog integrator, and comparator, of medium precision, it is capable of achieving scale factor drifts of the order of $0.2\text{ppm}/^{\circ}\text{C}$, and accuracy to 1 count in 20,000.

The output is available both in multiplexed BCD—for displays, including polarity and overrange—and as a serial count, which can be used for microprocessor interfacing, data reformatting (up to 200k binary counts), or—with a rate multiplier—for linearization.

The quad-slope conversion algorithm converts the external amplifier's input drift errors to a digital number, which is used to cancel drift digitally, reducing drift errors to a second-order effect. A ratio-metric device, the AD7555 requires a single positive reference to handle bipolar input signals.

Pricing starts at \$19.75 (KN in 100s). \square

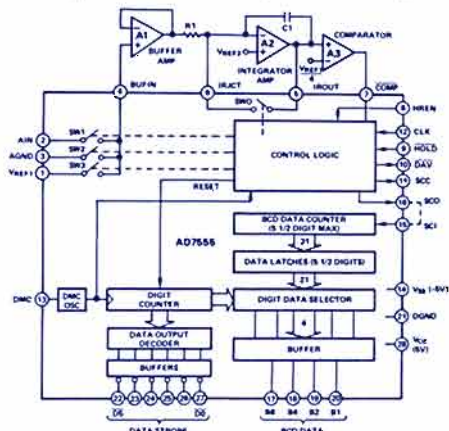

*For technical data, use the reply card.

DATA-ACQUISITION FRONT END

AD362 Has Sample-Hold, Multiplexer, Logic, Permits Free Choice of A/D Converter

The AD362* is the analog input section of a complete 16-channel 12-bit data-acquisition system; it is packaged in a hermetically sealed 32-pin metal DIP. Accepting up to 16 single-ended or 8 differential analog inputs, or combinations selected by a logic-switched mode control, it provides the multiplexing, differential amplification, and sample-hold functions.

Its salient characteristics include linearity to better than $\pm 0.005\%$, $10\mu\text{s}$ acquisition time to 0.01%, high differential input impedance, and 70dB common-mode rejection (min at 1kHz, 20V p-p). Complete and calibrated, it has gain and offset tempcos of $\pm 4/2\text{ppm}/^\circ\text{C}$ max and $\pm 2/1.5\text{ppm}/^\circ\text{C}$ max (AD362KD: 0° to 70°C / AD362SD: -55°C to $+125^\circ\text{C}$). Price is \$119.50/\$230 (KD/SD, 100s).

The AD362, when used with a user-selected a/d converter, forms a complete, accurate high-speed data-acquisition system. Typical Analog Devices converters used with the AD362 include the AD574*

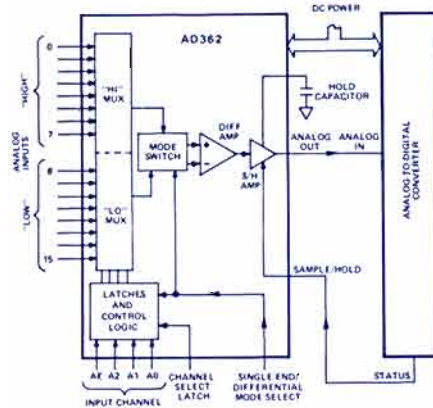

12-bit IC, the AD572 12-bit hybrid, the popular 12-bit AD ADC80*, the 10-bit AD571*, the high-rel 12-bit AD5200*, the high-speed AD578 and the ultrafast hybrid 8-10-12-bit HAS series*.

A low-dielectric-absorption HOLD capacitor (to be connected externally), furnished with the unit (polystyrene: KD/teflon: SD), supports 12-bit accuracy. \blacksquare

*Use the reply card for technical data.

FAST HYBRID A/D CONVERTER

AD578: Complete 12-Bit Conversion in $3\mu\text{s}$ Low Power, Low Cost, No External Parts

The AD578* is a complete 12-bit a/d converter in a 32-pin dual in-line package. Its short conversion time ($3/4.5/6\mu\text{s}$: L/K/J) makes the AD578 an excellent choice in a variety of applications where system throughput rates from 166kHz to 330kHz are required. In addition, it may be short-cycled to obtain faster conversion speeds at lower resolutions.

Important performance characteristics of the AD578 include maximum linearity error of $\pm 0.012\%$ at $+25^\circ\text{C}$, maximum gain tempco of $\pm 30\text{ppm}/^\circ\text{C}$ (including internal reference), and typical power dissipation of 775mW. The J and K versions are packaged in a ceramic DIP. Prices in 100s: J: \$85, K: \$99.50, L: \$124.50.

The AD578 has both parallel and serial positive-true outputs. For unipolar inputs (0 to +10V, 0 to +20V, pin-program-

*For technical data, use the reply card.

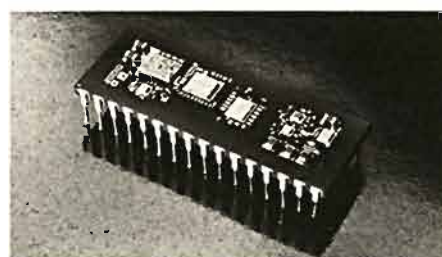

mable) the coding is binary; for bipolar inputs ($\pm 5\text{V}$, $\pm 10\text{V}$) the choice of parallel codes is twos complement or offset binary. \blacksquare

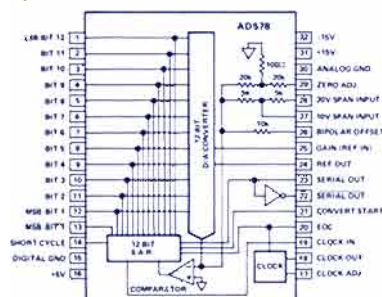

12-BIT DAC FAMILY

AD370/371 Complete, V-Out Low-Power Hybrids

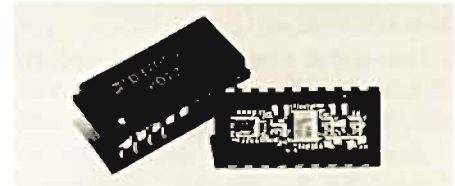

Models AD370 and AD371* are complete, 12-bit low-power voltage-output d/a converters, which differ only in output range; the unipolar AD371 has a 0 to +10V swing, and the bipolar AD370 swings $\pm 10\text{V}$ — coding is complementary binary and complementary offset binary, respectively.

Both devices contain monolithic CMOS DACs, precision high-speed FET-input op amps, and low drift references, and are furnished in 18-pin packages, with a choice of hermetic or lower-cost polymer sealing. Because only four, internally trimmed, chips are used, the AD370/371 tend to be more reliable and less costly than other devices with compatible pinouts currently available on the market (e.g., the DAC346/347/356 and MN360/362/370/371/3210/3211 families).

Dissipating only 150mW max, the AD370 and AD371 operate from $\pm 15\text{V}$ supplies and have guaranteed max full-scale settling time of $35\mu\text{s}$ to $1/2\text{LSB}$. A choice of accuracy grades is available, J/K for 0° to $+70^\circ\text{C}$ operation, and S for the -55°C to $+125^\circ\text{C}$ MIL range.† Max nonlinearity over the temperature range is $1/1/1/2\text{LSB}$ for J/K/S; and internally trimmed calibration error is 0.05% max at 25°C and 0.2/0.2/0.3% max over the temperature range. Prices for either type in 100s are \$34.50/ \$39.50 for JN/KN with polymer seal, and \$42/\$47.50/\$57.50 for hermetically sealed JD/KD/SD. \blacksquare

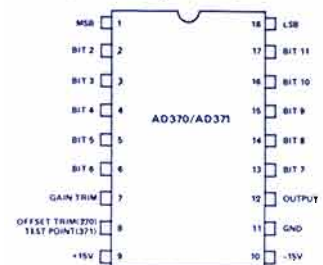

*For technical data, use the reply card. †S grade units are also available with 100% screening to MIL-STD-883B, Class B.

MACSYM: THREE NEW INPUT CARDS

AIM04, FIN01/02, AIM05 Provide Direct Interfacing to: 16 Isolated Channels, 8/16 Frequency-Inputs, 4 Bridge-Type Sensors

MACSYM* computer-based Measurement And Control SYStems have been described in these pages in recent issues (MACSYM 2 in 13-1 and MACSYM 20 in 14-1)*. An important aspect of MACSYM is the availability of a growing family of completely compatible analog/digital input/output (ADIO) cards for direct interfacing of transducers, output devices, and control signals, under software control in BASIC (MACSYM 2) or a powerful command set (MACSYM 20).

The new cards described here extend the reach of MACSYM to three kinds of real-world signal sources:

• *Model AIM04** is a 16-channel flying-capacitor multiplexer. It provides MACSYM users with a means of interfacing low-level analog inputs in a high-common-mode environment (up to 250V ac max). The card accepts 16 differential inputs, multiplexes them through a software-programmable-gain amplifier (X1, X16, X256), and presents the selected input to MACSYM's ADIO bus, and ultimately to the system a/d converter.

• *Models FIN01/02** are 8- and 16-channel frequency-input boards capable of accurately measuring the signal frequency at a selected input, in the range from 1.6Hz to 500kHz. These cards are useful in dealing with flowmeters, tachometers, and voltage-to-frequency transmitters. The actual measurement performed is *period*, which is converted to frequency data by the software driver used to access and read data from the card.

• *Model AIM05** is a 4-channel strain-gage interface board, which provides MACSYM users with a means of direct interface to most common bridge-type transducers. Each input channel independently provides excitation, bridge completion, amplification, and filtering. 120Ω or 350Ω bridges can be directly interfaced, in one-, two-, or four-arm configurations.

*Technical data on these products and MACSYM systems, and copies of DIALOGUES 13-1 and/ or 14-1 are available upon request. Use the reply card.

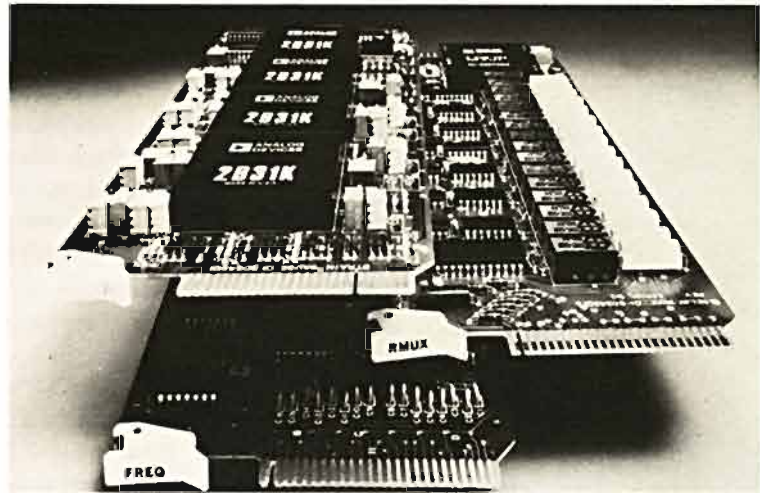

AIM04 16-CHANNEL ISOLATED MULTIPLEXER

The Thermosen relays used for isolation and sampling were chosen for their low thermal EMF and fast switching (130 samples per second). Nonlinearity is less than 0.01% of full scale range, and gain accuracy is to within 0.02%. The PGA gains on the card, combined with the gains available in the MACSYM ADIO controllers, allow twelve system gain settings from 1 to 2048V/V, in binary increments.

The card contains all of the timing logic needed for accurate analog measurement. Gain selection, relay switching, and conversion of the input signal by the system a/d converter are all controlled by on-board circuitry. This significantly simplifies the user's software burden, eliminating the need for a user-programmed time-out loop for relay debounce, and insuring that the capacitor is read during the short window in which valid voltage readings are present.

The inputs are fully protected against differential input overvoltage up to $\pm 100V$; common-mode rejection is 110dB at $G = 256V/V$, and drift is less than $30ppm/^{\circ}C$.

FIN01/02 FREQUENCY-INPUT BOARDS

Both cards share the same basic design, differing principally in the number of channels handled (8/16). The period of the selected input is measured by counting

pulses from an accurate high-frequency clock during an integral number of input cycles.

A Schmitt trigger with adjustable sensitivity and hysteresis permits most common waveforms to be handled: TTL inputs, low-level periodic analog signals, and high- and low-level signals symmetric about zero. Combined with a software-controlled prescaler and time-base synthesizer, it allows users to measure a wide range of frequencies with excellent (up to 0.0015%) resolution. Software-controlled self-test is available without disturbing the inputs.

AIM05 STRAIN-GAGE INTERFACE BOARD

Used for such measurements as pressure, acceleration, weight, and stress, each channel uses a 2B31* signal conditioner, which includes excitation, preamplification, and filtering. Excitation is switch-selectable at +5V or +10V; Gain is adjustable from 1 to 1024V/V in 8 steps; and the filter cutoff frequency, normally set at 2Hz, can be increased by the user (by adding 3 resistors). The user may also use shunt calibration, controlled by an on-board software-controlled relay (solder currents are provided to receive the matched calibration resistors supplied by the gage manufacturer).

Prices for the boards are (1-5): AIM04, \$800; FIN01/02, \$450/\$600; AIM05, \$700. ▣

LOWEST-COST ISOLATION AMPLIFIERS

Model 290A Self-Contained, Single-Channel

Model 292A Synchronizable, Multi-Channel



Models 290A and 292A* are low-cost compact isolation amplifiers optimized for single- and multi-channel industrial transducer applications. In data-acquisition systems, computer-interface systems, process-signal isolators, and high-CMV instrumentation, these 1.5"X1.5"X0.62" (38X38X15.7mm³) modules offer complete galvanic isolation and protection against damage from transients and fault voltages up to 1500V dc continuously applied, at a price of only \$30 (100's).

Characteristics of these devices include: adjustable gain, from 1 to 100V/V, dual isolated power ($\pm 13V$ dc) for external front-end auxiliary circuitry, CMR of 100dB min at 60Hz (1k Ω source imbalance), noise of 1 μV , peak-to-peak (10Hz bandwidth, G = 100V/V), non-linearity of $\pm 0.1\%$ at 10V peak-to-peak output, and an input/output dynamic range of 20V peak-to-peak.

The isolated power provides the capability to excite floating signal conditioners, front-end buffer amplifiers, and remote transducers, such as thermistors or bridges. The adjustable gain permits either high-

*For technical data, use the reply card.

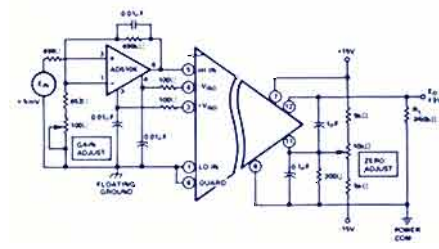

Input signal conditioning using isolated power for transducer buffer amplifier.

or low-level signal inputs to be handled.

A single synchronizing oscillator can drive as many as 16 292As, and many more can be driven with additional oscillators. The user can supply the oscillator circuit or specify the Model 281 modular oscillator, which includes a regulator for operation over the supply range +8V to +28V.

Using modulation techniques with reliable transformer isolation, these conservatively designed devices, capable of operation in harsh environments ($-25^{\circ}C$ to $+85^{\circ}C$ operating temperature), have a calculated MTBF of more than 400,000 hours and are designed to meet the requirements of MIL-STD-202E environmental testing as well as the IEEE Standard for Transient Voltage Protection (472-1974: Surge Withstand Capability). \square

VERSATILE ADC 8-Bit AD7574 Interfaces To μP s Like Memory

The AD7574*, a low-cost μP -compatible CMOS a/d converter in an 18-pin DIP, performs an 8-bit conversion in 15 μs . A completely self-contained ratiometric converter, it includes comparator, clock, d/a converter, successive-approximation register, and interface & control logic. Requiring but a single +5V supply, (at 30mW), it operates over the specified temperature range without missed codes.

Designed to be operated as a memory-mapped-input device, the AD7574 can be interfaced like static RAM, ROM, or slow memory. Its \overline{CS} (decoded device address) and \overline{RD} (\overline{READ} /WRITE control) inputs are available in all μP memory systems. They control all ADC operations, such as starting conversions or reading data. Three-state output allows operation on a bus or system input port.

Available for 0° to $70^{\circ}C$ or $-55^{\circ}C$ to $+125^{\circ}C$ temperature ranges, its prices start at \$7.50 in 100s. \square

*Use the reply card for technical data.

HYBRID DATA AMPS

Binary Gain, 1 to 1024

Pin-Programmable

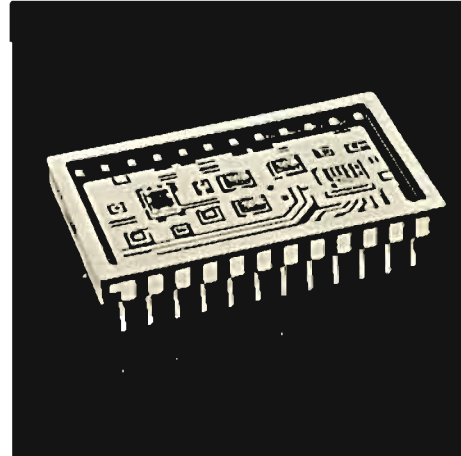

Models AD612 and AD614 are high-performance instrumentation amplifiers in the 24-pin dual in-line package. Gain is accurately set to one of eleven binary values by simple jumper connections. Once set, its accuracy is better than $\pm 0.02\%$ without external trimming (AD612C), and its maximum tempco (-25° to $+85^{\circ}C$) is only ± 10 ppm/ $^{\circ}C$. Offset voltage, initially set to within ± 0.2 mV (adjustable to zero) has a maximum tempco of $\pm 1.0\mu V/^{\circ}C$ referred to the input and $75\mu V/^{\circ}C$ at the output.

Designed for speed as well as accuracy, the AD614A/B have a small-signal bandwidth of 160kHz and maximum settling time of 30 μs to 0.01% at G = 128. The common-mode rejection of both types is 94dB min, at a gain of 1,024, and 74dB min at unity gain.

Typical applications for this family include multichannel programmable-gain data-acquisition systems, programmable-gain instrumentation amplifiers, preamplifiers for recorder instrumentation, and transducer interfacing in general. Price of the AD612 starts at \$40. (A in 100s).

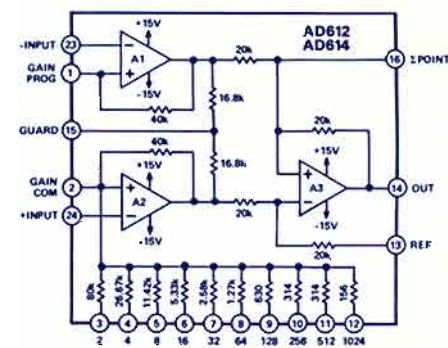

DAC CONTROLS PRECISION UHF NOISE LEVEL Flat ($\pm 0.1\text{dB}$) from 1 to 500MHz, Stable to $1:10^4$ Noise Generator Proves that Vacuum Tubes Aren't Dead

by W. A. Coles and H. J. A. Chivers*

The vacuum tube is making one of its last stands in the form of a high-precision noise generator for frequencies up to UHF. While solid-state noise generators are smaller, lighter, more robust, and less thirsty for power, the thermionic diode is an absolute standard. Solid-state generators produce avalanche-amplified shot noise; therefore, they are sensitive to the avalanche gain, which must be calibrated and stabilized. The thermionic diode, on the other hand, produces shot noise directly, thus the noise-current spectral density, $N_i = 2eI_p A^2/\text{Hz}$, depends only on the mean plate current, I_p , which is easily stabilized. The spectral density is white up to frequencies of the order of the inverse of the transit time (UHF).

The plate current depends on the number of electrons boiled off the cathode (by heating of the filament). Thus, the control problem is to adjust the heater power so as to provide the desired plate current. Some earlier instruments, in which the plate current was read on an ammeter suitably scaled to read noise temperature, are hard to maintain, awkward to control digitally, prone to drift—and no longer manufactured.

With the objectives of achieving stability of $1:10^4$ and at least 1000 discrete steps of noise-temperature adjustment, La Jolla Sciences recently designed an instrument with an improved control system for radio-astronomers and others working with low-noise systems at frequencies up to UHF. Modern ICs were used to minimize maintenance.

Figure 1 shows the basic control loop. The noise temperature of a diode is proportional to the plate current, I_p , which is measured and compared with the reference signal, I_{IN} . The error is processed by a loop filter (basically an integrator), which seeks to keep its steady-state input at zero in the closed loop, by modulating the filament power to increase or decrease the filament temperature (hence the plate current—and the noise) as required to maintain the desired value of I_p .

Figure 2 shows the system implementation. The reference signal is established by a d/a converter. For manual control, a BCD device (AD DAC80 CCD-V#), driven by rotary switches, is used; the binary version is used where automatic digital control is called for. The 40mA plate current is scaled down to typical op-amp current levels at low impedance; this calls for a low-drift amplifier (AD301AL#) because of the attenuation and the required $1:10^4$ stability. A low-bias-current

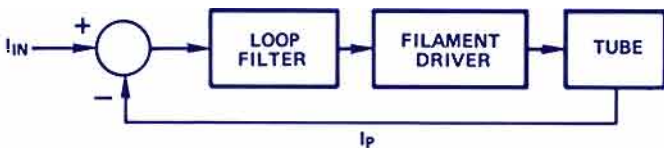

Figure 1. Basic control loop of the noise generator. In steady state, $I_p = I_{IN}$.



device (AD308A#) is used as the integrating amplifier†; the summation and integration are separated in order to maintain reasonable capacitance values. A $\mu\text{A}78\text{H}05$ voltage regulator is used as the power amplifier, as a simple compromise, for clean filament drive (the loop bandwidth is not broad enough to cope with the harmonics of 60Hz, to avoid the need for a nonlinear filter to correct for nonlinearity of the tube characteristic).

The noise output from production instruments is flat ($\pm 0.1\text{dB}$) from 1 to 500MHz. The output is adjustable in steps of either 1 or 10 kelvins, from 0 to 1299K or 0 to 12990K. Stability is better than $\pm 0.001\text{dB}$; output impedance is 50Ω ($\pm 0.1\text{dB}$). The instrument may be controlled by the switches on its panel or a remote set of switches, or by a computer (using a binary DAC). ▀

*Messrs. Coles and Chivers are with La Jolla Sciences, 301 South Granados Avenue, Solana Beach, California 92075 (Tel. 714-755-4556).

#Use the reply card for data on Analog Devices products.

†Ed. note: The FET-input AD542 is also a good choice.

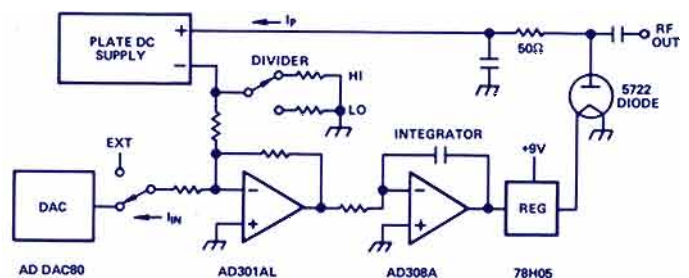

Figure 2. Functional schematic of the noise generator.

PUTTING THE AD558 DACPORT™ ON THE BUS

Interfacing to Microprocessors with One Easy Chip

The Complete, 5V-Powered, Bits-In-Volts-Out Buffered AD558

by Doug Grant

The AD558, announced in the last issue (14-1)*, represents a major breakthrough in monolithic DAC technology. It is a complete true 8-bit d/a converter in a 16-pin DIP—including a stable 2.5V band-gap reference, output amplifier, and a data latch—designed to operate from a single positive power supply, like many of the μ Ps it is designed to work with (Figure 1).

The actual digital-to-analog conversion is accomplished by means of eight PNP current switches, which drive a precision thin-film R-2R ladder network to produce a direct unbuffered 0 to 400mV analog signal. The high-speed output amplifier has two pin-programmable output ranges, 0 to 2.56V and 0 to 10.0V. Settling time of the positive-going voltage output is typically 700ns for a full-scale step, and single-supply operation is achieved with a resistive-pulldown output stage following a proprietary non-saturating driver.

DIGITAL INTERFACE

The PNP current switches are driven from the outputs of an octal level-triggered data latch, fabricated by the use of linear-compatible I²L (Integrated Injection Logic) technology. This proven Analog Devices process provides a dense low-power logic family which can be produced along with the linear components necessary for 8-, 10-, and 12-bit converter design.

The latch is operated from two TTL-compatible control signals, \overline{CS} (Chip Select) and \overline{CE} (Chip Enable). The truth table for the latch is shown above. The \overline{CS} and \overline{CE} inputs are fully interchangeable, and the latch is transparent when both are low. When either control input goes HIGH, the eight-bit data word is latched and the analog output is unaffected by further activity on the data lines. This latch permits the device to be interfaced simply to many popular microprocessors, as the illustrations on the opposite page show.

Input Data	\overline{CE}	\overline{CS}	DAC Data	Latch Condition
0	0	0	0	"transparent"
1	0	0	1	"transparent"
0	1	0	0	latching
1	1	0	1	latching
0	0	1	0	latching
1	0	1	1	latching
X	1	X	previous data	latched
X	X	1	previous data	latched

Notes: X = Does not matter
 1 = Logic Threshold at Positive-Going Transition

INTERFACING TO MICROPROCESSORS

While microprocessor control signals vary widely from one architecture to the next, there are two conditions that must be met in order to update the AD558. First, the processor must indicate which memory (or I/O) location is being occupied by an AD558. An address decoder is used to provide a unique signal for each distinct address. This signal is normally applied to \overline{CS} (Chip Select). Depending on system complexity, this decoding may range from direct connection to an address line to a complete decoding of all memory locations. Second, the processor must indicate whether the data on the bus is flowing from processor to memory (WRITE) or from memory to processor (READ). In the case of a DAC, a WRITE signal is used (a DAC may be thought of as write-only memory). This signal is normally applied to the DACPORT's \overline{CE} (Chip Enable). Many microprocessors (e.g., 8080A, 8085A, 8048, Z80, 1802) provide two possible methods of sending data to an AD558 or other input/output port: *memory-mapped* and *isolated* I/O. Both types are useful. In memory-mapped I/O, the input/output devices are treated as part of the memory. This allows the full range of memory-reference instructions and addressing modes to be used to manipulate the data. The 6800- and 6502- series processors use memory-mapped I/O exclusively, as do most minicomputers.

The isolated I/O approach, available on 8080-type machines, treats the I/O devices as separate system elements, accessed by READ and WRITE signals. In the 8080A, while there are 64K memory locations, there are only 256 dedicated I/O addresses. This permits simpler address decoding in some systems. The primary disadvantage of isolated I/O is that all data must pass through the accumulator. Direct program-controlled transfer of data from any other register (or a memory location) to an I/O device is not possible.

The actual hardware connection is dictated by system architecture and timing. The figures on page 17 show how some of the variations in architecture apply to interfacing the DACPORT. More-detailed information on hardware, software, and timing aspects of interfacing the AD558 to μ Ps can be found in the Application Note from which this article is drawn: "Interfacing the AD558 DACPORT™ to Microprocessors."*

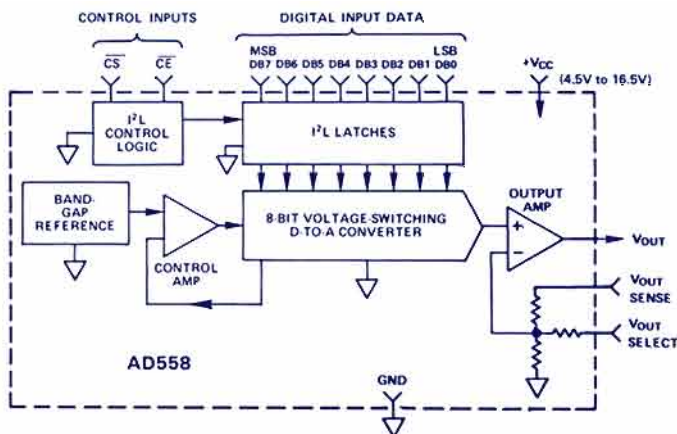
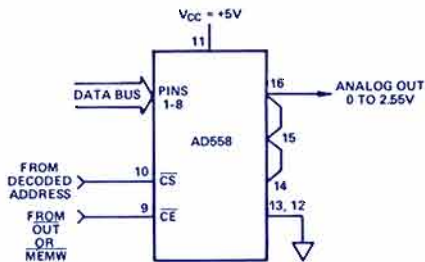

Figure 1. AD558 Functional Block Diagram.

*Use the reply card for technical data on the AD558, and/or for a copy of a more-detailed 8-page Application Note, on which this Brief is based.



TYPICAL CONNECTIONS FOR A GENERAL INTERFACE TO THE AD558'S CS AND CE INPUTS

Control signal connections to AD558.

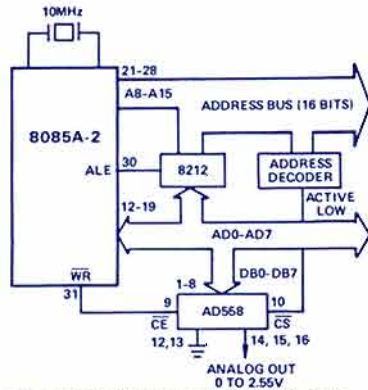

THE SPEED OF THE INTERNAL LATCH ALLOWS THE DACPORT TO KEEP UP, EVEN WITH AN 8085A RUNNING WITH A 10MHz CRYSTAL (5MHz CLOCK)

AD558-8085A interface.

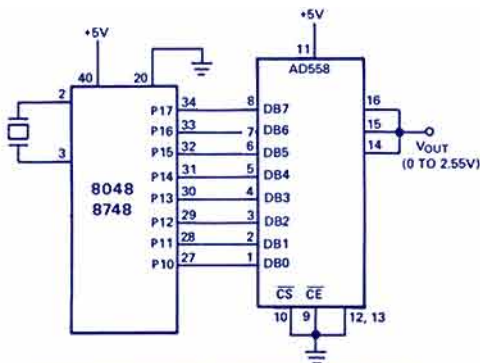

THE LEVEL SENSITIVE LATCH CAN BE HARDWIRED INTO A TRANSPARENT MODE, ALLOWING THE AD558 TO BE USED ON LATCHED I/O PORTS, SUCH AS THOSE PRESENT ON THE 8048 SINGLE-CHIP μ C

AD558 connected to dedicated I/O port of 8048 micro-computer.

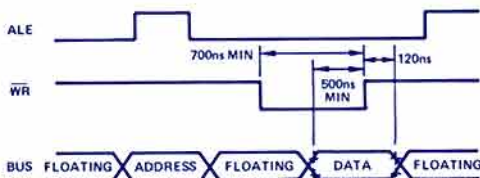

IN EXPANDED 8048 SYSTEMS, THERE IS AN INTERVAL DURING WRITES TO EXTERNAL MEMORY WHEN WR IS VALID BUT DATA IS NOT YET STABLE; HOWEVER, DATA IS STABLE FOR OVER 100ns AFTER THE RISING EDGE OF WR, SUCH THAT A 100ns ONE-SHOT CAN PROVIDE A VALID CE FOR THE DACPORT.

8048 timing for external memory write.

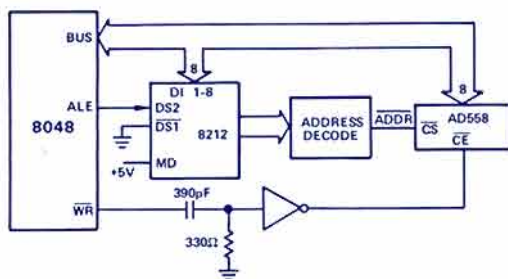

AD558 as external data memory in expanded 8048 system.

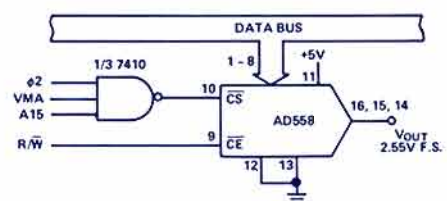

THE 6800/6502 TIMING SPECS ALSO DEFINE A 200ns INTERVAL WHEN DATA IS NOT STABLE, WHICH CAUSES A MOMENTARY GLITCH AT THE OUTPUT. THIS CIRCUIT WORKS IF THE SYSTEM IS IMMUNE TO SUCH SHORT-LIVED ANOMALIES

Simple 6800 interface.

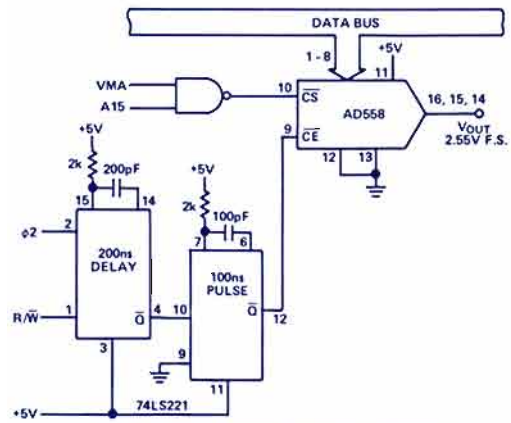

IF GLITCHES DUE TO DATA TIMING MUST BE AVOIDED, A DUAL ONE-SHOT CAN PROVIDE A SUITABLE DELAYED STROBE PULSE FOR THE DACPORT.

Glitch-free 6800 interface.

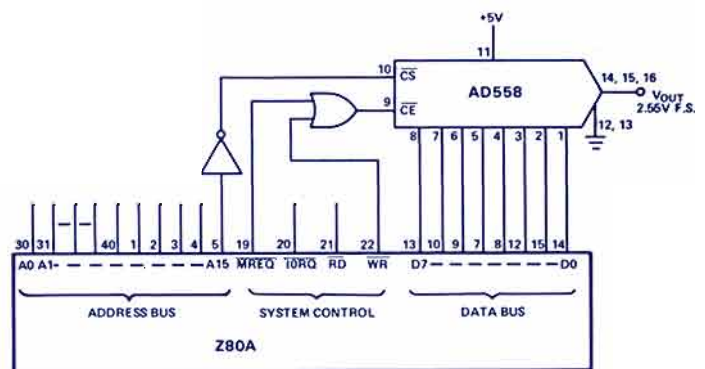

THE Z80A TIMING IS IDEAL FOR THE DACPORT. WR IS VALID ONLY WHEN DATA IS VALID AND STABLE, AVOIDING GLITCHES.

Z80A-AD558 interface.

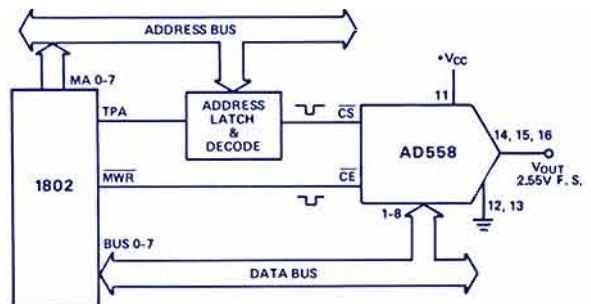

THE 1802 CMOS PROCESSOR ALSO PROVIDES A MWR ONLY WHEN OUTPUT DATA IS VALID. THE POWER SUPPLY RANGE OF THE AD558 (4.5V TO 16.5V) ALLOWS THE SAME POWER SUPPLY TO BE USED FOR BOTH THE DAC AND THE CMOS LOGIC IN THE SYSTEM.

1802-DACPORT connection.

SHORT-FORM GUIDE

The *1980 Short-Form Guide to Electronic Products for Measurement and Control* is now available from Analog Devices upon request. A comprehensive digest of our entire product line, its 48 pages include specifications and brief descriptions of devices ranging from converters and op amps to MACSYM Measurement And Control SYStems. If you have not yet received a copy, or would like an extra one, use the reply card to request it.



MACSYM 2

The *Macsym 2 System Digest* is a 20-page brochure that describes MACSYM 2's hardware, software, and applications, and provides a summary of the MACBASIC language. Included are descriptions, examples, specifications, photographs, and drawings. The Digest is available upon request; use the reply card.



NEW HANDBOOK

The *Transducer Interfacing Handbook: A guide to analog signal conditioning*, edited by D. H. Sheingold, published in hard-cover by Analog Devices, 1980. 266 pages, \$14.50. ISBN: 0-916550-05-2.

This book shows the circuit and system designer how to understand and connect to transducers, for sensing temperature, pressure, force, level, and flow; and it shows the transducer user how to apply them in electronic circuits for measurement and control. A practical book for the working engineer, scientist, and technician, its principles are illustrated by nearly one hundred applications.



CONTENTS

1. The transducer as a circuit element
2. Interfacing considerations — bridges
3. Interfacing considerations — interference
4. Amplifiers and signal translation
5. Offsetting and Linearizing
6. Overall considerations; two interface-design examples
7. Applications: Thermoswitches and thermocouples
8. Resistance Temperature Detectors (RTDs)
9. Thermistor interfacing
10. Semiconductor temperature transducers
11. Pressure-transducer interfacing
12. Force-transducer interfacing
13. Flowmeter interfacing
14. Interfacing level transducers
15. Application miscellany

Appendix — Bibliography — Device Index — General Index

Order your copy from P.O. Box 796, Norwood MA 02062. Use enclosed card, or send check or Master-Charge information.

HIGH-RESOLUTION ΔT MEASUREMENT

An article on the above subject appeared in *Dialogue* 13-2, discussing ways of using AD590 current-output temperature sensors in differential temperature measurements.

One reader on the West Coast wondered where to get a 10 μ A full-scale 8" analog meter. Frank Goodenough responds, "Triplett Mfg. Co., Bluffton, Ohio 45817, provides 8" 10 μ A-full-scale meters (taut-band suspension) in their 820-GL and 820M series. They can be modified by distributors, such as E.I.L., for zero-center operation, if need be."

Another reader had difficulty observing the high resolution of which AD590 differential-temperature circuits are capable. While it's hard to trouble-shoot at a distance, a few comments are in order in pursuit of the elusive millidegree.

- Naturally, the test setup should be free from gradients due to ambient temperature variation, through such agencies as Dewar flasks, metal boxes, foam insulation, isothermal mounting.
- Operate the AD590s at the lowest voltage consistent with good performance, to minimize internal heating and gradients.
- Sensitive leads, and in fact, the entire front-end electronics package, should also be sheltered from ambient temperature gradients and electromagnetic interference, in an adjacent separate box within the instrument housing.
- The electronics should be checked with an oscilloscope to make sure that there are no low-level oscillations, which can look like sources of low-frequency noise and drift to a blind meter. Noise at frequencies high compared to the signal should be filtered out to avoid dc errors due to intermodulation.

ERRORS IN SAMPLE-HOLDS

We have been taken to task by a reader who feels that we oversimplify when we (and others in the industry) assert that the crucial specification affecting timing error in a data-acquisition system involving a sample-hold is aperture uncertainty (the uncertainty—due to jitter—of knowing the exact time of opening of the sampling switch—*after any fixed aperture delays or advances have been accounted for*).

He calls attention to the phase lag in the tracking mode, points out that it, too, is a timing error, and that in a system involving two or more sampled channels (where relative timing is critical), the difference in tracking phase lags between any two devices may introduce an error that can be several binary orders of magnitude greater than the aperture error.

He cites an example of a 14-bit track-hold with 0.5ns aperture uncertainty. The maximum frequency that can be sampled with less than 1/2LSB error due to aperture uncertainty is $2^{-(n+1)}/\pi\tau_{au}$, or 19.4kHz. However, its small-signal -3dB response is 1MHz, which implies a time constant of 160ns (for a unit-lag response), 320 times the aperture uncertainty. If two devices have time constants differing by 10%, that timing difference will be 32 times (or 2⁵) as great as the timing error caused by τ_{au} . Thus the maximum frequency that can be sampled with less than 1/2LSB error due to *unadjusted* differential tracking phase lag is about 600Hz.

There is certainly merit to his argument, and we appreciate his reminding us of it. In turn, we should note that the devices have typical aperture delay time of 50ns, 100 times as great as the aperture uncertainty. This fixed component is minimized by phasing the times at which the 2 devices are gated into HOLD. Similarly, it is not unfeasible to adjust the phases of the *analog* signals in such a way as to minimize error.

An Eclectic Collection of Miscellaneous Items of Timely and Topical Interest. Further Information on Products Mentioned Here May Be Obtained Via the Reply Card.

IN THE LAST ISSUE (Volume 14, No. 1, 1980) . . . MACSYM 20: Low-Cost Measurement And Control SYstem . . . The New Generation of Isolation Amplifiers (289) . . . Digital-to-4-to-20mA Converters for Process Control . . . and these New-Product Briefs: 12-Bit A/D Converter Converts at 5MHz (MOD-1205); Fast-Settling ECL DACs (HDS Family - 10 Bits in 15ns!); 8-Bit Low-Cost Really Complete μ C-compatible DAC (AD558); High-Resolution (16, 18-Bit) DACs and Deglitcher (DAC1136/1137/1138, Deglitcher IV); 1.2V Two-Terminal Reference (AD589); Fast FET Op Amp (AD544) . . . Analog Devices Names Division Fellows: A. Paul Brokaw and Barrie Gilbert . . . Application Note: CMOS DACs in the Voltage-Switching Mode . . . Across the Editor's Desk: Doubts About 15-Bit A/D Converter Configuration Resolved; Statistical ADC Testing . . . Worth Reading: New Digital Panel Instrument Catalog . . . Plus Authors, Potpourri, etc. Use the reply card for your free copy, or for information on any of the above items.

NEW ARTICLE-REPRINTS AVAILABLE . . . "PCM Signal Codecs for Video Applications," by Walter A. Kester. *SMPTE Journal*, November, 1979, Volume 88, pp. 770-778. Subheadings include: Video A/D Conversion Techniques, Dominant ADC Error Sources, Composite Video D/A Conversion Techniques, Video DAC Error Sources, Analog Testing of Video ADCs . . . "Low-Cost A/D Converter Links Easily with Microprocessors," by M. Tuthill and D. P. Burton. *Electronics*, August 30, 1979 (the AD7574 CMOS ADC, see page 14 in this issue).

PRODUCT NOTES . . . New data sheets are available on these synchro-digital products: SAC1763, SDC1700, SDC1702, SDC1704 . . . The AD7533 12-bit DAC doesn't need the Schottky diode protection indicated for most CMOS DAC types when used with high-speed op amps. It was designed to have insufficient parasitic SCR beta for latchup on large negative startup transients . . . Damage to the outputs of the AD2020 a/d converter may occur if the supply voltage used for open-collector pullup is not strictly limited to +5V dc max . . . For offset within specifications when the AD2023 or AD2023B is used without the optional zero-adjust pot, the user must connect pins 19 and 21 to pin 15 with the pot removed . . . For best results when using the AD2040 temperature indicator, observe these commonsense suggestions: Use twisted transducer/probe leads when the run is more than a foot or two; Avoid proximity of leads to high-power leads - cross at right angles; Use well-regulated filtered supply (e.g., Model 903) - add filter capacitors if poorly regulated supply must be used; Connect ac-powered meters to properly wired outlets or power sources; If performance is questionable, recalibrate using standard procedure, check probe separately or try a replacement, use bypass capacitor from pin 5 to pin 3 on dc-powered meters.

NATURAL ALLIES . . . The AD542 and AD544 monolithic TRIFET op amps and the AD7500 series DACs - because of the AD542's low offset voltage, low power, low warmed-up bias current, high speed, well-behaved inputs (no Schottky protection required), low cost . . . Also the AD544 and audio circuitry (and such digital attenuators as the AD7525 and AD7110) - because of the AD544's low noise and distortion.

ASK THE APPLICATIONS ENGINEER . . . Q. How many Model 289 Sync terminals can be connected together? A. We recommend that only 32 units be jointly sync'd together by this method. We do suggest that if more than 32 units require synchronization, or a multi-card assembly is to be used, each card or group of 32 units should have its own drive - as discussed on the data sheet. (The 289 is a high-performance 3-port isolator-amplifier that can be used singly or in groups, and is synchronized by simply connecting Sync terminals together.)

SOME RECENT PRICE CHANGES . . . Quantity prices on orders for more than four video ADCs - MOD1005, MOD1020, MOD1205 - have been greatly reduced. For details, consult the nearest sales office.

FOR HIGH SPEED HYBRIDS, WE'RE ONE FAST COMPANY.

No one makes more high-speed data acquisition hybrids than the Computer Labs Division of Analog Devices. Our DAC's, ADC's, track-and-holds, and op-amps are the fastest available anywhere. All feature active laser trimming for improved accuracy, which obviates the need for external parts in most applications. All are available in commercial temperature ranges as well as extended temperature ranges — and all are available processed to MIL-STD-883.

MORE DAC'S FOR GRAPHIC DISPLAY APPLICATIONS.

If you've got a graphic display application, we've probably got your DAC. We make DAC's aimed at ultra-high speed, low glitch applications. They feature TTL or ECL input compatibility, and are available in a wide variety of configurations, such as wide voltage compliance, low impedance current output, voltage output, and composite video output. These DAC's are available with resolutions from 8 to 12 bits with settling times as fast as 10 ns.

Ultra-high-speed DAC's — circle reader service card #54

MOST COST-EFFECTIVE FAST ADC'S AROUND.

With typical conversion times of only 2.2 μ s for complete 12-bit conversion, our hybrid ADC's are the fastest, smallest, most complete successive-approximation A/D converters available. Housed in 32-pin dual DIP packages, they include 8-, 10- and 12-bit resolution versions with TTL compatibility. They feature unsurpassed speed and accuracy and they are very affordable.

Ultra-fast hybrid ADC's — circle reader service card #55

OUR TRACK-AND-HOLDS ARE FAST AND ACCURATE.

The ability of our track-and-holds to accurately capture and hold rapidly changing transient or continuous waveforms is unexcelled. And you can make trade-offs between acquisition time versus droop rate and feedthrough rejection — while maintaining 0.01% linearity. With acquisition times as fast as 20 ns, they offer either ECL or TTL compatible inputs.

Ultra-high-speed hybrid track-and-holds — circle reader service card #56

OP-AMPS WITH SUPER SETTLING TIMES.

Our very high speed wideband op-amps are specially designed to complement our line of high speed data acquisition products. They feature 100 MHz gain bandwidth products, slew rates of 300 V/ μ s, and settling times of 80 ns to 0.1%.

Fast settling Video Operational Amplifiers — circle reader service card #57

For more information on any or all of these high-speed hybrids, circle the appropriate reader service number(s) or call (919) 292-6427.

 **ANALOG DEVICES
COMPUTER LABS**

WAY OUT IN FRONT.