

analog dialogue

A forum for the exchange of circuit technology: Analog and Digital, Monolithic and Discrete

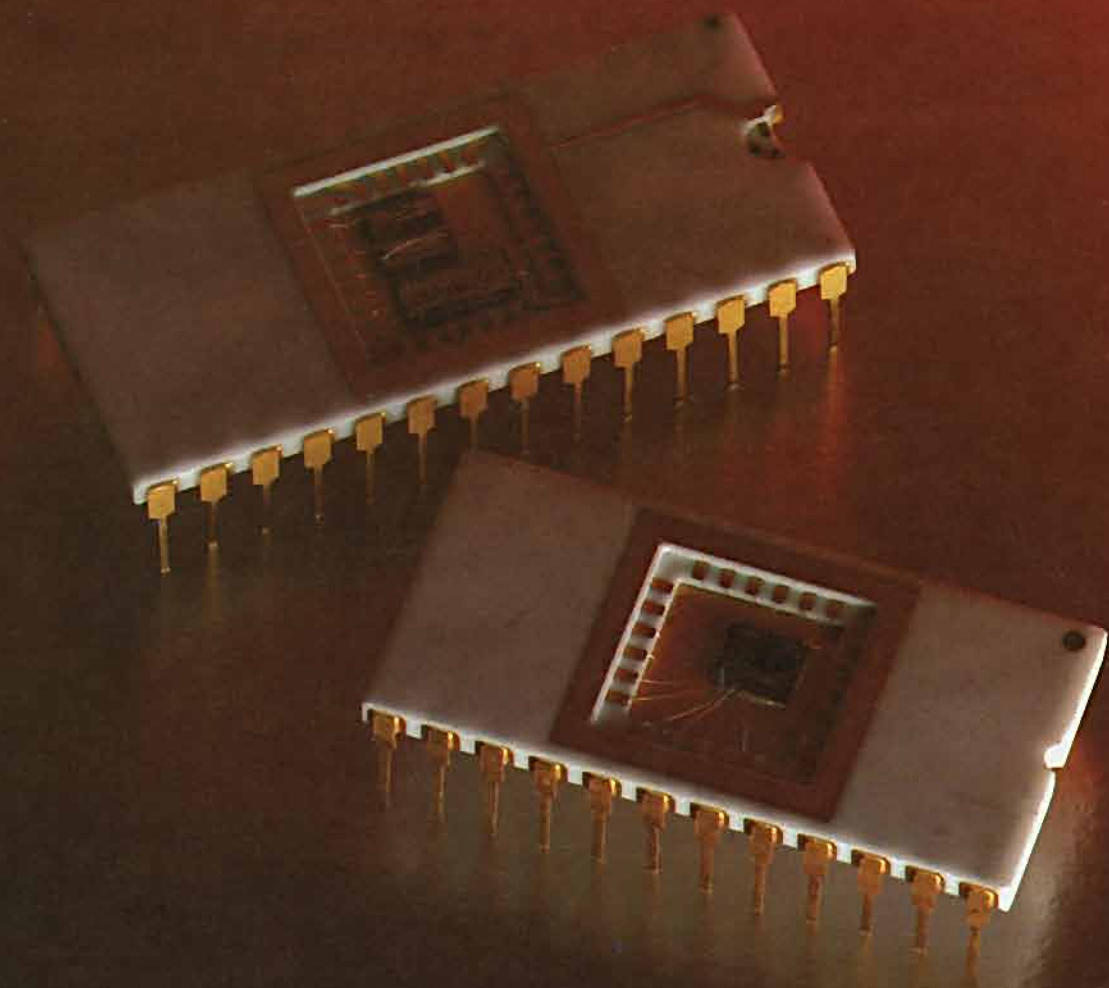

FAST 12-BIT MONOLITHIC D/A CONVERTER CHIP (Page 8)

IS THE KEY TO PERFORMANCE OF 12-BIT 2-CHIP ADC (Page 3)

Complete Contents on Page 3

Editor's Notes

THE DIGITS ARE COMING! THE DIGITS ARE COMING!

This is a perspective on the AD565 and AD574, integrated-circuit breakthroughs introduced in the pages that follow.

In integrated-circuit manufacturing, yield is everything. If all goes well, the voyage down the learning curve can be very profitable for an innovative manufacturer. Improved yields of precision analog circuits involve (1) clever design that makes optimum use of available standard technologies, (2) "racer's-edge" variations of standard processing that maximize yields to a given performance level, and (3) successful introduction of new technologies that greatly increase yield, at the cost of increasingly complex processing.

The first option was obvious, but it still called for innovative designs, such as multiple-emitter transistors; the second involved such techniques as superbeta processing, and doping variations for tradeoffs between speed and breakdown voltage; and the third - with greater risk (and potential reward) - involved new departures, such as dielectric isolation, thin-film on silicon, laser-wafer trimming (LWT), and compatible I²L.

It was the uncharted waters of the third option that our brave little bipolar semiconductor operation embarked upon in 1969. An early innovation was to use on-chip metal-film resistors in critical biasing circuits to make op amps perform more stably. This, combined with patented axially symmetric driver geometries, spawned the high-gain, low-drift AD504 and its successors, the AD510 and the AD517. Finding the thin-film learning curve to be stable, we used computer-controlled lasers for automatic trimming of resistance, first at final assembly, then (as confidence increased), at the higher-payoff wafer stage.

Having successfully produced quad switches, for d/a conversion, we set out to combine three quads on a switch chip, and a compatible set of laser-trimmed resistors on a resistor chip. This was the genesis of the two-chip AD562 12-bit DAC; with an added reference chip, we could produce the three-chip AD563.

Confidence built as we used our thin-film and LWT processes successfully on more and more products: multipliers, op amps, converters, and as we developed stable buried-Zener and band-gap references; a byproduct of the latter was the popular two-terminal current-output temperature sensor, the AD590.

And now, two significant new chips! The AD565, a fast one-chip low-power version of the 12-bit AD563, solves the problem of combining resistors, switches, and reference on a single analog LSI chip, with maximized yield through laser wafer-trimming. The second is a comparator/SAR/control-logic 3-state I²L chip that can be married with a 565 chip in an IC package to produce a true 12-bit, fast, successive-approximation a/d converter (the AD574), with no external components required. Except for the comparator front end (trimmed by Zener-zapping), this is also the first all-digital complex chip from Analog Devices. What is the analog world coming to?



Dan Sheingold

THE AUTHORS

Michael Timko (page 3 and page 8) is Senior Design Engineer at Analog Devices Semiconductor. His photo and a brief biography appeared in DIALOGUE 12-1.

Dr. D. Philip Burton (page 7) is Manager of Development Engineering at Analog Devices B.V. in Limerick, Ireland. He holds a postgraduate degree in control systems and a Ph.D. in logic system design. He has been an independent consultant, Chief Engineer of Infotronics, Ltd., and Lecturer at the National Institute of Higher Education.



Dr. Malcolm "Steve" Stephenson (page 7) is Senior Applications Engineer at ADBV. Previously, he lectured at Trinity College (Dublin) for a number of years, and he consulted on ultrasonics and basic instrumentation. He was graduated from the University of Surrey (England), where he also took postgraduate work towards his doctorate.

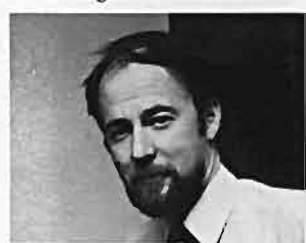

Frank Goodenough (page 10) is Technical Promotion Manager at Analog Devices. His photo appeared in DIALOGUE 12-2.

Lewis Counts (page 14) is Staff Engineer at Analog Devices Semiconductor. His photo appeared in DIALOGUE 9-3.

Richard Frantz (page 14) is Product Marketing Engineer at ADS. His photo appeared in DIALOGUE 9-1.

Janusz Kobel (page 15) is Marketing Manager, signal-conditioning products, for ADI's Instruments and System Group. A native of Poland, he holds an MSEE from Warsaw Polytechnic Institute and an MBA from Boston University. Before joining us, he was employed at Bowmar/ALI and BLH Electronics, where he has developed a number of transducer-oriented process-control instruments and systems.



Dennis McDonnell (page 16) is Senior Staff Engineer at Memory Devices, Ltd., a company 51% owned by Analog Devices, Inc., in East Molesey, Surrey, England. His photo appeared in DIALOGUE 9-2.

(More Authors will be found on page 9)

analog dialogue

Route 1 Industrial Park, P.O. Box 280, Norwood, Mass. 02062

Published by Analog Devices, Inc., and available at no charge to engineers and scientists who use or think about I.C. or discrete analog, conversion, data handling and display circuits. Correspondence is welcome and should be addressed to Editor, *Analog Dialogue*, P.O. Box 280, Norwood, Massachusetts, U.S.A. 02062. Analog Devices, Inc., has representatives and sales offices throughout the world. For information regarding our products and their applications, you are invited to use the enclosed Business Reply card, write to the above address, or phone 617-329-4700, TWX 710-394-6577 or 710-336-0562, Telex 924 491, or cable ANALOG NORWOOD MASS.

COMPLETE 12-BIT 2-CHIP IC A/D CONVERTER

25 μ s Successive-Approximation AD574 Is Fully Bus-Compatible

Versatile Interface Controls Provide Applications Flexibility

by Mike Timko and Peter Holloway

The Analog Devices AD574* is a complete 12-bit integrated-circuit analog-to-digital converter in a 28-pin hermetically sealed dual in-line package. Using a successive-approximations approach, the AD574 performs a complete 12-bit conversion in 25 μ s (35 μ s max). The two complementary chips contain all the necessary circuitry, including a stable buried-Zener reference, d/a converter, comparator, successive-approximations register, three-state output gates, and all the interface logic needed for total self-sufficiency as either a conventional stand-alone ADC or as a memory-managed ("mapped") micro-processor peripheral (Figure 1). The fast, current-output DAC and its reference, on a single monolithic chip, are available separately as the AD565†. Cost of the AD574 is only \$36 (J Grade in 100's).

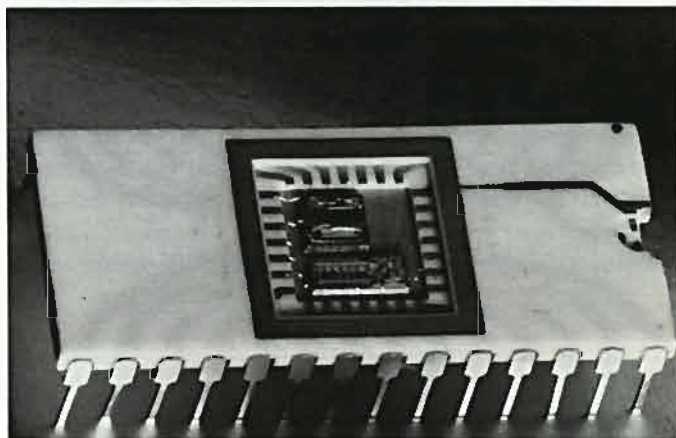

WHY THE AD574?

Digital technology is increasingly being used in measurement, control, communication, and signal processing, in an ever-widening circle of real-world applications, from industrial processes and heavy machinery to automobiles and appliances. The needs for interfacing analog variables in these applications often demand no more than either high-resolution, slow, integrating a/d converters or faster 8-bit devices; but there is an increasing number of applications that call for fast conversion with 12 bits or more of resolution with accuracy, reliable performance, and low cost.

It is manifestly true that the systems engineer would benefit greatly by having all stages, from sensor to processor, combined inside a single IC package. No minor advantage would be relief from the task of dealing with the assembly of pieces of a circuit comprising 0.01% dc accuracy, 25 μ s conversion time, and the implied need for the equivalent of 1.5MHz full-power system bandwidth, 30nV/ $\sqrt{\text{Hz}}$ noise levels, and VHF layout techniques.

The AD574 is a big step towards this goal, solving (as it does)

the problem of designing the interface between the two worlds and relegating most of the remaining design problems to either purely analog or purely digital – and, in most cases, purely routine – considerations.

Designed as a single unit, the AD574 is the most-complete, lowest-cost, and easiest-to-use fast 12-bit IC converter available. Drift with time and temperature are minimized by closely tracking monolithic thin-film resistors and a low-drift, low-noise buried-Zener reference. Excellent absolute accuracy and linearity are achieved by judicious use of both laser (wafer) trimming (LWT) and Zener-zap trimming (ZZT). Noise is minimized by the use of the buried-Zener reference and a controlled-bandwidth-front-end latching comparator. Flexibility is available at both the analog end (choice of ranges and use of the reference), and at the digital end (variety of TTL control logic), implemented in integrated injection logic (I²L). Cost is minimized by manufacturing the ADC as two chips, optimized for size and performance, trimmed at the wafer stage, and combined in a 28-pin integrated-circuit package.

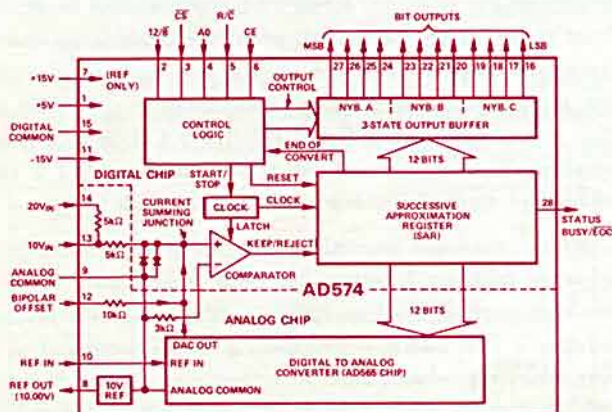

Figure 1. Block diagram of AD574 12 bit A-to-D converter.

IN THIS ISSUE

Volume 12, Number 3, 1978, 20 Pages

Editor's Notes, Authors	2
Complete 12-Bit 2-Chip IC A/D Converter	3
3 New CMOS Monolithic Multiplying DAC's	7
Fast, 12-Bit Monolithic Current-Output D/A Converter	8
Multi-Channel Measurement of Temperature, Pressure, Flow, etc., Made Easy, Economical, and Expedient	10
High-Performance, Low-Cost Bipolar-FET Op Amp	14
Bridge Signal-Conditioning The Easy Way	15
Application Note: Versatile Digital Vector Generators	16
New-Product Briefs:	
3-Chip AD DAC85: Upgrade Systems Without Redesign	18
FET-Input AD545; Precision Low-Drift-&-Noise Op Amp	18
Potpourri	19
Advertisement	20

*For technical data, use the reply card.
†See pages 8 and 9.

Figure 1 is a functional block diagram of the AD574, showing both the analog and the digital sections. The analog chip contains the 10V reference, the current-output DAC, and the bipolar-offset and scaling resistors; the digital chip contains the SAR, control logic, clock, comparator, and 3-state buffer.

The connection between the precision reference and the DAC reference input is made externally. This permits the slaving of several ADC's to a single reference, ratiometric operation, and optional trimming of the scale factor. For bipolar input voltage, the BIPOLAR OFFSET terminal is connected to the reference output to offset the input by half-scale (an external offset trim is optional). The 20V and 10V span inputs permit ranges of 0 to +10V, -5V to +5V, 0 to +20V, and -10V to +10V. Figures 2a and 2b show the connections, including optional trims, for 0 to +10V and -10V to +10V operation.

While many combinations of signals at these inputs will operate the device, each of the apparently redundant inputs has a specific reason for being included and does one kind of job best. For instance, the Chip-Enable pin (CE) has the fastest response of all the inputs. If all the other inputs are in the appropriate states, the width of a pulse at CE to start a conversion need not exceed 300ns. CE also brings the three-state outputs on in the shortest time, about 350ns. Therefore, CE is the most likely to be used to synchronize the AD574 to a microprocessor data bus. Though \overline{CS} (CHIP SELECT) is 100ns slower than CE, it has the correct sense for many common address-decoding schemes.

The READ/CONVERT pin (R/\overline{C}) selects either the conversion mode or the output mode during a μP instruction cycle; or it can control the entire device in the 12-bit stand-alone mode. A conversion starts whenever CE is high, \overline{CS} is low, and R/\overline{C} has gone low. The conversion is edge-triggered; within 400ns the STATUS output goes high (BUSY), the outputs are forced into the off state (if they weren't there already), and all further inputs are ignored until the conversion is complete.

In stand-alone operation, CE and \overline{CS} are wired high and low, and R/\overline{C} is toggled; bringing it low starts a conversion. After 400ns, it can be brought high without affecting the progress of conversion; the outputs will remain inhibited until the end of conversion, then come on. If, on the other hand, R/\overline{C} is held low, the outputs will be held in the off state until R/\overline{C} is returned high, at which time they will be activated.

Once R/\overline{C} has been brought low, a conversion can be initiated by bringing CE high (\overline{CS} low) or \overline{CS} low (CE high). However, one of the three must be cycled before another conversion can take place, even if the output is not to be read out. (Readout is inhibited by bringing CE low or \overline{CS} high, while R/\overline{C} is high or bringing R/\overline{C} low before the end of conversion).

The hard-wired output-format connection, $12/\overline{8}$ selects between 12-bit parallel output and 8-bit multiplexed outputs (left-justified). With $12/\overline{8}$ programmed low, only two output nybbles at a time can be enabled, preventing bus conflicts for parallel-wired multiplexing schemes.

The state of A0 at the start of conversion determines whether the conversion is to be a full 12-bit conversion or an 8-bit "short cycle". The state of A0 when the outputs are enabled determines whether the high or the low byte is selected in 8-bit multiplexed operation. For example, if the result of a 12-bit conversion is 1 0 0 1 0 1 1 0 0 0 1 0, in multiplexed operation (to be described), A0 low outputs 1 0 0 1 0 1 1 0, and A0 high outputs 0 0 1 0 0 0 0 0 on the 8-bit bus.

In memory-managed interfacing, A0 can be viewed as a pair of read-write memory locations for both "read" and "write". A write command at the lower address at the start of conversion produces a full 12-bit conversion; a write command at the upper address produces an 8-bit conversion. A read command at either address when $12/\overline{8}$ is high will result in full 12-bit output data (for a 12-bit conversion); but if $12/\overline{8}$ is low, a read command at the lower address will output the 8 more-significant bits, and a read command at the higher address will output the 4 less-significant bits and four trailing zeros.

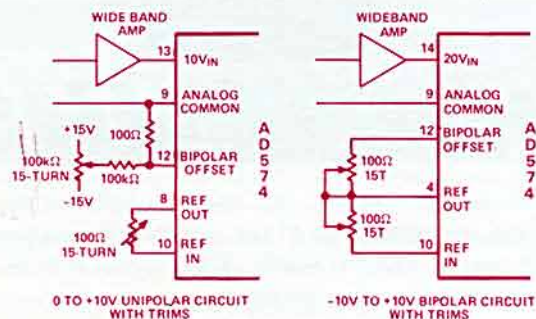

Figure 2.

Besides providing the current available for local use, the +10V ($\pm 25mV$, 20ppm/ $^{\circ}C$) reference can furnish up to 2.5mA for external use when connected for unipolar operation, and 1.5mA in the bipolar connection. A single reference can accommodate two AD574's in bipolar operation or six AD574's in the unipolar mode. If a device's internal reference is not used, the +15V connection, which supplies the reference only, may be omitted.

CONTROLLING THE AD574

The AD574's parallel data output consists of a 12-bit 3-state (1, 0, open) buffer. Depending on the logic inputs and the device wiring, the eight more-significant bits (nybbles¹ A & B), the four less-significant bits (nybble C and zeros at nybble B), or all twelve bits can be enabled. A STATUS (BUSY- \overline{EOC}) output goes high when a conversion is in progress. As will be shown, conversion may be stopped after eight bits ("short cycle") for a tradeoff of resolution for speed.

Five control inputs provide flexible means of controlling both the start of conversion and the choice of output display. Their functions are tabulated below.

AD574 CONTROL TABLE		
CONTROL INPUT	CONVERT FUNCTION	DISPLAY FUNCTION
CE, "Chip Enable" (Clock synchronization in μP applications)	Must be high for a conversion to be initiated.	Must be high for the results of a conversion to appear at the output.
\overline{CS} , "Chip Select" (Address pin in μP applications)	Must be low for a conversion to be initiated.	Must be low for the results of a conversion to appear at the output.
R/\overline{C} , READ/CONVERT	Must be brought low before a conversion (each conversion) can be initiated	Must be high for the results of a conversion to appear at the output
A0 "Address"	Selects conversion mode to be initiated: 12 bits, if low, 8 bits (short cycle) if high	Selects output word in multiplexed conversion: Most significant byte (nybbles A & B) if low, Least significant byte (nybble C and all-zeros at B) if high
$12/\overline{8}$, 12 Bits/8 Bits output format, hard wired to +5V, high, or digital common, low	No function	Output format is 12-bit parallel if high, 8-bit multiplexed if low

¹ See Bibbero, R. J., *Microprocessors in Instruments and Control*, John Wiley and Sons, 1977, page 107" . . . four bits have been termed a nybble (obviously a small byte)."

MULTIPLEXING AD574 ON 8-BIT BUSES

As we have noted, the same output buffers which can present 12-bit parallel data are also designed to multiplex directly into an 8-line microprocessor bus. Multiplexing is accomplished by grounding the output mode pin, 12/8, and paralleling nybble C, which contains the 4 lowest-order bits, with output nybble A, which has the 4 highest-order bits. Wiring 12/8 low prevents simultaneous enabling of A and C, and causes four zeros to appear at B when the low-order word is enabled.

Perhaps the simplest interface configuration, with the 6800 μP , is shown in Figure 3. The AD574 is shown directly connected, with no external control logic, to the data, control, and address buses of the microprocessor. While few systems will ever be this simple, the number of additional component packages required will in general be considerably less than are usually required for interfacing analog signals to μP 's. For larger systems, appropriate decoding between the address bus and $\overline{\text{CS}}$ will be required; a convenience of the AD574 is that $\overline{\text{CS}}$ is of the right polarity for the active-low output of most decoders.

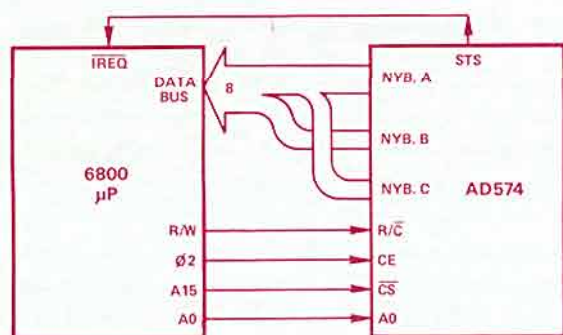

Figure 3. Basic interface between AD574 and a standard 6800 system.

CE is timed to enable the AD574 when phase 2 of the clock, (the bus-synchronizing signal) goes high, as $\overline{\text{CS}}$ goes low when the AD574 is selected. The STATUS line of the AD574 is shown connected to IREQ, the maskable interrupt line of the 6800, it goes low and serves as a means to request attention from the processor after the conversion has been completed. Since this channel is software-maskable, the processor need not service an interrupt routine, but may be programmed to time out the 35 μs needed for conversion instead.

Figure 4 shows the connection of the AD574 to a standard 8080A system, which includes an 8228 system controller. While the 8080A does not produce signals that will operate

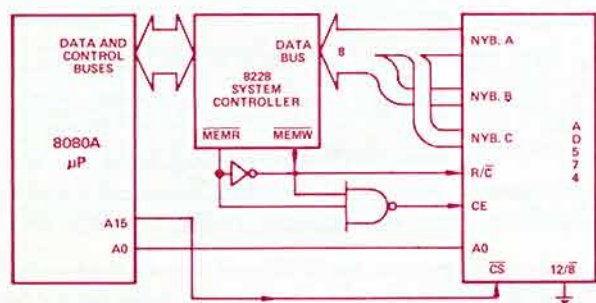
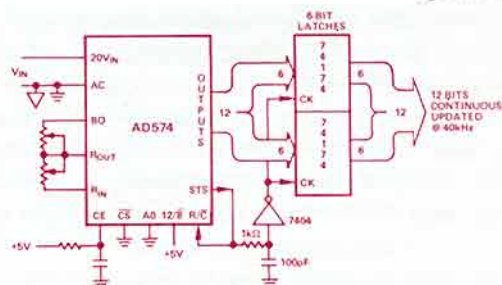

Figure 4. Basic interface between the AD574 and a standard 8080A system.

the AD574 directly, the appropriate signals can be synthesized by a single NAND gate. Address bit A15 is shown connected to the same NAND gate, an alternate way of addressing.

BASIC STAND-ALONE CONVERSION

In the quest for μP compatibility, it is easy to lose sight of ADC application features that are traditionally necessary. One of the oldest—but still quite common—requirements is self-triggered continuous conversion, illustrated in Figure 5.



(a) Block diagram.

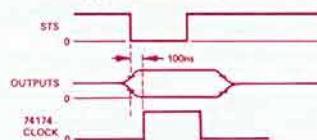

(b) Timing diagram.

Figure 5. Continuous conversion application with dual-rank output latching.

The key to continuous conversion is feeding the STATUS line back to the $\overline{\text{R/C}}$ input. In each cycle, the following chain of events occurs repetitively: As a conversion begins, STS goes high, programming the control logic (via $\overline{\text{R/C}}$) for an output read. The outputs are kept in the off state, as part of the normal internal program, until the conversion is complete. When the data is ready, the inherent timing is such that the outputs automatically come on (in response to $\overline{\text{R/C}}$ high) within 80ns of the low transition of STS, allowing the STS transition to its low (end-of-conversion) state to be used, with a 100ns delay, as a strobe to latch the output data into the 74 latches. The STS transition also initiates another conversion and starts the sequence all over again, with another STS low-to-high transition occurring about 400ns later.

Since the AD574 has a stable latchup mode, which can only be entered during power-up or fault conditions (STS and $\overline{\text{R/C}}$ both coming on low), CE is used here as an initialization control, operating from a power-up pulse, or some other suitable source.

EXTENDING RESOLUTION TO 15 BITS

Real-world signals often have dynamic ranges that greatly exceed the 72-dB span of a 12-bit converter. The manner of performing the conversion depends on the desired relationship between dynamic range, resolution, and accuracy. Obviously, if all of these characteristics must be preserved for a 15-bit linear conversion (32,768 unique codes, each occurring within $\pm 1/2\text{LSB}$ of the ideal analog value), a true 15-bit converter must be used.

However, a true 15-bit converter is not always necessary. For example, if a dynamic range of 2^{15} is desired (i.e., the LSB is 2^{-15} of full scale), but it is not necessary to resolve large signals to better than 2^{-12} , a technique often used is

to employ a programmable-gain amplifier with precise gains of 1, 2, 4, 8, ahead of the 12-bit a/d conversion. The effect of this is to shift the output word by 0, 1, 2, or 3 bits, increasing the size of the word to 15 bits, and providing 15-bit resolution for signals from 2^{-15} to 2^{-3} of full-scale range, 14-bit resolution for signals from 2^{-3} to 2^{-2} of FSR, 13-bit resolution for signals from 2^{-2} to 2^{-1} of FSR, and 12-bit resolution for signals from 2^{-1} of FSR to $(1 - 2^{-12})$ FSR.

A key consideration in many applications is that there be no loss of resolution through missing codes in the vicinity of transitions where gain is switched. Examples of applications where abrupt discontinuities in the transfer curve destroy essential information include digitized audio, detection of visual image contours from photomultiplier-tube outputs, and rate-sensing in liquid-chromatography experiments. If you build a 15-bit ADC by gain-ranging at the input of a 12-bit ADC, then the gain function (including drift and offset) must itself be good to better than 15 bits, to ensure monotonic behavior at the boundaries between the top of one gain range and the midpoint of the next range, which has twice the gain.

A useful way of achieving 15-bit resolution (over the whole range) is shown in Figure 6. It utilizes a precision differential amplifier, an AD574, a microprocessor as the controller, and a rudimentary 3-bit DAC with 12-bit or better accuracy. Here, the gain of the basic a/d conversion never changes from 1.25V full-scale, referred to the analog input. Instead, the 0-10V input signal is dealt with by subtracting multiples of 1.25V (i.e., $10V/2^3$) from the input, searching for the condition where the remainder is between 0 and 1.25V in magnitude. The residual voltage (amplified 8x) is converted by the AD574, which (in effect) interpolates to twelve bits of resolution between the appropriate adjacent segment boundaries (0, 1.25V, 2.5V, . . . 8.75, 10.0V)

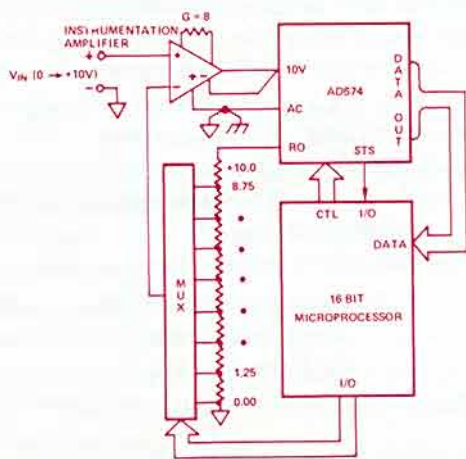

Figure 6. 15-bit ADC application.

The important distinction here is that the 3-bit DAC doing the offsetting need not have 15-bit accuracy. Because the ADC never spans more than one segment at a time, the endpoints will match to the ultimate resolution of the system if the magnitude of the voltage across each of the 1.25V segments agrees with the 1.25V (amplified) full-scale of the converter to within one LSB. Thus, a 12-bit-resolution, 12-bit-accuracy ADC and a 3-bit-resolution, 12-bit-accuracy DAC can team up to make a monotonic 15-bit-resolution, 12-bit-accuracy ADC.

The fastest way to run this system is to implement a successive-

approximation routine for the three range bits in a controller or microprocessor, comparing the output of the AD574 with the digital threshold values, to determine whether to keep or reject each range bit as it is tested. Using this approach, four conversions will be needed, three for range, and one for 12-bit interpolation. The processor (e.g., 8086, 9940) controls the timing and the 3-bit SAR routine, and completes the arithmetic to provide a 15-bit conversion every 100-150 μ s.

The DAC consists of an 8-channel CMOS multiplexer and a string of eight equal resistors matched to within 0.01%. The taps on the divider chain are switched through the multiplexer and applied to the high-impedance subtracting input of the instrumentation amplifier. The AD574's reference is used for both the a/d converter and the feedback DAC, to insure ratio-metric tracking of the two DAC's with time and temperature.

Since we are concerned with 15-bit operation (LSB = 31ppm = 0.3mV), extreme care must be taken to minimize IR drops and avoid ground loops. In Figure 6, we show a high-quality ground at the analog common (AC) pin of the AD574, and all signal grounds are returned to this point separately. If the signal-input low cannot be accurately referenced to the AC pin because of heavy currents flowing through the signal lines—which the designer is powerless to reduce further—then dc common-mode rejection must be incorporated. This can be implemented by connecting the positive output-sense line of the instrumentation amplifier to an inverting-ground sensing amplifier with a gain of 1/8, instead of the AC pin. Of course, all of the usual tradeoffs of noise and bandwidth apply, but remember that a single feedback capacitor alone won't control the noise bandwidth. The reference noise, less than 1mV peak-to-peak in 1MHz bandwidth, can be further reduced by shunting the RO pin with a large tantalum capacitor $C > 0.1\mu$ F, but care must be taken that the equivalent series resistance (ESR) of the capacitor be no more than a few ohms, to maintain loop stability.

A FEW WORDS ABOUT TECHNOLOGY

The photograph on page 3 shows the two complementary chips in the open package. The long, thin chip ($2 \times 5.6\text{mm}^2$) contains the comparator, successive-approximation register, output gates, and control logic; the other chip ($3.3 \times 3.7\text{mm}^2$) is the DAC.

The silicon-chromium thin-film resistors are trimmed by cutting into the tab areas of the resistors with a 0.4 mil He laser, which vaporizes the Si-Cr film. This trimming occurs during functional probe at the wafer stage; a computer actively monitors parameters of interest, and trimming is a real-time feedback event. 22 trims are performed, many to an overall resolution of 0.001%.

The SAR chip requires trimming of the comparator offset only. Currents through a network of diffused resistors are switched by selective automatic "zapping" (melting) of 5 fusible Zener diodes (32 choices) by programmed current overloads, forming a permanent low-impedance path, and making it possible to adjust the comparator offset to within 100 μ V.

Since both chips are manufactured by a linear-compatible I^2L diffusion process, it is feasible (at some future time) to merge the two chips without substantially modifying either the circuitry or the trimming strategy. ▶▶▶

3 NEW CMOS MONOLITHIC MULTIPLYING DAC'S

At \$6 (1000's), 10-Bit-Linear AD7533LN Is Lowest In Cost AD7525 Is 3 1/2 BCD; 8-Bit AD7524 Is Buffered For μ P Applications

by Phil Burton and Steve Stephenson

The AD7500 families of CMOS DAC's* are useful both for conventional d/a conversion and for applications as "digital pots", for precise adjustments of gain in ac and dc circuitry, with simplicity and low cost. Following the recent introduction of the AD7541* laser-wafer-trimmed 12-bit DAC and the AD7523* lowest-cost 8-bit DAC, here are three more members of the clan, each optimized for a class of application: the lowest-cost 10-bit AD7533*, the 3 1/2BCD AD7525*, and the AD7524* buffered 8-bit DAC. All have essentially similar analog properties.

LOWEST-COST 10-BIT AD7533

The AD7533 is a low-cost general-purpose 10-bit 4-quadrant CMOS multiplying DAC. Pin- and functionally equivalent to the industry-standard AD7520, the AD7533 can be used as a lower-cost alternative for old AD7520 sockets or for new designs calling for 10-bit DAC's. Its lower cost is the result of more than four years on the learning curve, the concrete evidence of which is size: the AD7520 chip is more than 55% larger than the new AD7533 chip. Smaller size means higher yield and lower cost. The AD7533 is available in several versions, providing a variety of linearities, temperature ranges, and packages; MIL-STD-883B processing is also available.

BUFFERED 8-BIT AD7524

The AD7524 is a bus-oriented 8-bit CMOS multiplying DAC in a 16-pin package. Many d/a converter applications require the digital data presented to the converter to be latched. The AD7524 has a set of D-type latches that are TTL or CMOS-compatible, and the device may be used with any supply voltage from 5V to 15V (Figure 1).

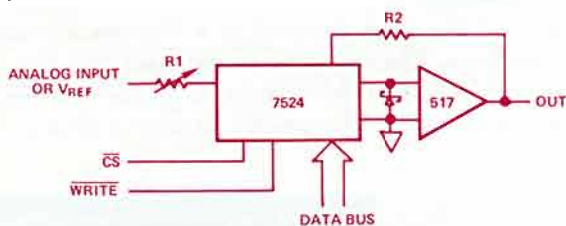

Figure 1. AD7524 application.

In particular, it may be connected directly to the 8-bit bus of a microcomputer and used as a write-only memory. The control-signal requirements consist of active-low "write" and "chip-select". For most microprocessor systems, no additional circuitry is necessary, except for the usual chip-select decoder.

Among the many potential applications of the AD7524 are: programmable power supplies, intelligent instruments, and variable-resistor networks for programmable amplifiers and attenuators.

*For technical data, use the reply card. Specify the devices that interest you; each has its own 6- or 8-page data sheet. A free 46-page CMOS MULTIPLYING DAC APPLICATION GUIDE is also available upon request.

Figure 2 shows a printed-circuit-board layout that was developed for a system where four DAC's are loaded directly from an 8-bit bus. Good grounding practice is essential since use of the 16-pin package requires that analog ground, digital ground and the ladder termination share one pin. The neat separation of the high line-density digital circuitry from the grounded-plane analog circuitry is facilitated by the optimized pin layout of the AD7524 (similar to that of our other M-DAC's).

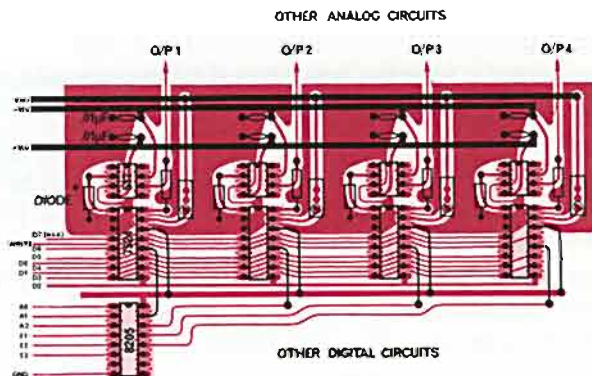

Figure 2. Printed-circuit board layout to accommodate four AD7524's.

AD7525 3 1/2 BCD DIGITAL POTENTIOMETER

The AD7525 is the World's first 3 1/2-digit CMOS single-chip DAC. Its BCD coding opens up a world of low-cost applications in the control of dc and ac gains. With it (and an op amp chosen for the appropriate frequency, power, and signal range), you can set any gain from 0 to 1.999V/V, in steps of 0.1V/V, with an absolute gain error less than 0.2% at 25°C and 0.3% over the operating temperature range, without calibration. With external trim resistance, the 25°C accuracy can be greatly improved.

The digital control, excellent repeatability, and 0.2% accuracy make the AD7525 an ideal replacement for 10-turn potentiometers or thumbwheel-switch voltage dividers using discrete networks. Furthermore, the gain can be controlled remotely, by either manual switch setting, or by a source of automatic digital information.

The AD7525 is packaged in an 18-pin plastic or ceramic DIP and is available for a choice of temperature ranges, including MIL-STD 883B processing. Price in 100's (AD7525KN) is \$12.00. ▶▶▶



FAST, 12-BIT MONOLITHIC D/A CONVERTER

Current-Output AD565 Has Internal Buried-Zener Reference; Monotonic Over Temperature; Settling Time Less than 400ns

by Pete Holloway, Mike Timko, and Dave Kress

The technological triumph introduced elsewhere in these pages, the 12-bit AD574* 2-chip successive-approximation a/d converter, would not be possible without the AD565† 12-bit monolithic DAC chip. The AD565 is a complete current-output 12-bit d/a converter, with 200ns (400ns *max*) settling time to within $\pm 1/2$ LSB.

The AD565 responds to positive-true digital inputs from 5V TTL/DTL and CMOS, and provides a nominal output span of 2mA full-scale. Matched and tracking application resistors on the chip provide a variety of single-ended and bipolar output voltage ranges – when the device is used with an external operational amplifier – or input ranges, in a/d conversion.

All AD565's are guaranteed to be monotonic over the entire operating temperature range (0° to $+70^{\circ}\text{C}$ or -55°C to $+125^{\circ}\text{C}$), and the premium versions (AD565K/T) are guaranteed to be linear to within $\pm 1/2$ LSB over those temperature ranges. It is worth noting that the AD565 achieves its fast, stable response without excessive dissipation – 345mW *max* guaranteed, including the reference.

Packaged in a 24-pin plastic or ceramic dual in-line package, it has a pinout similar to that of the earlier (and slower) AD563. However, being monolithic, the AD565 is available at considerably lower cost, e.g., \$16 in 100's for the plastic-packaged AD565JN/BIN.

WHAT'S IN THE AD565

Figure 1 shows a simplified block diagram of the AD565, connected to an external op amp for 0 to +10V unipolar voltage output. The diagram shows the connections to the 10V precision reference, the stable, high-speed reference amplifier, and the application resistors. The internal block labeled "DAC" contains the network of laser-wafer-trimmed Si-Cr resistors and the fully differential non-saturating high-speed precision NPN current switches.

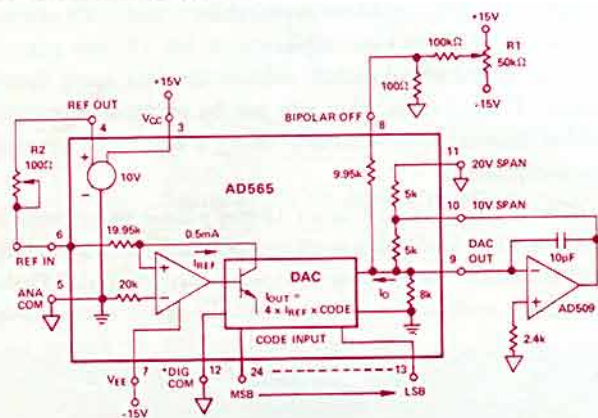

Figure 1. AD565 connected for 0 to +10V output.

The buried-Zener reference is laser-trimmed to $10.0\text{V} \pm 1.0\%$. The 10V connection is brought out to a terminal, permitting it to be connected externally to the DAC's REF IN terminal, via either an adjustable scale-trim resistor, or a fixed 50 Ω resistor (if absolute accuracy is not important consideration). The bipolar-offset input can also be connected to the REF OUT terminal, via a bipolar offset trim adjustment (if desired). The reference can provide 1.5mA of external capacity when fully utilized internally, or 2.5mA externally in unipolar DAC applications. Thus, from two to six DAC's can share a common internally derived reference in applications where tracking is important. When the DAC is used with the internal reference, the max output temperature coefficients (AD565T) are: 15ppm/ $^{\circ}\text{C}$ for gain, 10ppm/ $^{\circ}\text{C}$ for bipolar zero, and 2ppm/ $^{\circ}\text{C}$ for unipolar zero.

The thin-film application resistors permit the AD565 to be connected for these additional output ranges: 0 to +5V, -2.5V to +2.5V, -5V to +5V, and -10V to +10V. Alternatively, the wide output-compliance range (-1.5V to +10V) makes the use of external load resistance feasible where high speeds (without the added time delay of an op amp), output sign inversion (via a follower amplifier), or a/d conversion are desired.

THE AD565 AS A FAST DAC

The high-speed NPN current-steering switching cells and the internally compensated reference amplifier of the AD565 are specifically designed for fast-settling operation. The typical settling time to $\pm 0.01\%$ ($1/2$ LSB) for the worst-case transition (major carry or full-scale step) is less than 250ns; the lower-order bits all settle in less than 200ns.

The full-transition characteristic is shown in Figure 2. There is about a 6-8ns delay, followed by a 10ns rise time and but little overshoot. The transition in the other direction shows approximately a 20ns delay, prior to a 10ns fall time. The slewing characteristics for smaller transitions show a similar characteristic.

INPUT DRIVE
0 TO 5 VOLTS

OUTPUT SIGNAL
1 DIVISION = 1mA

HORIZONTAL SCALE
10ns/DIV.

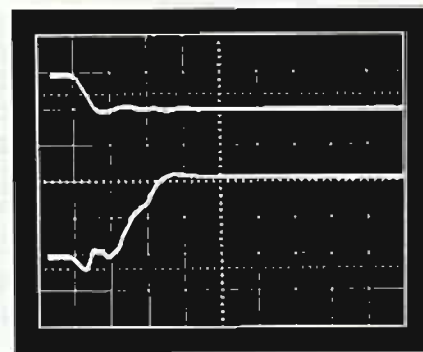

Figure 2. Full scale transition.

*See page 3. For technical data, use the reply card.
†For technical data, use the reply card.

The fine detail of the full-scale settling characteristic is shown in Figure 3. (The equipment and circuitry used to make the

measurements add about 50ns to the actual device performance.) After slewing, the signal slows to within 10 LSB's in 150ns, reaches 1/2 LSB in about 200ns, and completely settles within 400ns. The oscilloscope plots shown in Figures 2 and 3 were made with the AD565 driving directly into an equivalent 50Ω load; the signal was amplified by a low-capacitance MOS-input UHF amplifier. The waveforms show the worst-case situation, a full-scale transition.

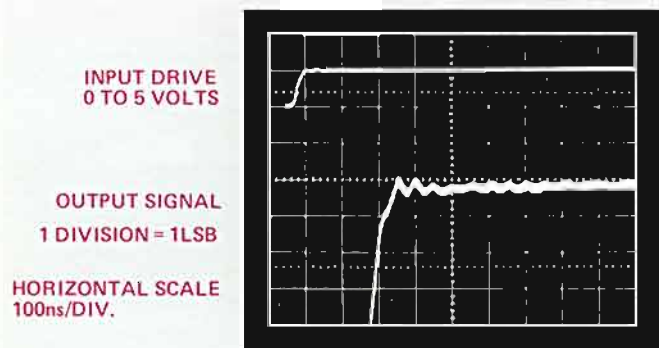
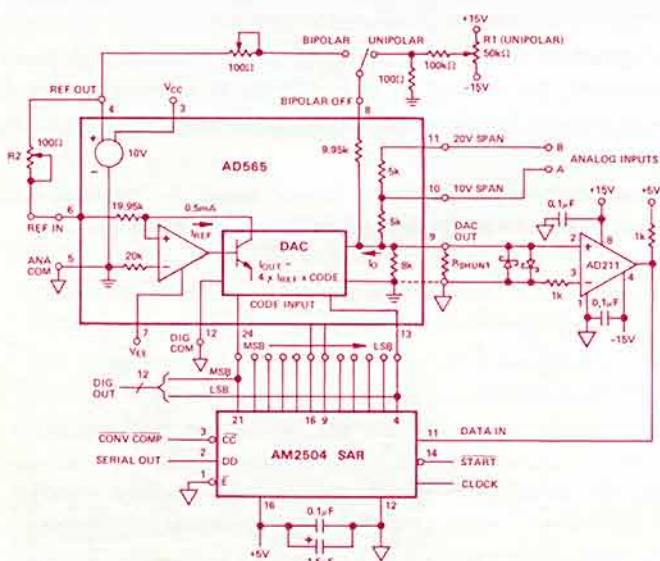

Figure 3. Settling characteristic detail.

APPLICATIONS

The AD565 is suitable for all applications requiring a fast, accurate, low-cost, 12-bit d/a converter in a small package. As its use in the AD574 indicates, the AD565's high speed and small errors make it especially useful in a/d conversion. An a/d converter having better than twice the speed of the AD574 can be built using the AD565 and external circuitry comprising standard parts. The circuit in Figure 4 will complete a full 12-bit conversion in 10μs (unipolar or bipolar).



INPUT RANGES

Unipolar	Bipolar	Connect	Equiv DAC Z _{OUT}
0 TO +10	±5	INPUT TO A	2.35kΩ
0 TO +5	±2.5	INPUT TO A	1.90kΩ
0 TO +20	±10	INPUT TO B B TO DAC OUT	3.08kΩ

Figure 4. Fast precision analog to digital converter.

For fastest operation, the impedance at the comparator summing node must be minimized. However, decreasing

the impedance will reduce the voltage signal to the comparator, and, at an equivalent impedance of 1kΩ (1 LSB = 0.5mV) performance will begin to be sacrificed. The internal resistance of the DAC, which appears in parallel with R_{SHUNT}, depends on the input configuration, as the table shows.

An even faster converter can be constructed by using higher-performance external components, since the limiting factor is the settling time of the DAC: about 250ns for the MSB and 200ns each for the lower-order bits. In high-speed DAC applications, the 50ns max 10%-90% rise time ensures that "glitch" energy is small, a considerable advantage in display applications; the typical unfiltered "glitch" charge is of the order of 5pC at the major carry.

Though designed for positive-true applications, the AD565 can be used for applications in which the digital input is complementary binary, without the addition of inverters. This is done, as shown in Figure 5, by connecting the 10V span resistor to the 10V reference and the DAC output to a noninverting amplifier. The 8kΩ DAC output resistance and the 5kΩ span resistor form a divider which will apply full-scale output voltage, about 6.15V, to the input of the amplifier. For 10V full scale, the feedback gain of the amplifier is adjusted appropriately. ▶▶▶

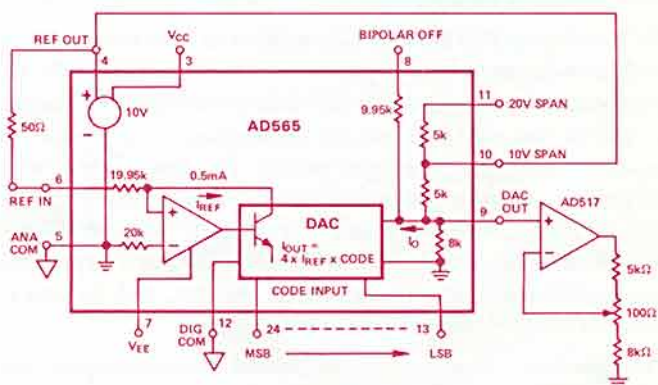
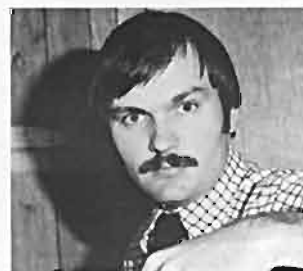

Figure 5. Complementary output DAC

THE AUTHORS

Peter Holloway (see also page 3) is Senior Design Engineer at Analog Devices Semiconductor. He has designed high-speed analog circuits at the MIT Artificial Intelligence Laboratory, operated as a consulting engineer, and founded Compumod, Inc. Having attended Northeastern University, he is currently continuing his education with graduate and undergraduate courses via MIT's Tutored Video Instruction Program.



David Kress, a frequent contributor to *Analog Dialogue*, is Product Marketing Specialist at ADS. His photograph appears in DIALOGUE 10-1.

MULTI-CHANNEL MEASUREMENT AND DISPLAY

Of Temperature, Pressure, Flow, Weight & Strain

Made Easy, Economical, and Expeditious

by F. Goodenough

With a few exceptions, measurement of the basic physical phenomena characterizing process or manufacturing operations requires that small, low-level voltages and currents be dealt with. This usually calls for signal conditioning, precision amplification, and – if digital display or processing is involved – a/d conversion and display circuitry. Expensive multi-channel data loggers are available, but even they usually require additional signal conditioning. This latter function is well-performed by Analog Devices' new 2BXX Series of signal-conditioning modules*.

However, many applications, such as small batch processes, pilot plants, experiments, and test stands may only require the measurement of a few parameters, with accuracy, dynamic range, and resolution in the vicinity of 1:1000 (10 bits, or 3 to 3 1/2 digits). In most of these applications, minimum cost is demanded (even if not demanded, inflation requires that costs always be considered).

We have recognized these requirements and have been industriously developing a line of products to make life easier for the instrumentation engineer – whether he considers himself novice or expert (on electronic circuit techniques). The former can expect to save time, the latter money. The first of these products was a 6-channel scanning digital-panel-meter thermometer, the AD2036†, which operates – completely self-contained – with most of the popular thermocouples: J, K, or T. It provides pre-amplification, linearizing, digital readout, and manual or automatic selection among six input channels.

This product, based on conventional thermocouples, was followed by a technological breakthrough in temperature sensors for the -55°C to $+150^{\circ}\text{C}$ range: the AD590†, a low-cost, precision, linear, high-level 2-terminal current-output device capable of being read out by a low-cost DPM (such as

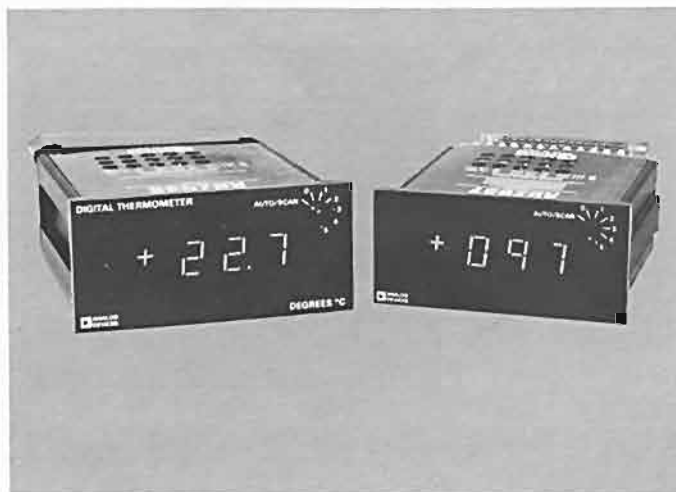

the AD2026) with the addition of a few external components. In the last issue of this Journal, we reported on a low-cost digital thermometer (formed in this way), the AD 2040.†

TWO NEW SCANNERS – THE AD2037 & AD2038

The AD2037† Voltmeter provides six, true-differential (floating/isolated) inputs, which can be connected to provide a full-scale range of ± 199.9 millivolts or ± 1.999 volts, with respective resolutions of 0.1mV and 1mV.

The AD2038† Thermometer is designed to read the outputs of up to six AD590 integrated-circuit two-terminal high-level temperature transducers. A 3/16" OD stainless-steel probe accessory, the AC2626,† with AD590J/K/L/M incorporated, is available in lengths of 4" and 6" for measurements requiring probes.

These instruments are both derived from the AD2036 and retain all of its basic post-front-end features (Table 1).

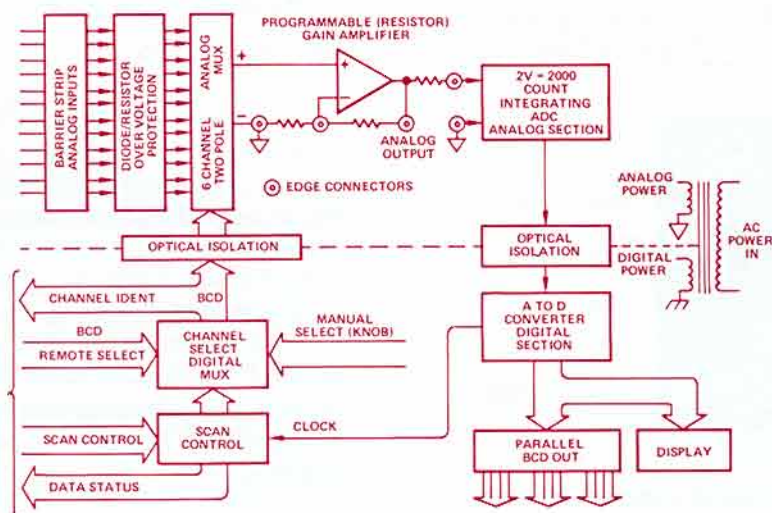

Figure 1. Simplified block diagram of the AD2037 Six-Channel Scanning Digital Voltmeter.

*See page 15.
†For technical data, use the reply card.

†For technical data, use the reply card.

TABLE 1. COMMON FEATURES OF SCANNING METERS
AD2036, AD2037, AD2038.

CHANNEL SELECTION

Front-panel switch-selection of individual channels or continuous scan of 6 channels

Selection of channel or control of scan from a remote point, using a 3-wire BCD code

OUTPUTS

Data: Parallel BCD

Channel Identification: Parallel BCD

Reference: +6.4V ± 1% @ 50µA (AD2037 only)

Analog: 0 to 2V, @ 1mA, proportional to V or T

INPUT

Optically Isolated – Can withstand 250V common-mode

User full-scale range programmable to ±6V

Automatic polarity indication

250MΩ input impedance

Overvoltage: ±30V on any channel and between channels

MECHANICAL

Less than 4" wide, 1 3/4" high, 6" deep (100mm x 42mm x 147mm)

1.25lbs (0.57kg)

Connectors: Two, 30-pin card edge

POWER OPTIONS

AC: 117V, 220V, 100V, 240V (±10%), 50 to 400Hz

INTERFACING

Three outputs (including clock) and eight inputs allow operation with practically any type of digital devices or equipment, including printers, microprocessors, and SERDEX* SERIAL Data-EXchange modules.

WHAT IS THE AD2037? WHAT CAN IT DO?

The AD2037 is essentially a 6-channel scanning 3 1/2-digit integrating digital panel meter, with true-differential input. Its analog input and digital control circuits are diagrammed in block form in Figure 1. In its simplest application, it can be used to monitor continuously millivolt-level voltages at six different points within a piece of equipment or a system. Maximum linear input voltage is ±6V. Above this level, input signals are clamped to ±6.5V with protection diodes.

The basic full-scale range is 199.9 millivolts. To change it to 1.999V, connect a jumper between pins A and 4 of the edge connector at the rear of the unit. Figure 2, which indicates how the scaling works, is a simplified schematic of the programmable-gain amplifier, which operates between the analog multiplexer and the a/d converter. An AD517* low-drift, high-gain IC op amp is connected as a follower with a gain of 10. When the input is ±200mV, the analog output, and the input to the ADC, is ±2V. A jumper across the feedback resistor, R_F, reduces the gain to unity, providing a full-scale range of ±2V.

Since many important applications of the AD2037 are in special-purpose instruments or systems, the ability to produce a display or an analog output that reads in engineering units is of great importance. It can be achieved, without digital program-

*For technical data, use the reply card.

ming, by simply setting the analog gain appropriately. This is provided for by the availability of the op-amp gain-setting points at pins on the rear edge-connector, P2 (Output: Pin A, Summing Point: Pin 4, "Common": Pin 1). Permanently connected between these points are input and feedback resistors (R_{IN} = 22.5kΩ, R_F = 203kΩ). To trim the gain to exactly 10.00 or to adjust for other gains, an external resistor, R_X, is added in parallel with the feedback resistor and/or another resistor, R_Y, is paralleled with the grounded resistor, to provide gain according to the equation:

$$G = 1 + \frac{R_F'}{R_{IN}'}$$

where R_F' is the parallel value of R_X and 203kΩ, and R_{IN}' is the parallel value of R_Y and 22.5kΩ.

For gains less than 1.00 (i.e., for inputs between ±2V and ±6V, or for scaling down to engineering units), the amplifier gain is set to unity by shorting R_F, and the AD517 output is attenuated by a resistive divider consisting of R_A (internal) and R_Z (external). The calculation of this ratio is but one of the many useful bits of information to be found on the data sheet, along with detailed descriptions and timing diagrams for the digital control and output circuitry.

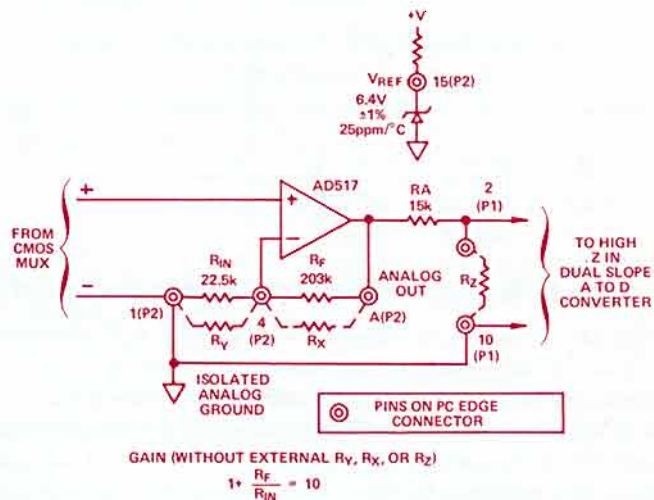

Figure 2. Scale-factor circuitry in the AD2037—internal and external.

AD2037 APPLICATIONS

Beyond simple measurement of dc voltages, the AD2037 is particularly valuable for interfacing a variety of transducers, i.e., providing signal conditioning, with the aid of a few external components.

TEMPERATURE MEASUREMENT More people measure temperature, more often, and for more reasons, than all other physical phenomena put together. Yet, interestingly enough, there are only a few basic devices which convert temperature to electrical quantities. (Compare it with flow, for which there are as many transduction techniques as there are ingenious designers.) The three most-used temperature transducers are the thermocouple, the platinum resistance thermometer (RTD), and the thermistor. Coming up fast to join them is the semiconductor sensor (AD590). The AD2036 operates with thermocouples, the AD2037 with RTD and thermistor, and the AD2038 with the AD590 semiconductor sensor.

Platinum Resistance Thermometer The platinum RTD is simply a wirewound platinum resistor with a stable, linear positive temperature coefficient of approximately $0.39\%/^{\circ}\text{C}$ at 0°C . The standard resistance value is 100Ω at 0°C . Depending on physical construction and the application, the RTD can be used from -270°C to $+850^{\circ}\text{C}$. Indeed, it is the international Standard for temperature measurement from -270°C to $+660^{\circ}\text{C}$.

While often operated in a 3-lead Wheatstone bridge, it performs with improved linearity* when driven by a constant current, while the voltage across it – a function of absolute temperature – is monitored by a high impedance; an AD2037 is shown in this application in Figure 3. Conversion from absolute temperature (kelvin) to Celsius or Fahrenheit requires an offset, which is obtained from the reference output, via R_O to the summing point, while R_G sets the scale constant.

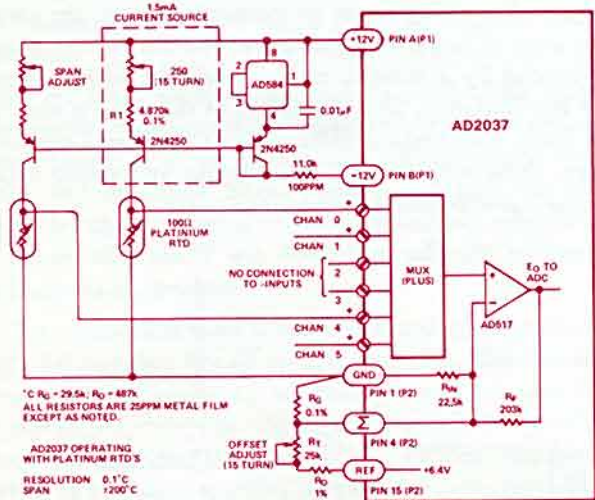

Figure 3. Application of the AD2037 with Platinum RTD's.

The circuit shown in Figure 3 can provide 0.1° resolution ($^{\circ}\text{C}$ or $^{\circ}\text{F}$, depending on the values of R_G and R_O). Each of the six RTD's is excited by a precision 1.5mA constant-current source constructed with a 2N4250 transistor, a $4.87\text{k}\Omega$ resistor, and a 250-ohm trim potentiometer to set the exact full-scale span. The reference for the excitation currents is provided by the AD584 multi-reference†, connected as a current source in series with the 2N4250 and an $11\text{k}\Omega$ resistor.

Here is how the values of R_O and R_G are arrived at to provide a resolution of 0.1°C (200°C span); this will help you in calculating values for different spans and resolutions:

Since the resistance tempo of the RTD is $0.385\%/^{\circ}\text{C}$, the 100Ω device will change $0.00385/^{\circ}\text{C} \times 100\Omega \times 0.1^{\circ}\text{C} = 0.0385\Omega$, for a 0.1°C change. Multiplying by the constant excitation current of 1.5mA, the voltage change is $0.058\text{mV}/0.1^{\circ}\text{C}$. Since the resolution of the DVM is 1mV, the RTI voltage must be amplified by $1\text{mV}/0.058\text{mV} = 17.3\text{V}/\text{V}$.

The offset voltage at the AD517 output that must be nulled to provide a reading of 0 at 0°C is $1.5\text{mA} \times 100\Omega \times 17.3 = +2.6\text{V}$. Offsetting is accomplished by looking at the op amp as a current-to-voltage converter, which provides an output voltage increment, E_O , corresponding to an input current increment, I_{IN} , $E_O = -I_{IN}R_F$. In this case, R_F is the internal

*The resistance-temperature function is not perfectly linear, but it is sufficiently so for many practical purposes.
†For technical data, use the reply card.

$203\text{k}\Omega$ feedback resistor, and I_{IN} is the current determined by R_O (and trim resistor R_T), connected between the $+6.4\text{V}$ reference output and the AD517 summing point. Thus,

$$E_O = -I_{IN}R_F = \frac{6.4\text{V}}{R_O + R_T} R_F$$

$$R_O + R_T = \frac{6.4\text{V}}{2.6\text{V}} 203\text{k}\Omega = 500\text{k}\Omega$$

Now, R_G can be calculated:

$$\text{Gain} = 1 + \frac{R_F (\text{internal})}{R_{IN}}$$

where the effective R_{IN} is the internal R_{IN} ($22.5\text{k}\Omega$) in parallel with $(R_O + R_T)$ in parallel with R_G . The value of R_G works out to $29.5\text{k}\Omega$.

In summary, the AD517 is connected as a differential amplifier measuring the difference between the RTD voltages and the fixed offset voltage. The exact sensitivity of each RTD channel is set by the 250Ω pot in series with the emitter of each 2N4250.

Thermistor One's initial reaction to the suggestion of a thermistor for precision temperature measurement may be quite negative. How could such a nonlinear device be at all useful? However, it has many advantages, among them low cost, high sensitivity, and fast response. Furthermore, in recent years, several manufacturers have introduced "linear thermistors". These comprise a network of linear and nonlinear TC devices in a single package which can provide precision measurement over (say) a 100°C range. The AD2037 data sheet shows how a Yellow Springs PIN 44201 would be applied.

STRAIN-GAGE TRANSDUCERS The AD2037 is capable of providing excitation and readout for the broad range of transducers based on the ubiquitous strain gage. These include direct connection to a one-, two-, or four-gage bridge, and any of the transduction functions which use it. Just a few of the measurements made with strain gages are pressure, force, flow, acceleration, level, and weight. The circuit of Figure 4 represents a typical application which takes full advantage of the true-differential input capability of the AD2037. This application is based on a particular pressure transducer. To interface with other devices, of greater or lesser sensitivity, the gain of the AD517 can be set as required.

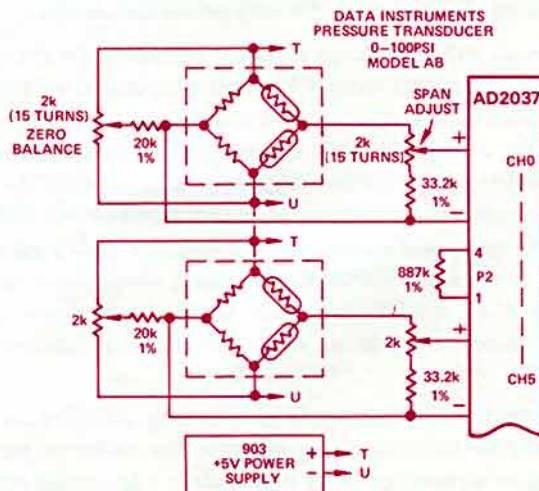

Figure 4. Application of the AD2037 with bridge-type pressure transducer.

PROCESS MONITOR In industrial processes, measurements of all kinds are often normalized to the 4-to-20mA current-transmitter range. The AD2037 can provide scanning and digital readout for six (6) such standard 4-20mA current loops as shown in Figure 5. The AD2037 is programmed for 0-100.0% Readout. Other readout ranges can be accommodated by changing the Gain and Offset programming resistors.

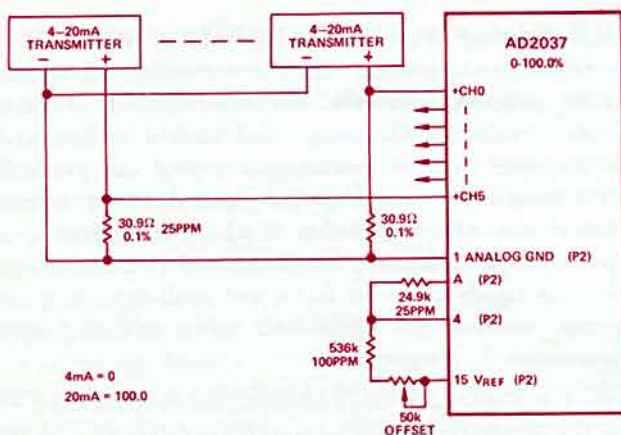

Figure 5. Process-monitor application.

WHAT IS THE AD2038? WHAT CAN IT DO?

In simplest terms, a single AD2038 provides the user with a tool to measure six temperatures in the range of -55°C to $+150^{\circ}\text{C}$ (-67°F to $+200^{\circ}\text{F}$) at six different remote points scattered over an area 5 kilometers (3 miles) square. Resolution is 0.1°C or F. A twisted pair, of virtually any gage or type of insulated wire, is all that is required to connect the measurement locations and the AD2038. This class of performance is possible because the AD590 acts as a current source having a sensitivity of $1\mu\text{A}/^{\circ}\text{C}$; the current is numerically equal to the absolute temperature (kelvin). The AD2038 provides the excitation, offset, and readout.

Figure 6 shows the circuitry that provides the excitation for and reads the output of six AD590's. Each of the remote sensors must have at least 4V across it to function properly. The AD2038 can provide 7.5V of excitation, as shown for

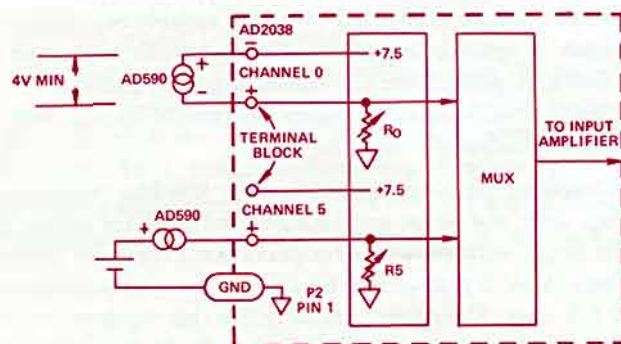

Figure 6. Applying the AD2038 six-channel scanning thermometer with AD590 two-terminal electronic temperature sensors.

Channel 0, or a remote battery (or source of higher voltage – up to 44V – if necessary, because of line drop) may be used as shown for Channel 5. The AD590 will operate continuously for the shelf life of a 6V carbon-zinc lantern battery. Since the AD590 is a current source, there is no need to consider line-

or contact resistance at any point. Therefore, the user may connect a variety of relays, switches, connectors, or even isolation resistors in series with the AD590 and the AD2038 inputs, as long as $\geq 4\text{V}$ is available at the device for excitation. At the AD2038, the current from each AD590 is passed through an adjustable resistor (available to the user for trim) to convert to voltage for input to the AD2038's ADC and display.

ACCURACY

As is characteristic of transducer interfacing, system accuracy is a function of both the AD2038 and the AD590 sensor, of which there are currently four precision grades. The AD2038 itself has a digitizing error of $\pm 0.1^{\circ}$ (F or C). AD590 accuracy is specified in four ways (Table 2).

1. Uncalibrated error at 25°C . This is the error as delivered to you, at 25°C . Specifications 2, 3, and 4 apply over the full operating range of -55°C to $+150^{\circ}\text{C}$ (-67°F to $+200.0^{\circ}\text{F}$ – maximum reading of the AD2038):
2. Uncalibrated error over this operating range (Buy it and wire it in).
3. Error over the operating range when calibrated at 25°C (Buy it, wire it in, calibrate at 25°C).
4. Nonlinearity over the operating range.

Table 2. AD2038 ERROR SPECIFICATION (MAX, INCLUDING AD590)

Specification Class	AD590JH	AD590KH	AD590LH	AD590MH
1	$\pm 5.2^{\circ}\text{C}$	$\pm 2.7^{\circ}\text{C}$	$\pm 1.2^{\circ}\text{C}$	$\pm 0.7^{\circ}\text{C}$
2	$\pm 10.2^{\circ}\text{C}$	$\pm 5.7^{\circ}\text{C}$	$\pm 3.2^{\circ}\text{C}$	$\pm 1.9^{\circ}\text{C}$
3	$\pm 3.2^{\circ}\text{C}$	$\pm 2.2^{\circ}\text{C}$	$\pm 1.8^{\circ}\text{C}$	$\pm 1.2^{\circ}\text{C}$
4	$\pm 1.5^{\circ}\text{C}$	$\pm 0.8^{\circ}\text{C}$	$\pm 0.4^{\circ}\text{C}$	$\pm 0.3^{\circ}\text{C}$

AD590

Price (100's)	\$1.95	\$3.95	\$7.95	\$17.95
---------------	--------	--------	--------	---------

A cursory analysis of these specifications will show that if the user has the capability of calibrating his sensor at 25°C , he can have a precise, low-cost device, using the AD590J. On the other hand, use of the AD590L provides a relatively low-cost, precise measurement, without spending the time and money required for calibration.

CHANNEL IDENTIFICATION

We've shown a number of applications of the AD2037 and the AD2038, emphasizing the versatility of its analog circuits. The digital indication and control circuitry are equally as flexible and useful. For example, to display the channel being looked at, the circuit of Figure 7 can be used to decode and drive an LED display or a printer. ▶▶▶

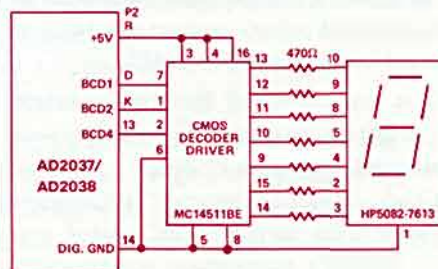

Figure 7. Channel identification using a 7-segment numeric indicator.

HIGH-PERFORMANCE, LOW-COST BIPOLAR-FET OP AMP

AD542K Has $V_S=1mV_{max}$, $Tempco=10\mu V/^{\circ}C_{max}$, $I_b=25pA_{max}$

In Hermetic TO-99 Metal Can, Price is Only \$3.50 (100's)

by Lew Counts and Rich Frantz

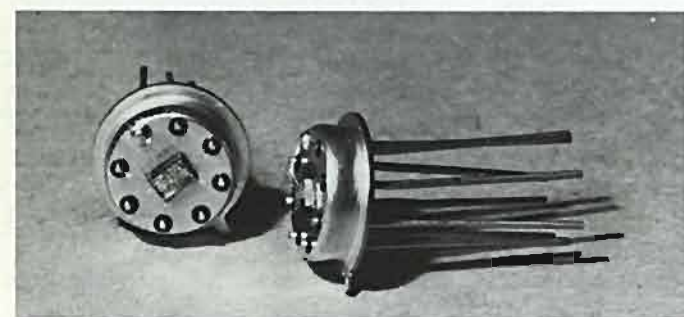

The AD542* is a monolithic FET-input operational amplifier in a TO-99 hermetically sealed metal can. The use of advanced bipolar-FET (bifet) technology, using ion-implantation, combined with laser-trimming at the wafer stage and user-oriented design, results in the highest performance available from amplifiers of this class. Here are a few items to consider:

- Bias current of the AD542K/L is only 25pA max; as with all Analog Devices op-amp designs, the max bias current of the AD542 is guaranteed at either input and after warmup at 25°C ambient.

- V_{OS} is laser-trimmed to within 0.5/1/2mV (L,K,J), making external trimming unnecessary for most applications. The specification applies to warmed-up units (which is the way you tend to think about such specs).

- V_{OS} tempco is guaranteed at 5 $\mu V/^{\circ}C$ (L) without external offset trimming.

- Guaranteed minimum gain of 300,000V/V with 2k Ω load, $\pm 10V$ out (K/L/S) permits high-accuracy applications with substantial gains. Open-loop gain spec is unaffected by offset nulling.

- Low noise (2 μV p-p, 0.1-10Hz), as well as excellent bias current, offset, drift, and gain specifications make the AD542 ideal for precision op-amp applications (see adjoining column).

Although wideband performance is not often essential in precision op-amp applications, the stable internal compensation, 1MHz small-signal gain-bandwidth, 50kHz full-power bandwidth, and 3V/ μs slewing rate permit substantial gain in the dc-to-audio range without degradation of performance.

Finally, the low 1.5mA max quiescent current drain and operating supply range of $\pm 6V$ to $\pm 18V$ make the AD542 useful for applications where power drain is to be minimized, as in battery-powered remote or portable equipment and as a low-drift output buffer for CMOS DAC's.

The AD542 is recommended for any operational amplifier application requiring excellent dc performance with high input impedance at low and moderate cost. Precision instrument front-ends, requiring accurate amplification of millivolt-level signals from megohm-level source impedance, will benefit from AD542's harmonious combination of performance specifications.

*For technical data, use the reply card.

MULTIRANGE BUFFER FOR RMS VOLTMETER

The AD542, with its 80dB minimum common-mode rejection (K/L/S), will make an excellent buffer follower. However, follower circuits are not always ideal buffers for dc-to-audio rms-measuring circuitry, where gain-ranging and protection against substantial overvoltage are required. In the inverting circuit shown here, which has 1M Ω input resistance, the AD542's 50kHz full-power bandwidth and 1MHz small-signal bandwidth satisfy the crest factor and small-signal frequency response required for audio and many switching-supply-measurement requirements.

Figure 1 is a schematic of a complete gain-switched front end, using the AD536 rms-to-dc converter for ac detection. The 1M Ω input resistor limits the overload current; the single diode at the summing junction protects the AD542 from excessive positive voltage; the negative swing is limited by an internal diode, which will safely handle the overload current.

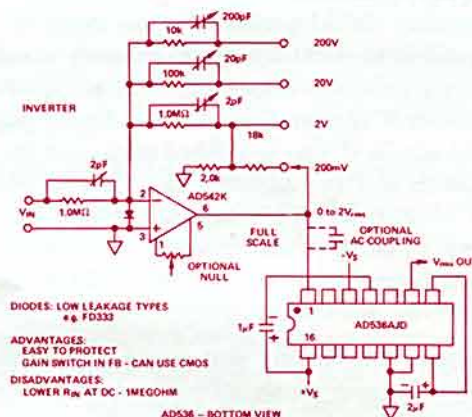

Figure 1. Inverting multi-range buffer amplifier.

The input resistor is shunted by a 2pF variable capacitance to establish a specific impedance ratio with the capacitors in the feedback path. Since the feedback path is protected from overloads, CMOS switches – often desirable in microprocessor-controlled voltmeters – may be used.

The amplifier required here must have low bias current, low voltage drift and noise, and enough bandwidth for at least the audio range, with allowance for peaks that exceed the nominal 2V rms (5.6V p-p sinewave) by at least 3x – a crest factor of 3 at full-scale. The AD542 uniquely fills this requirement. The 25pA max input current will generate only 25 μV of offset, via the 1M Ω feedback resistor. On the 200mV range, 25 μV is magnified to 250 μV – an insignificant error, compared to 2.000V full-scale at the output of the preamplifier.

The supply current for the two IC's combined is about 2mA, favoring the circuit for high-quality portable instruments, and for operation as an input circuit for an isolation amplifier, such as Models 284 or 286, which can supply a limited amount of isolated power for isolated front-end signal conditioning. ▶▶▶

BRIDGE SIGNAL-CONDITIONERS

Easy-To-Use, High-Performance, Complete, Low-Cost 2B30 & 2B31 Use Them With Strain-Gage Transducers And RTD's

by Janusz Kobel

Models 2B30 and 2B31* are compact signal-conditioning modules that provide amplification, filtering, and — in the case of the 2B31 — regulated excitation for bridge-type sensors and transducers. These modules are the first of a new generation of low-cost, high-performance, compact, sensor-interface-oriented products from Analog Devices, intended to simplify the transducer-to-computer interface and provide economical solutions to the user's signal-conditioning problems.

WHAT IS SIGNAL CONDITIONING?

The increasing demand for more-accurate industrial measurement and control systems calls for highly accurate transducers and sensors. Since transducers often do not provide directly usable high-level output signals, accurate, low-noise amplification — performed by signal-conditioning circuitry — is a critical function which largely determines the system's accuracy. If the transducer is passive — for example, an RTD or strain-gage resistance bridge — a complete signal-conditioning function involves excitation, amplification, and filtering.

Because measurements are often performed in a noisy industrial environment, with a number of sources of interference, maximum accuracy requires several modes of noise reduction. A high-quality instrumentation amplifier, with high common-mode rejection, low drift, and low noise, capable of accurate amplification of low-level differential signals riding on high, $\pm 10V$, common-mode voltages, is therefore a vital component of the signal conditioner. Another important element of the conditioner is the low-pass filter; it reduces normal-mode noise bandwidth and aliasing errors (in sampled-data systems), to further improve system signal-to-noise ratio. In addition, passive transducers, such as strain-gage bridges and RTD's, require either constant-voltage or constant-current excitation.

PERFORMANCE CHARACTERISTICS

In the past, signal conditioning required either the purchase of expensive rack-mounted equipment or a "do-it-yourself" approach. Now, the 2B30 and 2B31 offer an attractive alternative. The 2B31 is high-performance, complete signal-conditioner in a single compact 2" x 2" x 0.4" (51 x 51 x 10.2mm³) epoxy-encapsulated package. Powered by a standard $\pm 15V$

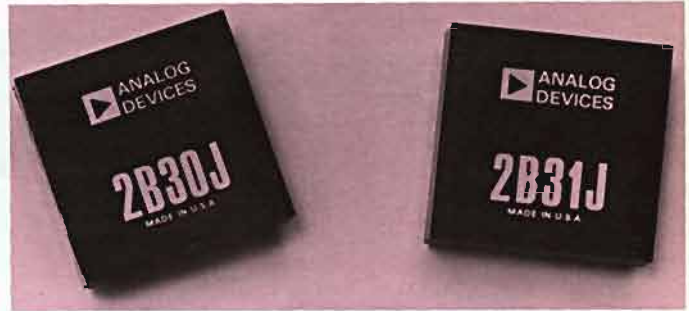

supply, the 2B31 may be directly connected to the typical resistive strain-gage or RTD bridge, to provide: a programmable voltage or current for bridge excitation, programmable gain with low drift ($0.5\mu V/^{\circ}C$ max R.T.I. @ $G = 1000V/V$, "L" version) to amplify the transducer bridge output, and a 3-pole low-pass active filter to minimize noise and aliasing errors. The 2B30 has the same amplifier and filter as the 2B31, but no excitation capability.†

Gain, low-pass cutoff frequency, output offset level, and current/voltage bridge excitation (2B31), are all adjustable, making the 2B30/31 the industry's most versatile high-accuracy transducer-interface modules. These new designs are easily and directly interfaced with a wide variety of transducers for measurement and control of pressure, temperature, stress, strain, force, and torque.

The high-input-impedance ($10^8 \Omega$) differential instrumentation amplifier has high common-mode rejection ($90dB$ min), low gain-temperature coefficient ($25ppm/^{\circ}C$ max), excellent gain linearity (to within 0.0025% max, $G = 1000$, "L" version), and low noise ($1\mu V$ p-p, $0.01Hz$ to $2Hz$). The amplifier gain is single-resistor programmable (R_{GAIN}) over a wide range (1 to $2000V/V$). The inverting buffer amplifier provides a convenient means of fine gain-trim that is independent of R_{GAIN} ; the buffer also allows the output to be offset by up to $\pm 1V$, often a necessity in strain-gage transducer or RTD interfacing applications.

The output of the buffer is applied to a 3-pole Bessel active filter with an internally set $2Hz$ corner frequency, which can be increased to as much as $5kHz$ by external resistors. The Model 2B31's high-performance bridge-excitation stage may be pin-programmed to provide from $+4V$ to $+10V$ at up to $100mA$ in a constant-voltage mode or $100\mu A$ to $10mA$, with $10V$ compliance, in the current-mode. A pair of sense terminals is provided to eliminate the effects of voltage drops on the excitation lines in the voltage mode.

Both the 2B30 and the 2B31 operate over the $-25^{\circ}C$ to $+85^{\circ}C$ ambient temperature range and are available in three versions, J/K/L, differing only in max nonlinearity and offset drift specs. Prices in 100's start at $\$34/\45 for the 2B30J/2B31J. ▶

†The 2B35 Transducer Power Supply (ac mains-to-dc), a companion module, will be announced in the Fall of 1978. Use the reply card for technical data.

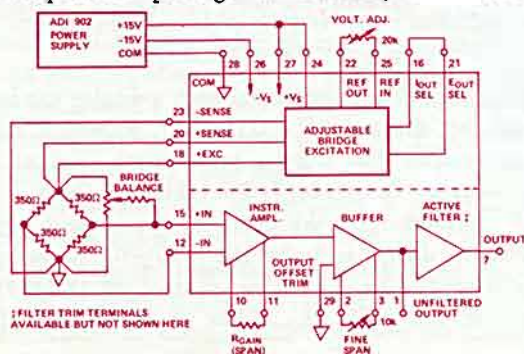

*Use the reply card for technical data.

VERSATILE DIGITAL VECTOR GENERATORS

Inputs: Analog R, Digital ϕ . Analog Outputs: $R \cos \phi$, $R \sin \phi$

by D. McDonnell

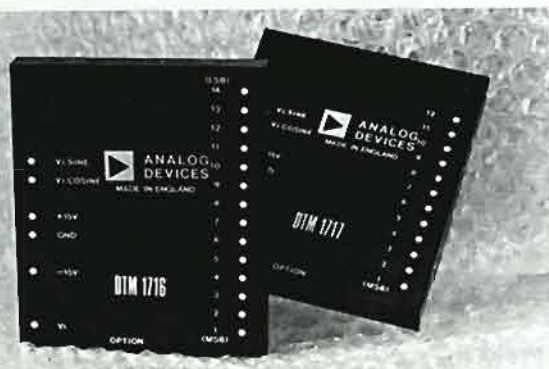

Models DTM1716 and DTM1717* are Digital Vector Generators, devices that accept 360° angular information, ϕ , in the form of a 14- or 12-bit digital word, and radius information, R, represented by analog voltage. The output consists of the pair of analog products, $R \cos \phi$ and $R \sin \phi$. Both the analog input and the analog outputs have full-scale ranges of $\pm 10V$. Figure 1 is a simplified block diagram of the devices, which differ only in resolution: the DTM1716 accepts angular information with 14-bit resolution (1LSB = 1.3 arc-minutes), and the DTM1717 accepts 12-bit angular information (1LSB = 5.3 arc-minutes).

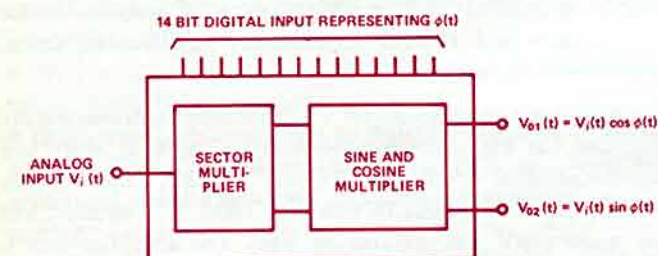

Figure 1. Diagram of DTM1716.

The devices are useful in a variety of vector operations. Several applications will be described in these pages, including low-frequency quadrature-signal generation, oscilloscope and plotter polar-plot generation, and coordinate rotation.

Scaling (analog) accuracy is typically to within 0.1% of full-scale range, with a tempco of 25ppm/ $^\circ C$ (FSR), zero-offset is 2.5mV, with 50 $\mu V/^\circ C$ drift, and nominal analog input impedance is 10k Ω . Response to an analog step settles to 0.1% in 40 μs , slewing rate is 0.5V/ μs max, with 8kHz full-power output, and analog feedthrough is <1mV at 400Hz. Response to a 90° digital step change is to within 0.1% in 40 μs , and angular error is ± 3 arc-minutes. Power-supply requirements are 50mA max at +15V and 40mA max at -15V. The standard operating temperature range is $0^\circ C$ to $70^\circ C$, with extended range versions for $-55^\circ C$ to $+105^\circ C$. Physical dimensions are 3 1/8" x 2 5/8" x 0.4" (80 x 67 x 10.2mm³) and weight is 3 oz (85 g). Prices begin at \$275 (1-9).

*For technical data, use the reply card.

ANY X,Y PLOTTER BECOMES A POLAR PLOTTER

Most plotting tables have their mechanical motions arranged by servo-controlled gantry systems, which produce control axes that are mechanically disposed at a 90° angle to one another. There are few, if any, commercially available plotting tables which are constructed with motions in polar coordinates, although the function is often available as an expensive option.

Very often, problems occur which have natural relationships in polar form. Antenna, loudspeaker, and microphone field patterns are typical examples. Acoustic echo sounders which use narrow beams also have R, ϕ forms of output.

The DTM1716 provides an extremely simple means of adapting standard X-Y plotting tables to deal with inputs in R, ϕ form (Figure 2). The plotter bias levels are set to center the pen. The DTM1716 will then provide full four-quadrant operation from an analog voltage proportional to R and a natural-binary representation of ϕ (0° to 360° , with the MSB = 180°).

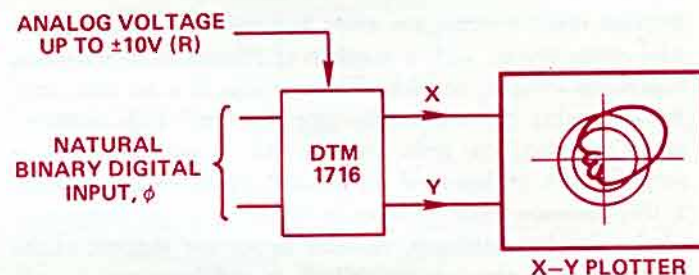

Figure 2. Using the DTM to convert an X, Y plotter for polar plotting.

Where the results of a physical measurement are being plotted in real time, it is not unusual for the digital angle to be obtained by means of a control transmitter (CX) on the rotating shaft, coupled to a synchro-to-digital converter (SDC)†

POLAR PLOTS ON A CRT - PPI DISPLAY RASTERS

In PPI (Plan-Position Indicator) radar systems, the display uses a radial time-base, with the distance from the center corresponding to range, and the angle corresponding to bearing, with North usually at the top of the display.

The radial time-base required for such a display can be simply generated by the use of a DTM1617. Figure 3 shows the required system. The angular information required for the digital input to the DTM1716 is obtained from a synchro control transmitter on the antenna; the synchro signals are converted to digital angle by the SDC1704 converter. A dc voltage is applied to the analog input of the DTM1716. This voltage will determine the radius of the display. The two

†Use the reply card for data on Analog Devices synchro-digital products.

output voltages, $V \sin \phi$ and $V \cos \phi$, are integrated from zero for a fixed time, producing a vector proportional to V at the angle, ϕ . For high-speed systems, this approach is preferable to an alternative in which sweeps of appropriate amplitude are applied to the analog input of the DTM1716.

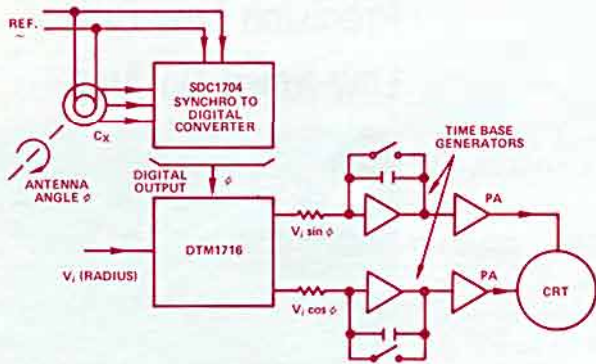

Figure 3. PPI waveform generation using the DTM1716.

LOW-FREQUENCY QUADRATURE CIRCUITRY

By the use of a pulse oscillator (clock circuit), counter, and the DTM1716, a precision quadrature oscillator with voltage-controlled amplitude can be simply constructed.

Quadrature oscillators find application in transfer-function analyzers, where the stability of amplitude is an important factor. The amplitude of the output from the DTM1716 is determined by the voltage applied to its analog input. The required stability is easily obtained, to within the resolution of the DTM.

Figures 4 and 5 show how the DTM can be used in a transfer-function analyzer and a low-frequency spectrum analyzer, both of which require quadrature signals.

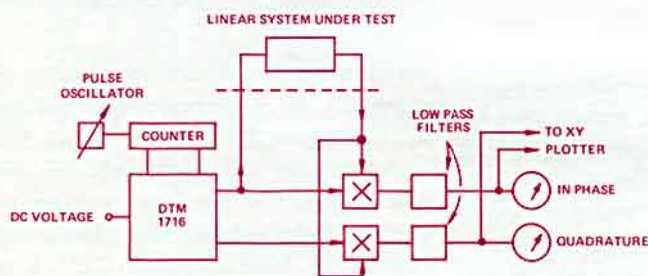
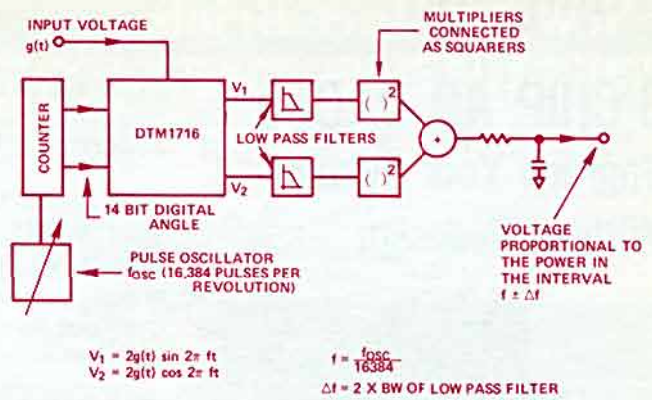

Figure 4. Block diagram of a simple transfer function analyzer.

COORDINATE ROTATION WITH THE DTM1716

In missile-control systems, radar systems, and in machine-tool control the problem often arises of obtaining the coordinates of a point relative to a new set of axes, where the coordinates of the point relative to the original axis are inputs. The two sets of coordinates may have the same origin and be shifted in angle only; or they may be displaced in origin as well as rotated apart. In either case, the solution will involve multiplications involving the trigonometric functions of the angles. Consider, for example, the simple case of the rotation of one set of axes relative to another. The axes have the same origin, and the rotation is in the X-Y plane. The method is simply



$$V_1 = 2g(t) \sin 2\pi ft$$

$$V_2 = 2g(t) \cos 2\pi ft$$

$$f = \frac{f_{osc}}{16384}$$

$$\Delta f = 2 \times \text{BW OF LOW PASS FILTER}$$

Figure 5. The use of the DTM1716 to obtain the power frequency spectrum of $g(t)$.

extended for rotations in two planes. If two straight lines originate at the same point, a single rotation in one plane is sufficient to cause the lines to coincide. However, if rotation in two planes is permitted (e.g., elevation and azimuth), then two rotations may be required to cause the lines to coincide.

For the case of 2-dimensional rotation, the equations are:

$$X_2 = X_1 \cos \phi + Y_1 \sin \phi$$

$$Y_2 = Y_1 \cos \phi - X_1 \sin \phi$$

where X_1 and Y_1 are the coordinates of the point from the original axes, ϕ is the angle through which the axes are rotated in the X-Y plane, and X_2 and Y_2 are the coordinates of the point, referred to the new axes. Figure 6 shows the connections of the DTM1716's and the summing amplifiers to carry out this operation.

In the classical text books on 3-dimensional geometry, axis rotation is usually given by sets of equations involving the Direction Cosines (the cosines of the angles between the old and the new axes; in 3 dimensions, there are 9 of them). The DTM's can be used for the formulation of these Direction Cosines from the gimbal angles (the ones usually available to the engineer).

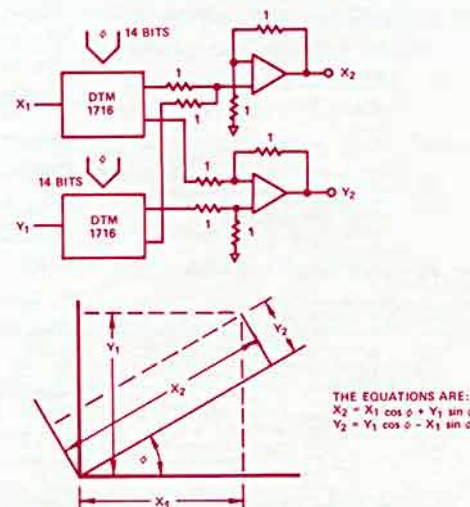

$$\text{THE EQUATIONS ARE:}$$

$$X_2 = X_1 \cos \phi + Y_1 \sin \phi$$

$$Y_2 = Y_1 \cos \phi - X_1 \sin \phi$$

Figure 6. Axis rotation in two dimensions using the DTM1716.

3-CHIP AD DAC85 Upgrade Your System Without Redesign

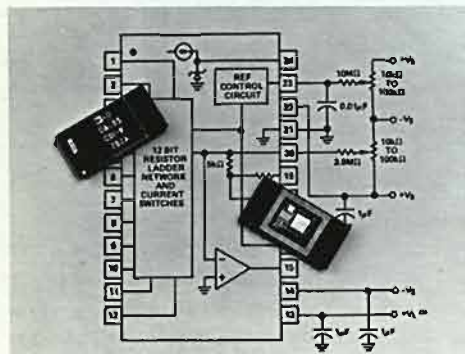

The AD DAC85* is a high-performance 12-bit digital-to-analog converter consisting of matched bipolar switches, a precision resistor network, a low-drift high-stability voltage reference, and an optional output amplifier. Input options include TTL-compatible 12-bit complementary binary (CBI) and 3-digit BCD (CCD); output options include current, "I", ($\pm 1\text{mA}$ and -2mA) and voltage "V", ($\pm 2.5\text{V}$, $\pm 5\text{V}$, $\pm 10\text{V}$, 0 to $+5\text{V}$, and 0 to $+10\text{V}$)—see block diagram below.

The AD DAC85 was designed as a superior replacement for use in existing DAC85 "sockets". It has far fewer chips (3 only) than other DAC85 devices now on the market; fewer components means inherently high reliability. Reliability is further enhanced by the AD DAC85's reduced power consumption (hence dissipation and temperature rise), which in turn fosters faster warmup and greater stability. AD DAC85's are guaranteed

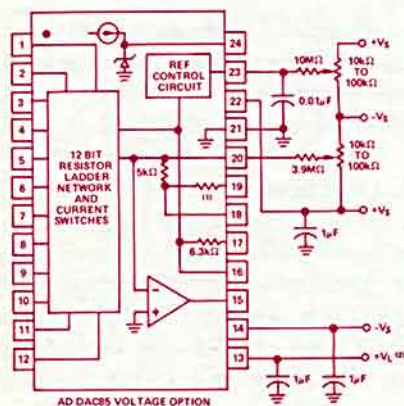

monotonic over the specified operating temperature ranges (including the -55°C to $+125^{\circ}\text{C}$ range for MIL units).

Since the AD DAC85 is compatible with other DAC85 designs, it is possible to upgrade the performance of an existing system (reliability, size, and price) by specifying the appropriate AD DAC85 for a given socket.

A low-noise, high-stability subsurface Zener diode is used to produce a reference voltage with excellent long-term stability; as an added bonus, 2.5mA of current at the reference voltage (6.3V) are available for external application.

AD DAC85's are graded according to coding (CBI and CCD), output (V or I), and temperature range (0° to 70°C , -25° to $+85^{\circ}\text{C}$, and -55° to $+125^{\circ}\text{C}$). In addition, a premium LD option is available, having max gain and offset drifts of 10 and $5\text{ppm}/^{\circ}\text{C}$, -25°C to $+85^{\circ}\text{C}$. Prices start at \$37 in 100's.

PREDICTED RELIABILITY

While the actual failure rate for a given component or equipment can only be calculated after it has been used in the field and has worn out, accurate predictions may be generated, based on the reliability history of similar components used in similar applications and similar environments.

Accordingly, reliability predictions based on MIL-HDBK-217B are widely used to predict the failure rate of new components and equipments during the design cycle. An application note is available† comparing predicted reliability of AD DAC85 and an 11-chip version currently on the market.

In summary, the advantages of the AD DAC85 over standard DAC85 devices with respect to reliability alone are that the AD DAC85

- has one-half the number of bond wires
- has 1/3 the number of internal attached components
- is in a ceramic side-braced package which has far less seal area and half the failure rate of the platform package, and
- has 1/3 to 1/5 the failure rate of standard DAC85 devices, according to MIL-HDBK-217B calculations.

FET-INPUT AD545 Precision Low-Drift Low-Noise Op Amp

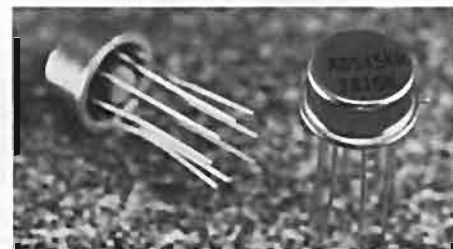

The AD545‡ is a precision FET-input IC operational amplifier fabricated using a low-leakage FET paired with a low-power op amp. It is characterized by low offset voltage—laser-trimmed to $250\mu\text{V}$ max (AD545M), low drift ($3\mu\text{V}/^{\circ}\text{C}$, max, AD545M), low bias current (1pA max, AD545K/L/M), low noise ($3\mu\text{Vp-p}$, 0.1 to 10Hz) and low cost (prices from \$5.95 in 100's — AD545J).

The AD545 is internally compensated, short-circuit protected, and free from latchup. It is supplied in a hermetically sealed TO-99 can; the metal case may be connected as a guard, which will also shield the input circuitry from external noise and supply transients, as well as reducing common-mode capacitance from 0.8pF to 0.2pF .

Bias current at 25°C is specified as the maximum at either input, fully warmed up. Low power drain (1.5mA max, 0.8mA typical) keeps temperature rise low. The combination of low input voltage and current noise means that for source impedances from $>1\text{M}\Omega$ to $10^{11}\Omega$, the Johnson noise of the source will easily dominate the noise characteristics, as the Figure shows.

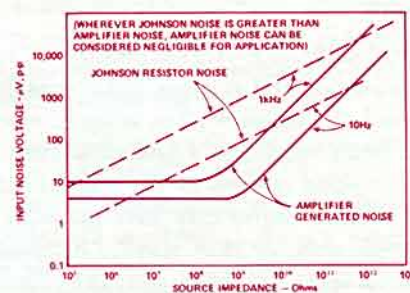

Peak-to-peak input noise voltage versus source impedance and bandwidth.

*For technical data, use the reply card.

†Use the reply card to request it.

‡For technical data use the reply card.

An Eclectic Collection of Miscellaneous Items of Timely and
Topical Interest. Further Information on Products
Mentioned Here May Be Obtained Via the Reply Card.

IN THE LAST ISSUE (Volume 12, No. 2, 1978) . . . 12-Bit IC Data-Acquisition System (AD363) . . . Monolithic Precision Multiple Voltage Reference (AD584) . . . Low-Cost Digital Temperature Indicators (AD590 with AD2040) . . . and these New-Product Briefs: Motorola-Compatible Real-Time Interfaces (RTI-1230's); Monolithic High-Accuracy Analog Divider (AD535); The AD534 Multiplier in Ceramic DIP Package; 3-Chip AD DAC80; AD537 VFC Now Available in a TO-100 Can . . . Plus two Application Notes: "IC Converter Circuit Ideas" and "Noise-Figure Test Set" . . . And two FREE new publications from Analog Devices: 600-page Data-Acquisition Products Catalog and 20-page AD537 IC Voltage-to-Frequency-Converter Application Note. Use the reply card to obtain a copy, if you don't already have one.

SHOWS . . . During the remainder of 1978, Analog Devices will be exhibiting in this major trade show in the United States: MIDCON (December 12-14, in Dallas). We are reviewing plans for next year's Show schedule, and will publish it in the next issue.

NEW LITERATURE . . . We have just published a FREE 46-page APPLICATION GUIDE TO CMOS MULTIPLYING D/A CONVERTERS, chock full of useful information, including some 26 suggested applications. Use the reply card to order your copy . . . A new data sheet on the AD2036 Scanning Digital Thermometer has been published. It will include additional standard options, such as 0.1° resolution and 1.6s and 0.8s scan intervals, plus a wider range of power-supply options: +5VDC and +12VDC

ERRATA . . . In the VFC Application Note (mentioned above), there is a minor typographical error: Page 13, Col. 1, Line 4 "Then apply a 10Hz input and trim V_{OS} for a 1.0mV output." . . . AD DAC80 Data Sheet: Page 6, Column 1, Paragraph 1, The "Z" model can indeed handle a ±5V output range quite nicely for supplies < 12V, if the ±11.4V lower limit is maintained . . . MULTIPLIER APPLICATION GUIDE, Page 35, Figure 60 (Square-root of the sum of the squares): The trim resistor is shown in series with both inputs, Y and Z, tied together, whereas on the Model 434 data sheet (Figure 10) and the Model 433 data sheet (Figure 11), the trim is in series with the Y input only. The proper connection is as shown on the data sheets, but the erroneous connection will probably work, with the pot close to the low end.

PRODUCT NOTES . . . AD1408 — Like other 1408's, the AD1408 requires a clamp diode on pin 14 if the reference voltage exceeds 5V. This point escaped our data sheet. . . AD DAC80 — Some of our units may require somewhat greater trim range than the original DAC80 design, and this is reflected by the values indicated on our data sheet: 10M Ω instead of 33M Ω (Figures 1 and 2), or 6.75k Ω instead of 3.9k Ω (Figure 7) . . . Two options of DAC1138, DAC1138J2 and DAC1138K2, are no longer available.

RETROSPECTIVE . . . In Dialogue 5-2 (1971), in an article on electrometers, we mentioned as prospective sources of precision hi-meg resistors, Victoreen, Welwyn, and MSI, based on successful experience with them. We have received a note from Semi-Films Division of National Micronetics, Inc., West Hurley, NY 12491, offering a 10⁷ Ω to 10¹² Ω range of available resistances. If you are interested in hi-meg resistors, perhaps you should investigate these as well for your applications.

GSA . . . On the price list for GSA Contract GS-00S-04748, Item Nos. 66-69b, 66-69c (synchro conversion devices), there are a few price changes and some additions. If your organization is qualified to purchase on GSA Contracts, see your Analog Devices sales engineer, or write on letterhead to the Analog Devices Sales Department, for a copy of the revised Contract (or the revisions alone).

PRICES . . . The prices for premium-grade AD581 (10V precision band-gap) references have been substantially reduced in quantity. For example, the 100-lot prices of J/K/L-S/T/U have been reduced to \$2.85/\$4.95/\$9.50-\$6.95/\$10.95/\$17.95.

TI 990 USERS: PLUG INTO THE REAL WORLD.

RTI-1240 SERIES SIX COMPLETE "PLUG-IN AND GO" ANALOG I/O SUBSYSTEMS.

Data acquisition made easy. Complete functional, mechanical and electrical compatibility with the Texas Instruments' TM990 family of powerful, 16-bit single board microcomputers. Functions are pre-wired to eliminate time-consuming set-up procedures. All you have to do is connect your analog signals and start collecting data.

Six different boards comprise the RTI-1240 Series — Combination Analog Input/Output boards (RTI-1241) with a choice of either resistor or software Programmable Gain Amplifier; Input only boards (RTI-1240) with either resistor or software PGA; and Output only boards (RTI-1242) with either four or eight Analog outputs plus eight digital logic drivers.

MEMORY MAPPED I/O SIMPLIFIES PROGRAMMING.

Memory-mapping makes a/d conversions as simple as reading data from a single memory loca-



tion; the result — reduced system software, enhanced throughput, and faster setup.

COST EFFECTIVE SOLUTIONS FOR DATA ACQUISITION PROBLEMS.

The Texas Instruments' TM990/100M 16-bit single board micro-computer coupled with the RTI-1240 Series Analog I/O Subsystems offer a complete, cost effective solution to demanding data acquisition requirements. Convenient setup, 12-bit accu-

racy, and simplified programming all add up to superior performance in the real world at a price you can live with. For example, an RTI-1240 -R analog input subsystem with 16 channels sells for \$445, complete and ready to use.

Call or write Analog Devices, Inc. P.O. Box 280, Norwood, MA 02062. Telephone: (617) 329-4700.



WAY OUT IN FRONT

AUTHORIZED ANALOG DEVICES DISTRIBUTORS FOR I/O SUBSYSTEMS.

Almac/Strom
Portland, OR
(503) 292-3534
Seattle, WA
(206) 763-2300

Arrow Electronics
Hamden, CT
(203) 248-3801
Ft. Lauderdale, FL
(305) 776-7790
Palm Beach, FL
(305) 725-1480

Doraville, GA
(404) 455-4054
Woburn, MA
(617) 933-8130
Baltimore, MD
(301) 247-5200
Ann Arbor, MI
(313) 971-8220
Bloomington, MN
(612) 888-5522
Kernersville, NC
(919) 996-2039

Manchester, NH
(603) 668-6968
Moorestown, NJ
(609) 235-1900
Saddlebrook, NJ
(201) 797-5800
Farmingdale, NY
(516) 694-6800
Fishkill, NY
(914) 896-7530
Cleveland, OH
(216) 464-2000

Kettering, OH
(513) 253-9176
Oak Creek, WI
(414) 764-6600
**Harrison
Equipment**
Houston, TX
(713) 652-4700
**Marshall
Industries**
Tempe, AZ
(602) 968-6181

Canoga Park, CA
(213) 999-5001
El Monte, CA
(213) 686-0141
Irvine, CA
(714) 556-6400
San Diego, CA
(714) 278-6350
Sunnyvale, CA
(408) 732-1100

Technico
Columbia, MD
(301) 461-2200
Roanoke, VA
(703) 563-4975
TISCO
El Segundo, CA
(213) 973-2571
San Francisco, CA
(415) 392-5700
Sunnyvale, CA
(408) 732-5555

Arlington Hts, IL
(312) 640-2964
Waltham, MA
(617) 890-0510
Clark, NJ
(201) 382-6400
Dallas, TX
(214) 238-6821
Houston, TX
(713) 776-6711